



TD-15M

CRAWLER DOZER
STD-LT-WT-LGP

EXTRA



■ **Net Horsepower**
142 kW (190 hp)

■ **Blade Capacity**
up to 5.95 m³ (7.8 yd³)

■ **Operating Weight**
20110 kg (44,335 lb) STD
20260 kg (44,665 lb) LT
20765 kg (45,779 lb) WT
21070 kg (46,451 lb) LGP

**The TD-15M Extra
is one of the best in the business
for productivity and comfort
featuring excellent design,
performance and a wide choice
of mounted equipment for four
distinct models.**



Productivity



Semi-U blades of 5.7 cu.m (7.45 cu.yd) for STD & LT track frame and 5.95 cu.m (7.8 cu.yd) for WT version, combine penetration ability of straight blade with increased capacity provided by short wings. The blades can be equipped with tilt or tilt/pitch option.



Angle blade of 3.8 cu.m (5 cu.yd) used with STD & LT track frame, is ideal for side-casting, backfilling, cutting ditches or setting a final grade by reducing amount of maneuvering required to do these jobs. 2-cylinder blade tilt is offered as an option.



Cummins QSC8.3 engine meets U.S. EPA Tier 3 and EU Stage IIIA emissions standards. The QSC advanced electronics provide enhanced engine performance with higher torque and better throttle response at every rpm. With its ideal combination of electronic controls and durable block design, this engine is ready to meet even toughest machine work conditions. Long maintenance intervals, better cold starting and quieter operation provide improved operator comfort.



6-way hydraulic angle blade of 3.8 cu.m (5 cu.yd) used with 2.03 m (80 in) gauge wide track (WT) and max. shoe width of 560 mm (22 in) is applicable for versatile operations such as finish grading, spreading material and light land clearing.



Straight blade of 3.6 cu.m (4.7 cu.yd) used with 2.16 m (85 in) gauge and 940 mm (37 in) track shoes (LGP) is designed for soft, swampy areas. This blade may be equipped with hydraulic tilt cylinder to perform efficiently landscaping operations.



Open environment

Air suspension type operator's seat is adjustable and equipped with full arm rests and 3 in retractable seat belt. The seat swivels 14° to the right for better blade and ripper viewing and enhanced controllability thus reducing operator's fatigue.



The left hand joystick controls transmission and steering drive for up and down shifting, steering Hi/Lo selection and LH/RH gradual turn. Preset travel speed selection and auto – downshift provide comfortable operation and high productivity without manual downshifting.

The comfortable cab with air recirculation system is sealed, sound suppressed and separated from the engine compartment. Demountable 6-sided cab with deluxe interior provides superior all-around visibility and operator's comfort. Two doors with side sliding windows and large window area provide good blade and ripper viewing for precise control of mounted equipment.

Operator's Environment



Various blade control levers are used for distinct work equipment specifications (tilt only, tilt/pitch or 6-way blade). Pilot operated hydraulic controls are offered as an option. The right hand ergonomical lever controls raise and lower of the ripper.



Optional sweeps and screening package are designed to provide operator protection in various types of forestry applications.



Specification

ENGINE

| | |
|------------------------------------|---|
| * Make and Model | Cummins QSC 8.3 |
| Type | In-line, 6-cylinder |
| Aspiration | Turbocharged and CAC |
| Fuel system | HPCR Electronic |
| Gross Horsepower, SAE J1995 | 153 kW (205 hp) |
| Net Horsepower, SAE J1349/ISO 9249 | 142 kW (190 hp) |
| Rated rpm | 1950 rpm |
| Max. torque @ 1450 rpm | 1010 Nm (745 ft-lb) |
| Displacement | 8.3 l (505 in ³) |
| Bore and Stroke | 114 x 135 mm (4.49" x 5.32") |
| Air cleaner | dry type with exhaust aspirated primary and safety elements and service indicator |

*Meets EU Stage IIIA and EPA Tier 3 emission regulations

TRANSMISSION & TORQUE CONVERTER

Modular, countershaft type power shift, electro-hydraulic control. Preset travel speed selection and auto-downshift. Single stage 370 mm (14.6") torque converter with a 2.6:1 stall ratio drives to transmission through a double universal joint.

TRAVEL SPEEDS

| Gear | Range | Forward | | Reverse | |
|------|-------|---------|-------|---------|-------|
| | | km/h | (mph) | km/h | (mph) |
| 1 st | Low | 2.7 | (1.7) | 3.2 | (2.0) |
| | High | 3.6 | (2.2) | 4.3 | (2.7) |
| 2 nd | Low | 4.9 | (3.0) | 5.7 | (3.5) |
| | High | 6.5 | (4.0) | 7.6 | (4.7) |
| 3 rd | Low | 7.7 | (4.8) | 9.0 | (5.6) |
| | High | 10.2 | (6.3) | 11.9 | (7.4) |

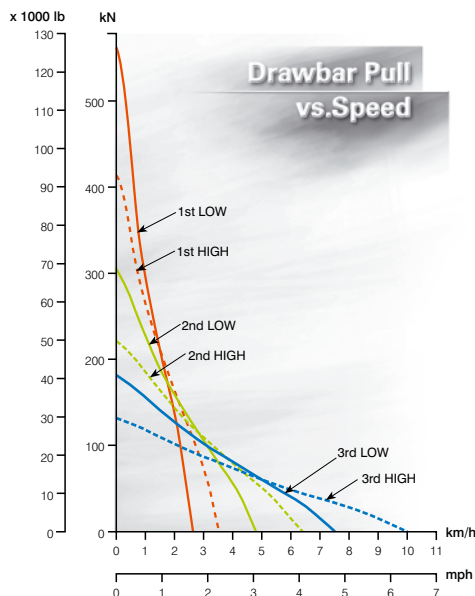

STEERING & BRAKING

Two speed geared steering module provides gradual turns while maintaining full power to both tracks plus conventional clutch-brake performance for tight or pivot turns. This type of steering system offers superior traction in all types of operations and terrain. Coupled to 3-speed transmission, the 2-speed steering provides 6 speeds forward and 6 reverse. The left hand joystick controls transmission and steering drive for up and down shifting, steering, Hi/Lo selection and LH/RH gradual geared turn. Foot pedal applies both brakes for parking and downhill control. Brakes are spring applied and hydraulically released.

FINAL DRIVES

Double-reduction module provides desired gear reduction at the sprocket. Ring-type sprocket distributes wear evenly over track bushings, letting every tooth ride free one-half of the time to reduce wear. Final drives or sprockets are replaceable without removing track frames.

TRACK FRAME

All-welded heavy box section track frame is kept in alignment with track frame guides providing true vertical oscillation. Track rollers, each side STD (LT, WT, LGP) 6 (8)
 Top idlers, each side 2
 Front idlers (drum type) 1
 All rollers and idlers lifespan lubricated
 Oscillation at center of front idler (STD) 293 mm (11.52")
 Oscillation at center of front idler (LT, WT, LGP) 353 mm (13.9")

TRACKS

Lubricated Track System (LTS) virtually eliminates internal pin and bushing wear through use of a patented seal assembly. The split master link reduces chain removal and installation time.

| | STD | LT | WT | LGP |
|------------------------------------|---|---|---|---|
| Track shoe width, standard | 508 mm (20") | 508 mm (20") | 762 mm (30") | 940 mm (37") |
| Track shoes, each side | 39 | 43 | 43 | 43 |
| Ground contact area | 2.7 m ² (4,160 in ²) | 3.1 m ² (4,800 in ²) | 4.6 m ² (7,200 in ²) | 5.7 m ² (8,880 in ²) |
| Ground pressure (w/std. equipment) | 75.4 kPa (10.9 psi) | 65.8 kPa (9.5 psi) | 44.9 kPa (6.5 psi) | 36.9 kPa (5.4 psi) |
| Height of grouser | 64 mm (2.52") | | | |
| Ground clearance | 445 mm (17.5") | | | |

REFILL CAPACITIES

| | Liter | (US gal) |
|----------------------------------|-------|----------|
| Fuel tank | 388 | (102.5) |
| Cooling system | 50 | (13.2) |
| Crankcase w/filters | 23 | (6.1) |
| Transmission system | 153 | (40.4) |
| Differential & final drive, each | 40 | (10.6) |
| Hydraulic reservoir | 60 | (16) |

OPERATING WEIGHT

Includes standard equipment and full fuel.

| | STD | LT | WT | LGP |
|---------------|----------------------|----------------------|----------------------|----------------------|
| Type of blade | Semi-U | Semi-U | Semi-U | Straight |
| Canopy ROPS | 20110 kg (44,335 lb) | 20260 kg (44,665 lb) | 20765 kg (45,779 lb) | 21070 kg (46,451 lb) |
| Cab ROPS | 20660 kg (45,547 lb) | 20810 kg (45,878 lb) | 21315 kg (46,991 lb) | 21620 kg (47,663 lb) |

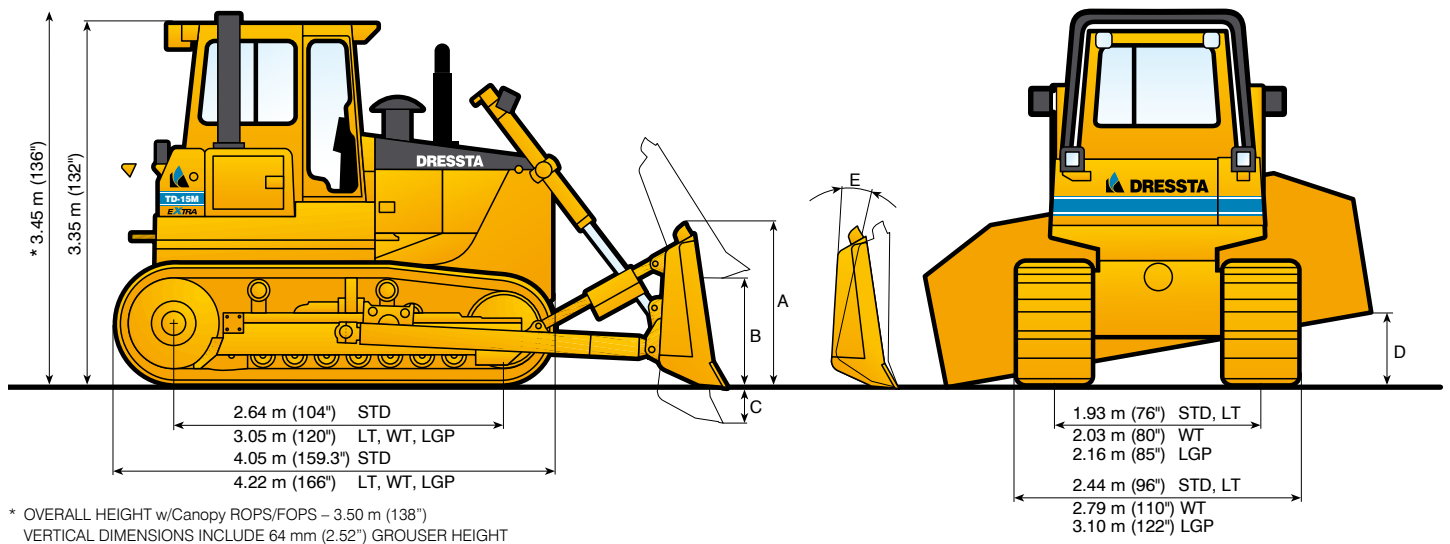

OVERALL DIMENSIONS WITH EQUIPMENT

| | UNDRRCARRIAGE | BLADE SELECTION | | | | |
|---|---------------|-----------------|-----------------|-----------------|----------------|------------------|
| | | SEMI-U | ANGLE | 6-WAY | SEMI-U | STRAIGHT |
| Length with blade, and drawbar | STD | 5.23 m (17'2") | 5.39 m (17'8") | — | — | — |
| | LT | 5.67 m (18'7") | 5.83 m (19'2") | — | — | — |
| | WT | — | — | 5.87 m (19'3") | 5.67 m (18'7") | — |
| | LGP | — | — | — | — | 5.52 m (18'1") |
| Length with blade, and multi-shank ripper | STD | 6.48 m (21'3") | 6.55 m (21'6") | — | — | — |
| | LT | 6.91 m (22'8") | 6.99 m (22'11") | — | — | — |
| | WT | — | — | 7.03 m (23'1") | 6.94 m (22'9") | — |
| Length with blade and single-shank ripper | STD | 6.25 m (20'6") | 6.40 m (21') | — | — | — |
| | LT | 6.76 m (22'2") | 6.84 m (22'5") | — | — | — |
| | WT | — | — | 6.88 m (22'7") | 6.79 m (22'3") | — |
| Width, blade angled | STD< | — | 3.75 m (12'4") | — | — | — |
| | WT | — | — | 3.33 m (10'11") | — | — |
| Width over trunnions | STD< | 2.81 m (9'3") | 2.81 m (9'3") | — | — | — |
| | WT | — | — | — | 2.91 m (9'7") | — |
| | LGP | — | — | — | — | 3.34 m (10' 11") |
| Width over „C“ frame | STD< | — | 3.82 m (12'6") | — | — | — |

BLADE SPECIFICATIONS

| UNDERCARRIAGE | | STD< | STD< | WT | WT | LGP |
|--|---|---|---|-------------------------------|-------------------------------|-------------------------------|
| | | SEMI-U | ANGLE | 6-WAY | SEMI-U | STRAIGHT |
| Track shoes | | 20"/22"/24"/26" | 20"/22"/24"/26" | 20" or 22" | 30"/26"/24"/22"/20" | 37" |
| Blade capacity, SAE J1265 | | 5.7 m³ (7.45 yd³) | 3.8 m³ (5 yd³) | 3.8 m³ (5 yd³) | 5.95 m³ (7.8 yd³) | 3.6 m³ (4.7 yd³) |
| Blade dimensions: – with over end bits – height | A | 3.44 m (135") 1.46 m (58") | 4.13 m (163") 1.12 m (44") | 3.68 m (145") 1.20 m (47") | 3.59 m (141") 1.46 m (58") | 3.86 m (152") 1.10 m (43") |
| | B | STD 1104 mm (43.5") LT 1102 mm (43.4") | STD 1102 mm (43.4") LT 1119 mm (44") | 1280 mm (50.4") | 1102 mm (43.4") | 1240 mm (49") |
| Max. drop below ground level | C | 463 mm (18.2") | STD 552 mm (21.7") LT 542 mm (21.3") | 715 mm (28.1") | 463 mm (18.2") | 455 mm (18") |
| Max. tilt adjustment | D | 724 mm (28.5") | 385 mm (15.2") | 470 mm (18.5") | 782 mm (30.8") | 698 mm (27.5") |
| Blade angle, either side | | — | 25° | 23.5° | — | — |
| Max. pitch adjustment | E | 9° | — | 8° | 9° | 9° |
| Weight of blade equipment | | 2670 kg (5,886 lb) | 2700 kg (5,952 lb) | 2575 kg (5,677 lb) | 2760 kg (6,085 lb) | 2740 kg (6,040 lb) |

RIPPER SPECIFICATION

| RIPPER SELECTION | MULTI-SHANK | SINGLE-SHANK |
|---|----------------------------------|------------------------------|
| Tool Beam | | |
| Overall width | 2230 mm (88") | 1100 mm (43") |
| Cross section (height x width) | 229 x 254 mm (9" x 10") | 269 x 284 mm (10.6" x 11.2") |
| Ground clearance under tool beam: – ripper raised – ripper lowered | 1023 mm (40.3") 108 mm (4.3") | 995 mm (39") 80 mm (3") |
| | | |
| Shanks | | |
| Number of shanks per ripper, max. | 3 | 1 |
| Spacing center to center | 1015 mm (40") | — |
| Penetration, max. | 600 mm (24") | 713 mm (28") |
| Ground clearance, max. raised | 455 mm (17.9") | 485 mm (19") |
| Shank positions (vertical) | 2 | 2 |
| Weight | | |
| Complete, including one shank | 1554.5 kg (3,427 lb) | 1546 kg (3,408 lb) |
| Each additional shank | 94.5 kg (208 lb) | — |
| Penetration Force | 64 kN (14,387 lb) | 71.04 kN (15,970 lb) |
| Pryout Force | 268.7 kN (60,404 lb) | 390.9 kN (87,874 lb) |

TD-15M

CRAWLER DOZER

STD-LT-WT-LGP



HYDRAULIC CONTROL SYSTEM

| | | | |
|--|----------------------|-----------------------------|---------------------------------------|
| Pump, tandem gear, driven from torque converter. | | Cylinders, bore and stroke: | |
| Output @ rated engine rpm..... | 173 l/min (46 gpm) | lift (STD) | 101.6 x 1233.5 mm (4" x 48.6") |
| Relief valve setting..... | 17.2 MPa (2,500 psi) | lift (LT, WT, LGP) | 101.6 x 1095 mm (4" x 43.1") |
| | | tilt | 139.7 x 147 mm (5.5" x 5.8") |
| | | tilt/pitch | 139.7/152.4 x 147 mm (5.5"/6" x 5.8") |

STANDARD EQUIPMENT

- Air cleaner, dry type with exhaust aspirated primary and safety elements and service indicator
- Alarm, back-up
- Alternator, 50 A
- Antifreeze, -37°C (-34°F)
- Batteries, (2) 12 V, 815 CCA, maintenance free
- Brakes, foot, spring applied, hydraulically released
- Canopy, 2 post ROPS/FOPS (SAE J1040, J231)
- Coolant filter conditioner
- Cooling module; includes radiator, transmission oil cooler, charge air cooler; isolation mounted
- Decelerator – right foot pedal and brake – center foot pedal
- Diagnostic centers for power train and equipment hydraulic pressures
- Ecological drains for engine oil, radiator coolant and hydraulic oil
- Engine hood, solid, sloped
- Engine side doors, hinged, perforated type
- Exhaust pipe extension with elbow
- Fan, blower
- Filters engine oil, full flow and by-pass with replaceable "spin-on" elements
- Filters, power train
- Final drive seal guard
- Fuel strainer
- Guards: crankcase, hinged, with front pull hook, transmission, fan, radiator and sprocket rock and dirt deflector
- Hitch, retrieval
- Horn, electric
- Hydraulic controls, linkage, 2-spool valve, 1 lever (lift/tilt)
- Instruments:
 - Gauges: fuel level, engine coolant temp., engine oil pressure, torque converter oil temp., voltmeter, hourmeter, brake lock
 - Warning lights: air cleaner filter, transmission oil filter, hydraulic oil filter, transmission/clutch oil low pressure
- Audible & visual warning system: low engine coolant level, low engine oil pressure
- Lights with guards, 2F – lift cylinders, 2R – fuel tank mounted
- Muffler, under engine hood, insulated
- Radiator guard door, hinged, louvered
- Rear access platform
- Receptacle, starting/charging
- Seat belt (SAE J386) – 3" wide, retractable
- Seat, deluxe, air suspension type, vinyl cover, adjustable with arm rests, swivel 14° to right
- Starting aid – air grid heater
- Starting, 24 V
- Steering, planetary type, 2 speed, left hand single lever control (joystick)
- Tools compartment
- Torque converter, single stage
- Transmission power shift, 3 speeds forward, 3 reverse, preset travel speed selection and auto-downshift
- Water separator, fuel system
- UNDERCARRIAGE
 - Track frames, oscillating type, lifespan lubricated rollers and idlers
 - Track adjusters, hydraulic
 - Track chain end guides, integral
 - STANDARD (STD)
 - Track chain, sealed and lubricated (LTS) with split master link, 39 links
 - Track frame, 6 roller, 1930 mm (76") gauge
 - Track shoes, 508 mm (20") severe service
 - LONG TRACK (LT)
 - Track chain, sealed and lubricated (LTS) with split master link, 43 links
 - Track frame, 8 roller, 1930 mm (76") gauge
 - Track shoes, 508 mm (20") severe service
 - Track chain center guides
 - WIDE TRACK (WT)
 - Track chain, sealed and lubricated (LTS) with split master link, 43 links
 - Track frame, 8 roller, 2030 mm (80") gauge
 - Track shoes, 762 mm (30") severe service
 - Track chain center guides
 - LOW GROUND PRESSURE (LGP)
 - Track chain, sealed and lubricated (LTS) with split master link, 43 links
 - Track frame, 8 roller, 2160 mm (85") gauge
 - Track shoes, 940 mm (37") extreme clipped corner with bolt holes for 3 rd rail track
 - Track chain center guides

OPTIONAL ATTACHMENTS

- AM/FM CD radio
- Batteries, cold start (2) 12 V, 960 CCA
- Blade Equipment (STD & LT):
 - Semi-U Dozer, 5.7 cu. m (7.45 cu. yd)
 - Hydraulic tilt
 - Hydraulic tilt/pitch
 - Angle Dozer (manual angle), 3.8 cu. m (5 cu. yd)
 - Hydraulic tilt
- Blade Equipment (WT):
 - Semi-U Dozer, 5.95 cu. m (7.8 cu. yd)
 - Hydraulic tilt
 - Hydraulic tilt/pitch
 - Angle Dozer (6-way), 3.8 cu. m (5 cu. yd)
 - full hydraulic, inside arm with hydraulic tilt, angle and manual pitch
- Blade Equipment (LGP):
 - Straight Dozer, 3.6 cu. m (4.7 cu. yd)
 - Hydraulic tilt
- Cab and ROPS Equipment:
 - Air conditioner/heater/pressurizer/defroster, underseat mounted; A/C condenser behind roof
 - Air recirculation system with MSHA filters
 - Cab w/sound suppression, 4 wipers w/washers, inside mirror, dome light, tinted safety glass and air recirculation system
 - Heater /pressurizer/ defroster
 - ROPS for cab or forestry attachment
 - Sun visor in cab
 - Sweeps, forestry, front and rear
 - Screen rear (includes deduct for standard rear access platform)
 - Seat, air suspension, fabric cover (for use w/cab)
- Drawbar, fixed
- Engine enclosures: perforated hood and perforated side doors
- Exhaust pipe extension w/guard, for sweeps
- Guards:
 - Crankcase, severe service w/front pull hook
 - Final drive, rock (STD, LT, WT)
 - Tank guard, bolted (includes deduct for rear access platform)
 - Track roller, full length
 - Transmission, severe service
- Hydraulic controls, linkage:
 - 2-spool valve, 1 lever (for use with 6-way)
 - 3-spool valve (3 rd section plugged), 1 lever (for use with tilt-pitch)
 - 3-spool valve, 2 lever (for use w/ripper and tilt/tilt-pitch or 6-way)
- Hydraulic controls, pilot operated:
 - 3-spool valve (3 rd section plugged), 1 lever (for use with 6-way or tilt/tilt-pitch)
 - 3-spool valve, 2 lever (for use w/ripper and tilt/tilt-pitch or 6-way)
- Inspection lamp, 24 V, portable with 6 m (20') cable
- Instrument panel guard (for use w/Canopy ROPS/FOPS)
- Lights for Canopy ROPS/FOPS, 2F–2R
- Lights for cab, 2F–2R
- Lights for cab and sweeps, 2F–2R
- Lights, 2F, ROPS mounted, for use with cab, (not for use with sweeps)
- Mirrors, 2 pcs. exterior (for use w/cab)
- Ripper, multi-shank, max. 3 shanks
- Ripper, single-shank
- Screening pkg; cab for screens installation must be ordered:
 - Screens for cab windows (front, rear, side and doors)
 - Screens for tractor and cab lights
- Starting/charging receptacle plug assembly
- Third rail track system (LGP)
- Tools in metal box
- Track shoes, set of 78, severe service (STD) 560 mm (22"), 610 mm (24"), 660 mm (26")
- Track shoes, set of 86, severe service (LT) 560 mm (22"), 610 mm (24"), 660 mm (26")
- Track shoes, set of 86, severe service (WT) 508 mm (20"), 560 mm (22"), 610 mm (24"), 660 mm (26"), not for use with Angle Dozer (6-way)
- Vandalism protection

Specifications subject to change without notice. Illustrations and pictures may include optional attachments and accessories and may not include all standard equipment.

DRESSTA Co.Ltd.

Kwiatkowskiego 1, 37-450 Stalowa Wola, P O L A N D
 tel. 48 15 813 5252, 813 4556 fax: 48 15 844 4714
www.dresssta.com.pl