

# 924G

## Wheel Loader



### Standard and High Lift Arrangements



#### Engine

Model	Cat <sup>®</sup> 3056E DIT ATAAC	
Flywheel Power	90.1 kW	121 hp
Max. Flywheel Power	98 kW	132 hp

#### Buckets

Bucket Capacities	1.7 m <sup>3</sup> - 5.0 m <sup>3</sup>	2.2 yd <sup>3</sup> - 6.5 yd <sup>3</sup>
-------------------	---	---

#### Weights

Maximum Weight	10 328 kg	22,769 lb
----------------	-----------	-----------

# 924G Wheel Loader

*Offering world class performance, value and reliability.*

---

## Caterpillar® Power Train

✓ The 924G uses a Caterpillar power train for reliable, long life. The Caterpillar 3056E DIT ATAAC six-cylinder engine with Cat power shift transmission are performance-matched to the torque converter and axles for smoother performance and greater operator comfort. **pg. 4**

---

## Operator Station

✓ The 924G operator station is ergonomically designed to create a comfortable work area. Easy-to-use machine controls and a new gauge console reduce operator fatigue and increase efficiency and productivity. **pg. 6**

---

## VersaLink™ Loader Linkage

Loader linkage gives the 924G unsurpassed visibility, versatility and stability. The single piece boom-style lift arm design offers exceptional strength, rigidity and visibility. A high lift version is available for high-dump or long reach requirements. **pg. 8**

---

## Owning & Operating Costs

Extended service intervals, an advanced electronic warning system, lower fuel consumption and faster cycle times save you time and money. **pg. 12**

---

## Environmentally Responsible Design

✓ Quiet operation, low engine emissions, less fluid disposal and clean, easy servicing help you meet worldwide regulations and protect the environment. **pg. 13**

---

## Complete Customer Support

Caterpillar dealers offer unmatched customer support, with excellent warranty programs and fast parts availability, resulting in maximum uptime and minimum repair costs. **pg. 14**

*The 924G is one of the most versatile wheel loaders in the world. Size, power, performance and interchangeability of work tools make this machine ideal for a wide range of jobs.*





### Work Tools

A wide range of Caterpillar Work Tools are available to meet the needs of your jobsite applications. The machine's quick coupler system allows the operator to quickly change from one high performance work tool to another without leaving the cab. **pg. 9**

### Hydraulic System

Modular hydraulic system offers fast loading cycles, easy reconfiguration and exceptional ride control. **pg. 10**

### Serviceability

Perform daily maintenance with easy ground-level access to all major service points. Gull-wing doors provide excellent engine access and a swing-out fan simplifies radiator service. **pg. 11**



## Caterpillar Power Train

*Rugged, dependable Cat components deliver maximum rimpull to the ground and full power to the loader hydraulics.*



**Caterpillar Engine.** The six-cylinder 3056E Direct Injection Turbocharged (DIT) engine with Air-to-Air After Cooler (ATAAC) has a proven reputation for reliability, durability and performance. Fuel injection is electronically controlled for precise timing.

**Torque Rise.** The engine features a 48% torque rise for increased power during heavy-duty use.

**Emission Standards.** The 3056E DIT ATAAC engine meets worldwide emissions standards.

**Cylinders.** Low cylinder pressure rise and low peak pressure provide outstanding reliability and durability.

**Cooling System.** Engine and cooling system are in separate compartments for clean, quiet operation and easy service.

**Air-to-Air After Cooling.** Air-to-air after cooling reduces engine emissions.

**Electronic Control Module.** The Caterpillar engine control module not only controls the timing needs of the engine but also monitors critical systems to maintain optimum performance and provide engine protection.

**Service Intervals.** The recommended engine oil change requirement is every 500 hours of operation.

**Axles.** Heavy-duty design features strong gears and bearings for durable performance. Oscillating rear axle helps assure four-wheel ground contact for optimum traction and stability.

**Brakes.** Oil-disc brakes are adjustment-free and fully enclosed.

**Optional Heavy-Duty Brakes.** Optional heavy-duty brakes provide additional brake discs and axle oil cooler for severe applications.

**Duo-Cone® Seals.** Duo-Cone Seals keep oil in and contaminants out.

**Limited Slip Differentials.** Optional front and rear Limited Slip Differentials provide improved traction in poor or uneven underfoot conditions.

**Transmission.** Rugged, field-proven Caterpillar 4F/3R transmission uses heavy-duty components for durable and reliable operation. High-energy friction materials allow for better heat tolerance while thick reaction plates allow for better heat dissipation. The transmission is also designed for easy service and rebuild.

**Electronic Clutch Pressure Control.** The Electronic Clutch Pressure Control (ECPC) manages shift torque providing exceptional smoothness.

**Gears.** High-contact ratio spur gears are precision ground and heat treated for quiet, durable operation.

**Shifting Options.** Operator can choose manual shift or two autoshift modes (full throttle or variable shift control). Full throttle selection provides maximum acceleration while variable selection increases fuel economy and improves operator comfort.



# Operator Station

*Ergonomic design emphasizes comfort, visibility and easy operation.*



**Instrument Panel.** Redesigned instrument panel is conveniently located with easy-to-read gauges and expanded warning/indicator and diagnostic functions.

**Electronic Engine Speed Control.** A specific engine RPM can be set and maintained with a switch in the cab.

**Steering System.** The load-sensing, closed-center steering system with flow amplification matches steering response to a wide variety of applications. The adjustable steering console lifts easily out of the way. Dual suspended brake pedals function as a brake and a transmission neutralizer so the operator can maintain high engine RPM for full hydraulic flow and fast cycle times.

**Cab.** The ergonomic cab provides a comfortable work environment with large windows, spacious interior room, generous storage areas and low interior sound levels.

**Access/Egress.** Access/egress is through a two-door design. Both doors open fully and lock flush against the cab. Steps leading up to the cab are wide and angled out for secure footing.

**Windows.** Large windows improve visibility in all directions. The rear window features a standard electric defroster. Sliding glass is available as an option on the doors.

**Visibility.** Visibility to critical areas such as the bucket have been optimized. Lift arm spacing is wide and linkage geometry maximizes visibility throughout the production cycle.



**Low Effort Operation.** Hydraulic joystick controls provide ease of lift and tilt functions. A single joystick is standard. An integrated directional control switch on the joystick provides easy operation and enhanced productivity. A two lever control is optional.

**Seat.** The standard seat is available in cloth or vinyl with fully adjustable fore/aft position, seatback angle, bottom cushion height, armrest angle and suspension stiffness. Other seat options include:

- Cat Contour Seat, fabric, with adjustable backrest and lumbar support.
- Cat Contour Seat, fabric, electrically adjustable with air suspension.

**Seat Belt.** All seats include a comfortable 75 mm (3 inch) wide retractable seat belt.



**Storage.** Generous storage space includes a lockable compartment, coat hook and special molded compartments designed to hold a lunchbox/cooler, cup or can. A tool box is also provided.

**Customize the Cab.** The cab can be customized with:

- 12V converter for powering electronics such as cellular phones, two-way radios and music systems

- Radio installation package
- Sun visor for windshield
- Roll-down sun screen for rear window
- External mirror package
- Auxiliary lighting packages



# VersaLink™ Loader Linkage

*Linkage design offers unparalleled versatility without compromise to performance.*



**Linkage Design.** Versatility is the key benefit of the VersaLink loader linkage. The 924G can be configured in many ways:

- with a Quick Coupler, work tool changes are quick and easy. In this configuration, the 924G offers the versatility of an integrated toolcarrier and the performance of a wheel loader;

- equipped with pin-on tools, like a bucket, the 924G becomes a dedicated wheel loader, with exceptional breakout force, tipping load and dump height;
- equipped with the High Lift VersaLink loader linkage option, the 924G is ideal for special applications that require more reach and lift height.

**Reconfiguration.** The VersaLink loader linkage can be reconfigured from pin-on to Quick Coupler or from standard linkage to high lift linkage with a minimum of new parts required.

**Outstanding Performance.** The VersaLink loader linkage is designed for exceptional loader performance in a wide range of applications, offering:

- increased breakout force to shorten cycle times and increase bucket fill factors;
- higher dump clearance for working in “high target” situations that ordinary loaders cannot;
- more dig depth for better excavation performance, even when equipped with larger 20.5 x 25 tires;
- greater rackback angle for improved material retention, resulting in higher productivity;
- greater dozing angle for improved control of material when fine grading.

**Visibility.** The VersaLink loader linkage’s sleek design gives unobstructed visibility to critical areas such as the bucket corners and fork tips for more productive material and pallet handling.

**Parallel Lift.** Parallel lift simplifies working with palletized or stacked material. Operators can concentrate on material placement while the load automatically remains parallel throughout the lift range. And, like an integrated toolcarrier, the 924G can easily manipulate loads.



# Work Tools

*Increase your productivity by performing a variety of jobs with one machine.*

**Versatility.** With a variety of work tools offered by Caterpillar, the 924G is ideal for a wide range of applications.

**Quick Coupler.** Work tools can be changed quickly and easily with the machine's integral quick coupler system. A switch in the operator compartment activates a hydraulic cylinder for positive tool engagement or disengagement.

**Buckets.** With exceptional rimpull and high breakout and lift forces, the 924G demonstrates strong performance as a bucket loading machine. A wide range of Caterpillar buckets are available including:

- general purpose
- penetration
- light material
- multi purpose
- side dump
- high dump
- material handling

**Material Handling.** Exceptional visibility and heavy-lift capabilities enable you to work quickly and efficiently with the 924G as a material handler. A wide range of tools are available such as:

- pallet forks
- lumber and log forks
- material handling arm
- tire loaders
- specialty clamps



**Special Applications.** Some of the numerous specialty tools available include:

- dozer blades
- snow plows
- hydraulic brooms
- asphalt cutter
- loader rakes

**Auxiliary Hydraulics.** Optional 3rd and 4th function hydraulics are available for use with work tools that require hydraulic power, such as rotary brooms, augers, high dump and side dump buckets.

# Hydraulic System

*Modular system provides improved efficiency and greater control.*



**Precise Control.** Designed by Caterpillar, the modular hydraulic system provides low effort operation and superior control.

**Performance.** Fast loader cycle times result in greater productivity. The hydraulic system is matched to the power train for outstanding performance.

**Load-Sensing Implement Hydraulics.** Load-sensing implement hydraulics provide exceptional second gear hydraulic-to-rimpull match for better material handling.

**Joystick Control.** Low effort, joystick implement control improves efficiency with simultaneous lift and tilt functions.

**Tilt Cylinder.** A large tilt cylinder delivers exceptional backdrag performance.

**Hoses.** Caterpillar XT™ hoses and couplings provide rugged, reliable performance with significantly reduced risk of leaks and blown lines.

**Modular Hydraulic Control Valves.** Modular hydraulic control valves add a new dimension of versatility that greatly simplifies and lowers overall cost of reconfiguring the machine for additional functions.

**Two-Section Control Valve.** The 924G comes equipped with a two-section control valve for lift and tilt functions. Up to two additional valve sections can be stacked on the existing ones.

**Ground Level Access.** The control valves feature convenient ground level access for easy modifications to the system.

**Pumps.** Separate steering and implement pumps improve machine response.

**Load-Sensing Steering.** Load-sensing steering provides low effort operator control, making more power available for rimpull, breakout and lift forces.

**Pressure Taps.** Standard pressure taps allow quick diagnosis of the entire hydraulic system.

**Optional Ride Control System.** The improved Ride Control System provides a comfortable ride at all speeds and improved hard bank digging. Three modes are available: auto, on and off.



## Serviceability

*Improved access and fewer maintenance requirements add up to unparalleled ease of service.*

**Easy Access.** Gull-wing engine enclosure doors with gas struts lift for exceptional access to filters and service points. Radiator and oil coolers are easily accessible for cleaning.

**Simplified Routine Service.** All service points are accessible from the ground level. Easily check radiator coolant, hydraulic oil and transmission oil levels with sight gauges.

**Swing-out Cooling Fan.** A swing-out cooling fan allows quick, easy cleaning and service of the radiator. The fan is hydraulically driven and separate from the engine compartment for exceptional low noise operation.

**Optional Reversing Fan.** Optional reversing capability of the fan cleans screens without interrupting machine operation.

**S•O•S<sup>SM</sup> Ports.** Scheduled Oil Sampling ports are factory installed for improved access to engine, transmission and hydraulic oils. S•O•S ports make oil sampling quicker, cleaner and provide the best oil sample for analysis.

**Oil Filters.** Spin-on filters for engine oil, transmission oil and hydraulic oil are vertically mounted for easier servicing.

**Self-Diagnostics.** Self-diagnostic transmission and data link allows quick and easy troubleshooting by service personnel. Service codes are easily accessed through the gauge console.



### Extended Life Coolant/Antifreeze.

Cat Extended Life Coolant/Antifreeze allows extended operation (up to 6,000 hours) between changes.

**Other Service Features.** Other service features include:

- Maintenance-free driveshaft
- Stationary radiator and coolant hoses

- Standard hydraulic oil cooler
- Adjustment-free brakes
- Adjustment-free engine fuel system
- Grouped grease fittings
- Positive torque hose clamps
- Braided, color coded and numbered wiring



## Owning & Operating Costs

*Cost saving features help improve your bottom line.*



**Low Fuel Consumption.** The 3056E DIT ATAAC engine features low fuel consumption for more economical operation.

**Increased Power, Faster Cycle Times.** Higher horsepower and increased torque rise results in more power and faster cycle times, allowing the operator to get more work done in a day.

**Extended Service Intervals.** Service intervals have been extended to reduce machine service time and increase machine availability:

- 4,000 hour hydraulic oil change (S•O•S sampling required)
- 1,000 hour hydraulic filter change
- 500 hour engine oil change

**Smoother Transmission for Increased Productivity.** A smoother shifting transmission provides a more comfortable work environment, allowing the operator to be more productive throughout the entire work shift.

**Demand Fan.** Demand fan changes speed to meet cooling requirements and save fuel.

**Engine Derate Feature.** Auto Derate monitors vital engine systems and will derate the engine horsepower up to 50% to protect the engine.

**Product Link Option.** Caterpillar's asset management or equipment management system called Product Link, enables dealers and their customers to track equipment for hours and location, and in some cases monitor machine health. This easy-to-use system provides information flow between a machine and the user through the internet based Dealer Storefront. This information helps lower operating costs through timely service/repairs and optimized machine use.

### **Machine Security System Option.**

The Machine Security System (MSS) inhibits unauthorized machine use by immobilizing vital electrical circuits. Critical machine circuits are inhibited unless a valid key is used to start the machine.

## Environmentally Responsible Design

*Caterpillar machines not only help you build a better world, they help maintain and preserve the fragile environment.*

**Low Fuel Consumption.** The 924G is the top performer in its size class. The result is more work done in a day, less fuel consumed and minimal impact on the environment.

**Low Exhaust Emissions.** The Cat 3056E DIT ATAAC is a low emission engine designed to meet current worldwide emission regulations and is Tier 2 compliant.

**Quiet Operation.** The engine cooling system allows the engine to be fully enclosed, allowing less engine noise to escape. With the optional sound suppression package, the 924G is even quieter.

**Ozone Protection.** To help protect the earth's ozone layer, the air conditioning unit uses only R-134a refrigerant which does not contain harmful chlorofluorocarbons (CFC's).

**Fewer Leaks and Spills.** Engine oil, transmission and hydraulic filters are positioned vertically and are easily removed without spillage. Cat O-ring face seals, XT hose and hydraulic cylinders are all designed to help prevent fluid leaks that can weaken the machine's performance and cause harm to the environment.

**Rebuildable Components.** All major components are designed for rebuildability.



### **Biodegradable Hydraulic Oil.**

Caterpillar biodegradable hydraulic oil can be used in the 924G, providing an environmentally-sound alternative to mineral-based oils.



# Complete Customer Support

*Caterpillar dealer services ensure a longer machine operating life with lower costs.*



**Operation.** For the best operating techniques to increase productivity and your profit, turn to your Cat dealer for the latest training literature and trained staff.

**Maintenance.** Choose from a wide range of maintenance services at the time of machine purchase. Repair option programs guarantee the cost of repairs up front. Diagnostic programs such as S•O•S Oil Analysis and Technical Analysis help avoid unscheduled repairs that can cost unnecessary time and money.

**Replacement.** Repair, rebuild or replace? Your Cat dealer can help you evaluate the cost involved to make the right choice.

**Product Support.** You will find nearly all parts at our dealer parts counter. Cat dealers utilize a worldwide computer network to find in-stock parts to minimize machine downtime. Additionally, Caterpillar offers a line of genuine remanufactured components which can help lower repair costs.

**www.CAT.com.** For more complete information on Cat products, dealer services, and industry solutions, visit us on the web at [www.CAT.com](http://www.CAT.com). Specializing in fast, accurate and up-to-date information, the Cat web site delivers the information you need to operate your business, 24-hours a day.

**Selection.** Make detailed comparisons of machines before purchasing. What are the job requirements? What production is needed? What is the true cost of lost production? Your Cat dealer can give you precise answers to these questions.

**Purchase.** Look at the value the 924G offers. Consider the financing options your Cat dealer offers as well as day-to-day operating costs. Dealer support services can be included in the cost of the machine to yield lower equipment owning and operating costs over the life of the machine.



## Engine

Model	Cat 3056E DIT ATAAC	
Flywheel Power	90.1 kW	121 hp
Max. Flywheel Power	98 kW	132 hp
Caterpillar	90 kW	121 hp
ISO 9249 (1997)	90 kW	121 hp
EEC 80/1269	90 kW	121 hp
SAE J1349:90	90 kW	121 hp
Bore	100 mm	3.94 in
Stroke	127 mm	5 in
Displacement	6 L	366 in <sup>3</sup>

- Ratings at 2300 RPM.
- Net power shown is the power available at the flywheel when the engine is equipped with air cleaner, fan, muffler and alternator.
- No derating required up to 3000 m (9,843 ft) altitude. Auto Derate protects hydraulic and transmission systems.
- The Caterpillar 3056E DIT ATAAC engine meets Tier 2 off-highway emission regulations.
- Features:
  - Electronically controlled rotary fuel pump
  - Three-ring, controlled-expansion, lubricated pistons
  - Gear-driven water and oil pumps
  - One-piece cast iron cylinder heads with two valves per cylinder
  - Fuel priming pump and fuel/water separator
  - S•O•S sampling port for engine oil
  - Replaceable dry liners
  - Cast aluminum valve cover
  - Radiator can be easily accessed for cleaning

## Engine Torque

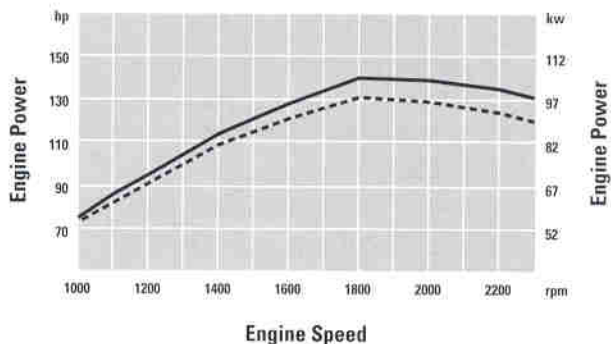
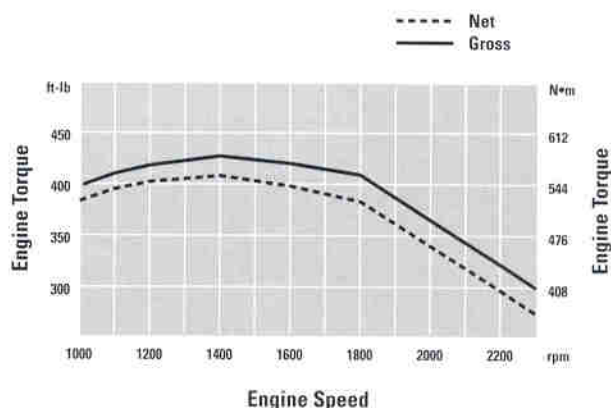

## Weights

Operating Weight 10 328 kg 22,769 lb

- Specifications shown are for 924G with optional counterweight, standard lubricants, full fuel tank, ROPS cab, 1.8 m<sup>3</sup> (2.3 yd<sup>3</sup>) bucket with bolt-on cutting edge, 80 kg (176 lb) operator and 17.5 - 25 PR (L2) tires.

## Steering

Minimum turning radius (over tire)	5070 mm	200 in
Steering angle, each direction	40°	
Steering cylinders, two, bore	69.9 mm	2.75 in
Hydraulic output at 2300 engine rpm and 6900 kPa (1000 psi)	106 L/min	27.7 gal/min
Maximum working pressure	20 685 kPa	3,000 psi

- Center-point frame articulation.
- Front and rear wheels track.
- Variable displacement piston pump provides steering power at all engine and ground speeds.
- Tilt steering console.
- High-impact rubber steering stops.
- Secondary steering system available to meet roading regulations in various countries, and to meet ISO 5010.

## Loader Hydraulic System

Output at 2300 engine rpm and 6900 kPa (1000 psi) with SAE 10W oil at 65°C (150°F)	152 L/min	39.5 gal/min
Maximum working pressure	25 900 kPa	3,755 psi
Hydraulic cycle time:		
Raise	5.1 Seconds	
Dump	1.4 Seconds	
Lower, empty, float down	2.4 Seconds	
Total	8.9 Seconds	
Lift cylinders, double acting:		
Bore	101.6 mm	4 in
Stroke	810 mm	31.9 in
Tilt cylinder, double acting:		
Bore	133.4 mm	5.25 in
Stroke	945 mm	37.2 in

- Load-sensing system provides only the flow and pressure needed to move the load.
- Variable-displacement axial piston implement pump.
- Low effort, hydraulic joystick controls.
- Electronic pilot shut-off switch disables implement functions for added safety.
- Hydraulic couplings with O-ring face seals.
- Optional heavy-duty oil cooler.
- Improved Ride Control system available to provide improved ride with less spillage from bucket during load & carry operations and better hard bank capability.

## Service Refill Capacities

Fuel tank	225 L	59.4 gal
Cooling system	40 L	10.6 gal
Crankcase	20 L	5.3 gal
Transmission	23 L	6.1 gal
Differentials and final drives:		
Front	21 L	5.5 gal
Rear	21 L	5.5 gal
Hydraulic system (including tank)	125 L	33 gal
Hydraulic tank	70 L	18.5 gal

## Transmission

Standard transmission, max travel speeds:		
Forward 1	6.7 kph	4.2 mph
Forward 2	12.2 kph	7.6 mph
Forward 3	21.8 kph	13.5 mph
Forward 4	38.5 kph	23.9 mph
Reverse 1	6.7 kph	4.2 mph
Reverse 2	12.2 kph	7.6 mph
Reverse 3	21.8 kph	13.5 mph
Optional low speed transmission, max travel speeds:		
Forward 1	3.7 kph	2.3 mph
Forward 2	7.5 kph	4.7 mph
Forward 3	19.6 kph	12.2 mph
Forward 4	39 kph	24.2 mph
Reverse 1	4.1 kph	2.5 mph
Reverse 2	8.1 kph	5 mph
Reverse 3	21.2 kph	13.2 mph

- Electronically-controlled Caterpillar countershaft transmission with full on-the-go directional and speed change capability.
- High-energy friction materials and thick reaction plates for better tolerance of heat.
- High-contact ratio spur gears are precision ground and heat treated for quiet, reliable operation.
- Electronic autoshift is standard.
- Button on implement control lever allows downshifting on demand.
- Computer controlled modulation provides smoother transitions.
- Optional low speed transmission available for better match with attachments requiring high hydraulic flow.

## Axles

### Features:

- Fixed front, oscillating rear ( $\pm 12^\circ$  with 17.5 - 25 L-2 tires).
- Caterpillar axle with fully-enclosed brakes and final drives.
- Patented Duo-Cone Seals between axle and housing.
- Rear wheel can raise or drop a total of:
  - 423 mm (16.6 in) with 17.5 tires, or
  - 326 mm (12.8 in) with 20.5 tires
- Limited Slip Differentials are optional on front, rear or both axles.
- Rear axle trunnion has remote lubrication fitting.
- Planetary final drives are lubricated from the main oil sump.
- High contact gearset reduces noise levels during meshing.

## Tires

---

Choice of:

- 17.5 - 25, 12PR (L-2)
- 17.5 - 25, 12PR (L-3)
- 17.5 R25, radial (L-2)
- 17.5 R25, radial (L-3)
- 550/65 R25, radial (L-2)
- 550/65 R25, radial (L-3)
- 20.5 - 25, 12PR (L-2)
- 20.5 - 25, 12PR (L-3)
- 20.5 R25, radial (L-2)
- 20.5 R25, radial (L-3)
- Other tire choices are available, contact your Cat Dealer for details.
- In certain applications, the loader's productive capabilities may exceed the tire's tonnes-km/h (ton-mph) capabilities. Caterpillar recommends that you consult a tire supplier to evaluate all conditions before selecting a tire model.

---

## Brakes

---

Features:

- Service brake:
  - Inboard oil-immersed disc brakes on front and rear axles are standard.
  - Completely enclosed and sealed.
  - Adjustment-free.
  - Separate circuits for front and rear.
  - Dual pedal braking system.
  - Fully integrated with hydraulic system, no air system required.
- Secondary brake:
  - Indicator light alerts operator if brake pressure drops.
  - Continually-charged nitrogen accumulators provide stopping power after loss of engine power.
- Parking brake:
  - Mechanical, shoe-type brake.
  - Mounted on drive line for positive manual operation.
  - Application of parking brake neutralizes the transmission.
- Optional heavy-duty brakes with integrated oil cooler.

## Cab

---

ROPS	SAE J1040 MAY94, ISO 3471-1994
FOPS	SAE J231 JAN81, ISO 3449-1992 Level II

- Caterpillar cab and Rollover Protective Structure (ROPS) are standard in North America and Europe.
- When properly installed and maintained, the cab offered by Caterpillar, when tested with doors and windows closed as per work cycle procedures specified in ANSI/SAE J1166 May 90, results in operator sound exposure Leq (equivalent sound pressure level) of 74 dB(A).
- As manufactured by Caterpillar, this machine's exterior sound power level meets the criteria spelled out in the European Directives noted on the certificate of conformance and the accompanying labeling.

---

## Bucket Controls

---

Features:

- Lift circuit:
  - Four positions: raise, hold, lower and float.
  - Adjustable automatic kickout from horizontal to full tilt.
- Tilt circuit:
  - Three positions: tilt back, hold and dump.
  - Two-speed dump for quick dumping with bucket and precise load control with forks or other work tools.
  - Adjustable automatic bucket positioner to desired loading angle.
  - Does not require visual spotting.
- Controls:
  - Choice of two low effort control systems: a joystick or a two-lever control of lift and tilt circuits.
  - Optional third and fourth function hydraulic circuits available with individual lever controls for remote hydraulic functions.
  - Controls can be disabled for roading.



# Dimensions with Bucket

All dimensions are approximate. Dimensions may vary with bucket. Refer to Operating Specifications.

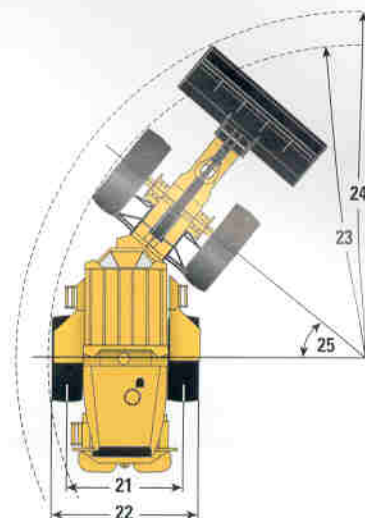
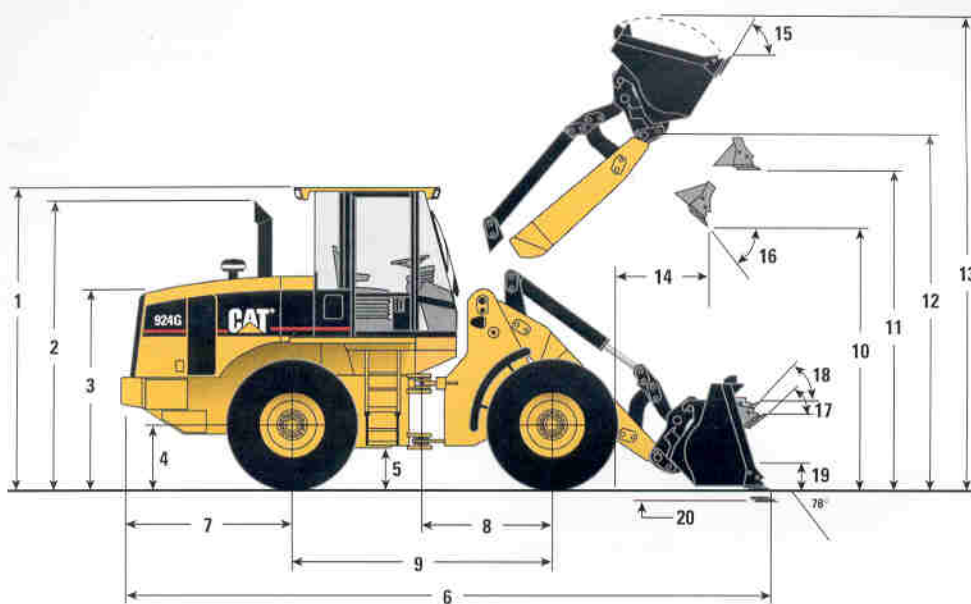

## Standard VersaLink

## High Lift VersaLink

	Standard VersaLink	High Lift VersaLink
1 Height to top of ROPS/FOPS	3159 mm (10 ft 5 in)	3158 mm (10 ft 5 in)
2 Height to top of exhaust stack	3143 mm (10 ft 4 in)	3142 mm (10 ft 4 in)
3 Height to top of hood	2151 mm (7 ft 1 in)	2150 mm (7 ft 1 in)
4 Height to center of axle	624 mm (2 ft 1 in)	624 mm (2 ft 1 in)
5 Ground clearance	368 mm (1 ft 2 in)	367 mm (1 ft 2 in)
6 Overall length	7168 mm (23 ft 6 in)	7659 mm (25 ft 2 in)
7 Length – rear axle to bumper	1923 mm (6 ft 4 in)	1923 mm (6 ft 4 in)
8 Center line of front axle to hitch	1400 mm (4 ft 7 in)	1400 mm (4 ft 7 in)
9 Wheel base length	2800 mm (9 ft 2 in)	2800 mm (9 ft 2 in)
10 Dump clearance at maximum lift and 45° dump	2760 mm (9 ft 1 in)	3267 mm (10 ft 9 in)
11 Bucket clearance at maximum lift and level	3488 mm (11 ft 5 in)	3995 mm (13 ft 1 in)
12 Bucket pin height at maximum lift	3813 mm (12 ft 6 in)	4319 mm (14 ft 2 in)
13 Overall height – bucket raised	5110 mm (16 ft 9 in)	5616 mm (18 ft 5 in)
14 Reach at maximum lift and 45° dump	1067 mm (3 ft 6 in)	1068 mm (3 ft 6 in)
15 Rack back angle at maximum lift	58°	62°
16 Dump angle at maximum lift	45°	45°
17 Rack back angle at ground	50°	50°
18 Rack back angle at carry	51°	54°
19 Carry height	367 mm (1 ft 2 in)	524 mm (1 ft 2 in)
20 Digging depth	132 mm (5 in)	143 mm (5.5 in)

Dimensions listed are for machines equipped with 17.5-25 12PR (L-2) tires and 1.8 m<sup>3</sup> (2.3 yd<sup>3</sup>) general purpose bucket with bolt-on cutting edge. Refer to Operating Specifications for bucket variations.

## 17.5-25 12PR (L-2) Tires

## 20.5-25 12PR (L-2) Tires

	17.5-25 12PR (L-2) Tires	20.5-25 12PR (L-2) Tires
21 Width at tread center	1880 mm (6 ft 2 in)	1880 mm (6 ft 2 in)
22 Overall width over tires	2356 mm (7 ft 9 in)	2466 mm (8 ft 1 in)
23 Minimum turning radius over tire	5070 mm (16 ft 8 in)	5135 mm (16 ft 10 in)
24 Minimum turning radius over bucket	See chart	5840 mm (19 ft 2 in)
25 Steering angle – left/right	40°	40°
Change in vertical dimension	–	+68 mm (+3 in)

# Typical Material Densities – Loose

	kg/m <sup>3</sup>	lb/yd <sup>3</sup>
Basalt	1960	3305
Bauxite, Kaolin	1420	2394
Clay		
natural bed	1660	2799
dry	1480	2495
wet	1660	2799
Clay and gravel		
dry	1420	2394
wet	1540	2596
Decomposed rock		
75% rock, 25% earth	1960	3305
50% rock, 50% earth	1720	2900
25% rock, 75% earth	1570	2647
Earth		
dry, packed	1510	2546
wet, excavated	1600	2698
Granite		
broken	1660	2799
Gravel		
pitrun	1930	3254
dry	1510	2546
dry, 6-50 mm (0.2-2")	1690	2849
wet, 6-50 mm (0.2-2")	2020	3406

	kg/m <sup>3</sup>	lb/yd <sup>3</sup>
Gypsum		
broken	1810	3052
crushed	1600	2698
Limestone		
broken	1540	2596
crushed	1540	2596
Sand		
dry, loose	1420	2394
damp	1690	2849
wet	1840	3102
Sand and clay		
loose	1600	2698
Sand and gravel		
dry	1720	2900
wet	2020	3416
Sandstone	1510	2546
Shale	1250	2107
Slag		
broken	1750	2950
Stone		
crushed	1600	2698
Wood chips	400	680

## Bucket Selector

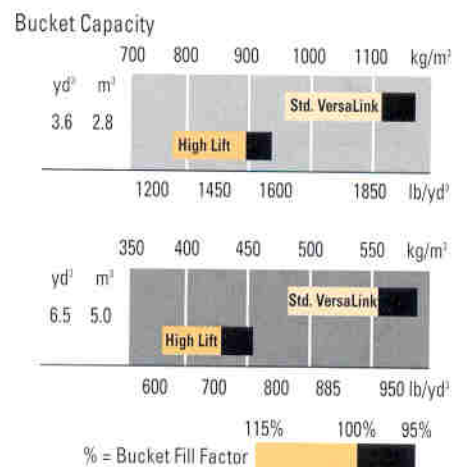
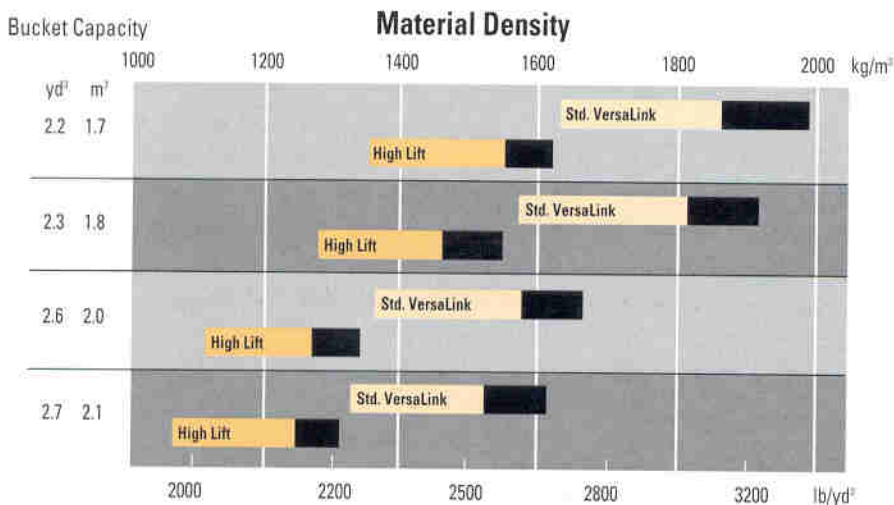



# Standard VersaLink

Operating Specifications with Bucket

Hook-on Buckets  
using Quick Coupler



		General Purpose						Waste/Ag	Woodchip
		Bolt-On Cutting Edge		Bolt-On Teeth & Segments*		Bolt-On Teeth*		Bolt-On Cutting Edge	Bolt-On Cutting Edge
Rated bucket capacity (\$)	m <sup>3</sup>	1.8	2.1	1.8	2.1	1.7	2.0	2.8	5.0
	yd <sup>3</sup>	2.3	2.7	2.3	2.7	2.2	2.6	3.6	6.5
Struck capacity (\$)	m <sup>3</sup>	1.5	1.7	1.5	1.7	1.4	1.6	2.3	4.1
	yd <sup>3</sup>	2.0	2.2	2.0	2.2	1.8	2.1	3.0	5.3
Bucket width	mm	2550	2550	2585	2585	2585	2585	2550	3392
	ft/in	8'4"	8'4"	8'6"	8'6"	8'6"	8'6"	8'4"	11'2"
10 Dump clearance at full lift and 45° discharge (\$)	mm	2760	2691	2656	2587	2656	2587	2555	2444
	ft/in	9'1"	8'10"	8'9"	8'6"	8'9"	8'6"	8'5"	8'0"
14 Reach at full lift and 45° discharge (\$)	mm	1067	1135	1170	1238	1170	1238	1273	1233
	ft/in	3'6"	3'9"	3'10"	4'1"	3'10"	4'1"	4'2"	4'1"
Reach at 45° discharge and 2130 mm (7'0") clearance (\$)	mm	1554	1584	1597	1622	1597	1622	1635	1516
	ft/in	5'1"	5'2"	5'3"	5'4"	5'3"	5'4"	5'4"	4'11"
Reach with lift arms horizontal and bucket level	mm	2370	2467	2516	2613	2516	2613	2660	2734
	ft/in	7'9"	8'1"	8'3"	8'7"	8'3"	8'7"	8'9"	8'11"
20 Digging depth (\$)	mm	132	140	132	140	107	115	157	132
	in	5"	5.5"	5"	5.5"	4"	4.5"	6"	5"
6 Overall length	mm	7168	7272	7168	7418	7291	7397	7479	7531
	ft/in	23'6"	23'10"	23'6"	24'4"	23'11"	24'3"	24'6"	24'9"
13 Overall height with bucket at full raise (\$)	mm	5110	5220	5110	5220	5110	5220	5342	5603
	ft/in	16'9"	17'2"	16'9"	17'2"	16'9"	17'2"	17'6"	18'5"
24 Loader clearance radius with bucket in carry position (\$)	mm	5603	5631	5662	5690	5662	5690	5689	6081
	ft/in	18'5"	18'6"	18'6"	18'8"	18'6"	18'8"	18'8"	19'11"
Static tipping load straight (\$)	kg	7491	7400	7325	7174	7504	7339	7151	6887
	lb	16,515	16,314	16,149	15,816	16,544	16,180	15,765	15,183
Static tipping load full 40° turn (\$)	kg	6529	6441	6362	6216	6531	6380	6207	6005
	lb	14,394	14,200	14,026	13,704	14,399	14,066	13,684	13,239
Breakout force (\$)	kg	9956	9130	9835	8970	10,545	9617	7806	7222
	lb	21,903	20,087	21,636	19,733	23,198	21,158	17,173	15,890
Operating weight	kg	10,328	10,376	10,463	10,560	10,377	10,426	10,490	10,854
	lb	22,769	22,875	23,067	23,281	22,877	22,985	23,127	23,929

Specifications shown are for machine with optional counterweight, standard lubricants, full fuel tank, ROPS cab, 80 kg (176 lb) operator and 17.5-25 12PR (L-2) tires.

\* Dimensions are measured to the tip of the bucket teeth to provide accurate clearance data. SAE standards specifies the cutting edge.

(§) Specifications and ratings conform to all applicable standards recommended by the Society of Automotive Engineers (SAE), including SAE Standards J732 JUN92 and J742 FEB85 governing loader ratings.

**Pin-on Buckets**

General Purpose						Waste/Ag	Woodchip
Bolt-On Cutting Edge		Bolt-On Teeth & Segments*		Bolt-On Teeth*		Bolt-On Cutting Edge	Bolt-On Cutting Edge
1.8 2.3	2.1 2.7	1.8 2.3	2.1 2.7	1.7 2.2	2.0 2.6	2.8 3.6	5.0 6.5
1.5 2.0	1.7 2.2	1.5 2.0	1.7 2.2	1.4 1.8	1.6 2.1	2.3 3.0	4.1 5.3
2550 8'4"	2550 8'4"	2585 8'6"	2585 8'6"	2585 8'6"	2585 8'6"	2550 8'4"	3392 11'2"
2850 9'4"	2781 9'2"	2746 9'0"	2677 8'9"	2746 9'0"	2677 8'9"	2645 8'8"	2518 8'3"
960 3'2"	1028 3'4"	1063 3'6"	1131 3'8"	1063 3'6"	1131 3'8"	1166 3'10"	1123 3'8"
1494 4'11"	1527 5'0"	1543 5'1"	1572 5'2"	1543 5'1"	1572 5'2"	1587 5'2"	1460 4'10"
2230 7'4"	2327 7'8"	2376 7'10"	2473 8'1"	2376 7'10"	2473 8'1"	2516 8'3"	2604 8'6"
132 5"	140 5.5"	132 5"	140 5.5"	107 4"	115 4.5"	157 6"	157 6"
7028 23'1"	7132 23'5"	7094 23'3"	7278 23'11"	7154 23'6"	7257 23'10"	7339 24'1"	7423 24'4"
5020 16'6"	5132 16'10"	5020 16'6"	5132 16'10"	5020 16'6"	5132 16'10"	5254 17'3"	5501 18'1"
5568 18'3"	5595 18'4"	5625 18'5"	5653 18'7"	5625 18'5"	5653 18'7"	5651 18'6"	6056 19'10"
7894 17,403	7821 17,242	7728 17,037	7593 16,740	7914 17,447	7759 17,106	7556 16,658	7219 15,915
6895 15,201	6826 15,049	6728 14,833	6599 14,548	6904 15,221	6764 14,912	6578 14,502	6243 13,764
11 452 25,195	10 405 22,891	11 330 24,925	10 243 22,535	12 251 26,952	11 052 24,315	8757 19,265	8050 17,710
10 206 22,500	10 234 22,562	10 342 22,800	10 416 22,963	10 256 22,611	10 284 22,672	10 350 22,818	10 688 23,563



# High Lift VersaLink

Operating Specifications with Bucket

Hook-on Buckets using Quick Coupler 		General Purpose						Waste/Ag	Woodchip
		Bolt-On Cutting Edge		Bolt-On Teeth & Segments*		Bolt-On Teeth*		Bolt-On Cutting Edge	Bolt-On Cutting Edge
Rated bucket capacity (\$)	m <sup>3</sup> yd <sup>3</sup>	1.8	2.1	1.8	2.1	1.7	2.0	2.8	5.0
		2.3	2.7	2.3	2.7	2.2	2.6	3.6	6.5
Struck capacity (\$)	m <sup>3</sup> yd <sup>3</sup>	1.5	1.7	1.5	1.7	1.4	1.6	2.3	4.1
		2.0	2.2	2.0	2.2	1.8	2.1	3.0	5.3
Bucket width	mm ft/in	2550	2550	2585	2585	2585	2585	2550	3392
		8'4"	8'4"	8'6"	8'6"	8'6"	8'6"	8'4"	11'2"
<b>10</b> Dump clearance at full lift and 45° discharge (\$)	mm ft/in	3267	3198	3163	3094	3163	3094	3062	2951
		10'9"	10'6"	10'5"	10'2"	10'5"	10'2"	10'0"	9'8"
<b>14</b> Reach at full lift and 45° discharge (\$)	mm ft/in	1068	1136	1171	1240	1171	1240	1274	1233
		3'6"	3'9"	3'10"	4'1"	3'10"	4'1"	4'2"	4'0"
Reach at 45° discharge and 2130 mm (7'0") clearance (\$)	mm ft/in	1991	2026	2044	2076	2044	2076	2093	1989
		6'6"	6'8"	6'8"	6'10"	6'8"	6'10"	6'10"	6'6"
Reach with lift arms horizontal and bucket level	mm ft/in	2761	2858	2907	3004	2907	3004	3051	3124
		9'1"	9'4"	9'6"	9'10"	9'6"	9'10"	10'0"	10'3"
<b>20</b> Digging depth (\$)	mm in	143	151	143	151	118	126	168	143
		5.5"	6"	5.5"	6"	4.5"	5"	6.5"	5.5"
<b>6</b> Overall length	mm ft/in	7659	7761	7805	7907	7787	7890	7965	8022
		25'2"	25'6"	25'7"	25'11"	25'7"	25'11"	26'2"	26'4"
<b>13</b> Overall height with bucket at full raise (\$)	mm ft/in	5616	5726	5616	5726	5616	5726	5849	6110
		18'5"	18'10"	18'5"	18'10"	18'5"	18'10"	19'2"	20'1"
<b>24</b> Loader clearance radius with bucket in carry position (\$)	mm ft/in	5840	5870	5902	5933	5902	5933	5934	6311
		19'2"	19'3"	19'4"	19'6"	19'4"	19'6"	19'6"	20'8"
Static tipping load straight (\$)	kg lb	6123	6044	5962	5881	6114	5984	5834	5545
		13,499	13,325	13,144	12,965	13,479	13,193	12,862	12,225
Static tipping load full 40° turn (\$)	kg lb	5310	5233	5148	5070	5293	5173	5035	4739
		11,707	11,537	11,349	11,177	11,669	11,405	11,100	10,448
Breakout force (\$)	kg lb	9956	9130	9842	9014	10,565	9635	7802	7241
		21,903	20,087	21,653	19,873	23,244	21,197	17,164	15,931
Operating weight	kg lb	10,414	10,463	10,549	10,595	10,464	10,513	10,576	10,940
		22,959	23,067	23,257	23,358	23,069	23,177	23,316	24,119

Pin-on Buckets 	General Purpose						Waste/Ag	Woodchip
	Bolt-On Cutting Edge		Bolt-On Teeth & Segments*		Bolt-On Teeth*		Bolt-On Cutting Edge	Bolt-On Cutting Edge
1.8 2.3	2.1 2.7	1.8 2.3	2.1 2.7	1.7 2.2	2.0 2.6	2.8 3.6	5.0 6.5	
1.5 2.0	1.7 2.2	1.5 2.0	1.7 2.2	1.4 1.8	1.6 2.1	2.3 3.0	4.1 5.3	
2550 8'4"	2550 8'4"	2585 8'6"	2585 8'6"	2585 8'6"	2585 8'6"	2550 8'4"	3392 11'2"	
3358 11'0"	3290 10'9"	3254 10'8"	3185 10'5"	3254 10'8"	3185 10'5"	3153 10'4"	3025 9'11"	
961 3'2"	1029 3'4"	1064 3'6"	1132 3'8"	1064 3'6"	1132 3'8"	1168 3'10"	1124 3'8"	
1924 6'4"	1962 6'5"	1981 6'6"	2016 6'7"	1981 6'6"	2016 6'7"	2035 6'8"	1923 6'4"	
2621 8'7"	2718 8'11"	2767 9'1"	2864 9'5"	2767 9'1"	2864 9'5"	2911 9'7"	2995 9'10"	
142 5.5"	150 6"	142 5.5"	150 6"	117 4.5"	125 5"	167 6.5"	167 6.5"	
7518 24'8"	7620 25'	7664 25'2"	7766 25'6"	7649 25'1"	7749 25'5"	7965 26'2"	7909 25'11"	
5527 18'2"	5639 18'6"	5527 18'2"	5639 18'6"	5527 18'2"	5639 18'6"	5762 18'11"	6008 19'9"	
5801 19'0"	5831 19'2"	5862 19'2"	5892 19'4"	5862 19'3"	5892 19'4"	5892 19'4"	6285 20'7"	
6436 14,189	6377 14,059	6275 13,834	6213 13,697	6432 14,180	6317 13,927	6156 13,572	5823 12,838	
5597 12,339	5540 12,214	5435 11,982	5377 11,854	5585 12,313	5480 12,081	5332 11,755	5000 11,023	
11 445 25,180	10 396 22,871	11 332 24,930	10 282 22,668	12 268 26,990	11 064 24,341	8747 19,243	8050 17,710	
10 293 22,692	10 321 22,754	10 428 22,990	10 456 23,052	10 342 22,800	10 370 22,862	10 439 23,014	10 774 23,753	



## Dimensions with Pallet Forks

All dimensions are approximate. Dimensions vary with fork length. Refer to Operating Specifications chart below.

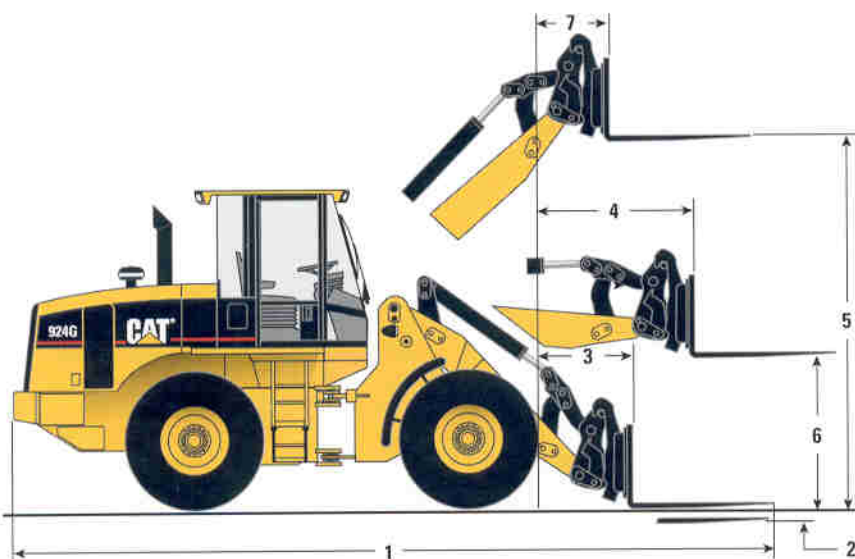

### Standard VersaLink

#### Fork Tine Length

	1200 mm (3 ft 11 in)	1350 mm (4 ft 5 in)
1	7607 mm (25 ft 0 in)	7772 mm (25 ft 6 in)
2	100 mm (4 in)	100 mm (4 in)
3	1007 mm (3 ft 4 in)	1022 mm (3 ft 4 in)
4	1636 mm (5 ft 4 in)	1651 mm (5 ft 5 in)
6	1722 mm (5 ft 8 in)	1722 mm (5 ft 8 in)
5	3569 mm (11 ft 8 in)	3584 mm (11 ft 9 in)
7	837 mm (2 ft 9 in)	837 mm (2 ft 9 in)

#### High Lift VersaLink

1	8104 mm (26 ft 7 in)	8269 mm (27 ft 2 in)
2	110 mm (4 in)	110 mm (4 in)
3	1503 mm (4 ft 11 in)	1518 mm (5 ft 0 in)
4	2027 mm (6 ft 8 in)	2042 mm (6 ft 8 in)
5	4076 mm (13 ft 4 in)	4091 mm (13 ft 5 in)
6	1722 mm (5 ft 8 in)	1722 mm (5 ft 8 in)
7	837 mm (2 ft 9 in)	837 mm (2 ft 9 in)

## Operating Specifications with Pallet Forks

### Fork Tine Length

#### Standard VersaLink:

	1200 mm (3 ft 11 in)	1350 mm (4 ft 5 in)
Operating load:		
Per SAE J1197 FEB91 (50% of FTSTL)	2462 kg (5416 lb)	2361 kg (5194 lb)
Per EN 474-3, rough terrain (60% of FTSTL)	2954 kg (6499 lb)	2833 kg (6232 lb)
Per EN 474-3, firm & level ground (80% of FTSTL)	3938 kg (8664 lb)	3778 kg (8312 lb)
Load center	600 mm (23.6 in)	675 mm (26.6 in)
Static tipping load with level arms and forks, straight*	5643 kg (12,441 lb)	5420 kg (11,949 lb)
Static tipping load with level arms and forks, full 40° turn*	4939 kg (10,889 lb)	4738 kg (10,446 lb)
Operating weight*	10 035 kg (22,123 lb)	10 095 kg (22,256 lb)

#### High Lift VersaLink:

Operating load:		
Per SAE J1197 FEB91 (50% of FTSTL)	2098 kg (4616 lb)	2015 kg (4433 lb)
Per EN 474-3, rough terrain (60% of FTSTL)	2518 kg (5540 lb)	2418 kg (5320 lb)
Per EN 474-3, firm & level ground (80% of FTSTL)	3357 kg (7385 lb)	3224 kg (7093 lb)
Load center	600 mm (23.6 in)	675 mm (26.6 in)
Static tipping load with level arms and forks, straight*	4868 kg (10,732 lb)	4666 kg (10,287 lb)
Static tipping load with level arms and forks, full 40° turn*	4228 kg (9321 lb)	4060 kg (8951 lb)
Operating weight*	10 121 kg (22,313 lb)	10 181 kg (22,445 lb)

\* Static tipping and operating weights shown are for machine with optional counterweight, lubricants, full fuel tank, ROPS cab, 80 kg (176 lb) operator and 17.5-25 12PR (L-2) tires. Tipping load is defined by SAE J732 JUN92.

## Dimensions with Standard VersaLink and Millyard Forks

All dimensions are approximate. Dimensions vary with fork length. Refer to Operating Specifications chart below.

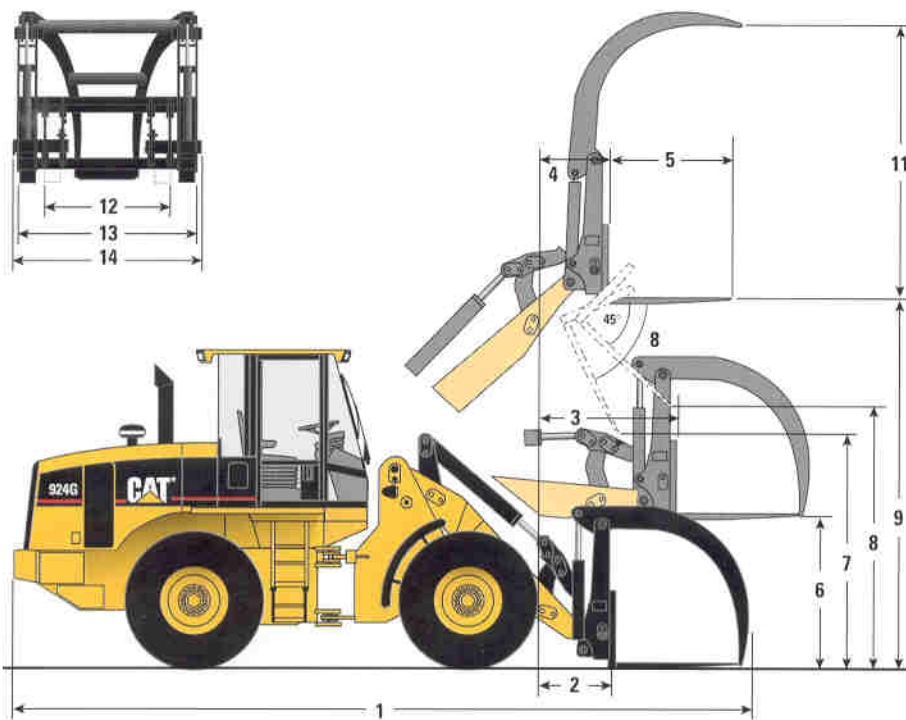

	Hook-On Fork		Pin-On Fork	
1	7670 mm	(25 ft 2 in)	7559 mm	(24 ft 10 in)
2	1044 mm	(3 ft 5 in)	940 mm	(3 ft 1 in)
3	1672 mm	(5 ft 6 in)	1511 mm	(5 ft 0 in)
4	873 mm	(2 ft 10 in)	712 mm	(2 ft 4 in)
5	1220 mm	(48 in)	1220 mm	(48 in)
6	1734 mm	(5 ft 8 in)	1668 mm	(5 ft 6 in)
7	2073 mm	(6 ft 10 in)	2423 mm	(7 ft 11 in)
8	2394 mm	(7 ft 10 in)	2465 mm	(8 ft 1 in)
9	3582 mm	(11 ft 9 in)	3515 mm	(11 ft 6 in)
10	69°		48°	
11	2705 mm	(8 ft 10 in)	2705 mm	(8 ft 10 in)
12	1195 mm	(3 ft 11 in)	1195 mm	(3 ft 11 in)
13	1651 mm	(5 ft 5 in)	1651 mm	(5 ft 5 in)
14	1779 mm	(5 ft 10 in)	1779 mm	(5 ft 10 in)

## Operating Specifications with Standard VersaLink and Millyard Forks

Fork Type	Hook-On Fork		Pin-On Fork	
Operating load:				
Per SAE J1197 FEB91 (50% of FTSTL)	2126 kg	(4677 lb)	2336 kg	(5139 lb)
Per EN 474-3, log handling, rough terrain (75% of FTSTL)	3189 kg	(7016 lb)	3505 kg	(7711 lb)
Per EN 474-3, log handling, firm & level ground (85% of FTSTL)	3614 kg	(7951 lb)	3972 kg	(8738 lb)
Load center	616 mm	(24.3 in)	592 mm	(23.3 in)
Static tipping load with level arm and forks, straight*	4959 kg	(10,933 lb)	5425 kg	(11,960 lb)
Static tipping load with level arm and forks, full 40° turn*	4268 kg	(9409 lb)	4689 kg	(10,338 lb)
Operating weight*	10 735 kg	(23,667 lb)	10 623 kg	(23,490 lb)

\* Static tipping and operating weights shown are for machine with optional counterweight, lubricants, full fuel tank, ROPS cab, 80 kg (176 lb) operator and 17.5-25 12PR (L-2) tires. Tipping load is defined by SAE J732 JUN92.



# Dimensions with Material Handling Arm

All dimensions are approximate.

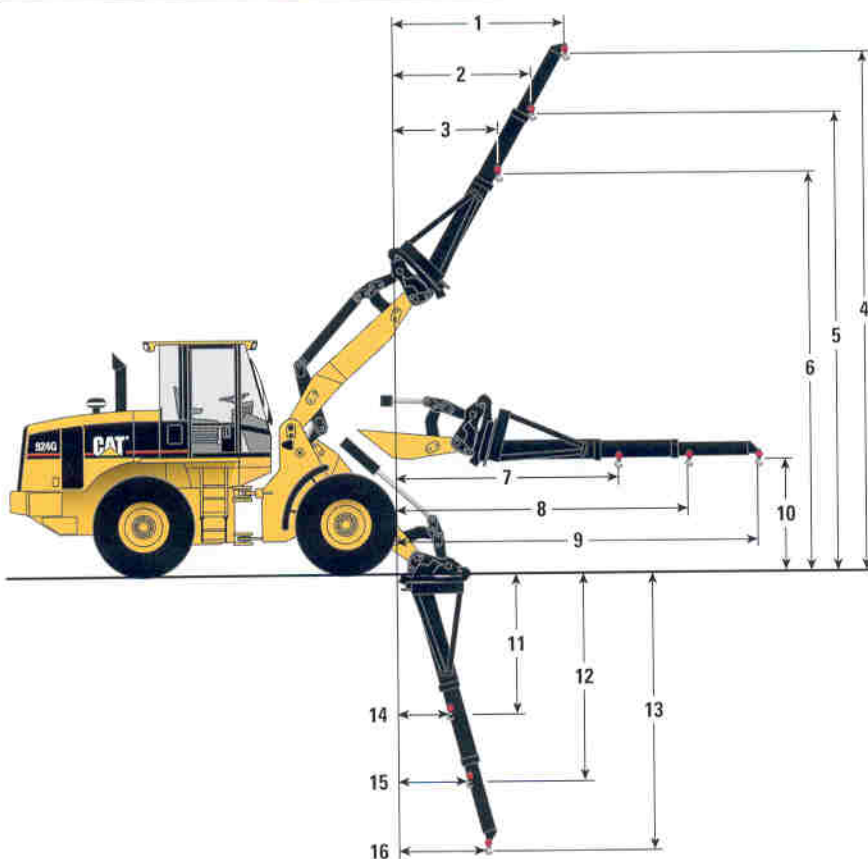

	Standard VersaLink	High Lift VersaLink
1	2430 mm (8 ft 0 in)	2152 mm (7 ft 1 in)
2	1956 mm (6 ft 5 in)	1745 mm (5 ft 9 in)
3	1482 mm (4 ft 10 in)	1339 mm (4 ft 5 in)
4	7129 mm (23 ft 5 in)	7785 mm (25 ft 6 in)
5	6249 mm (20 ft 6 in)	6872 mm (22 ft 6 in)
6	5370 mm (17 ft 7 in)	5959 mm (19 ft 7 in)
7	3296 mm (10 ft 10 in)	3687 mm (12 ft 1 in)
8	4295 mm (14 ft 1 in)	4685 mm (15 ft 4 in)
9	5295 mm (17 ft 4 in)	5686 mm (18 ft 8 in)
10	1534 mm (5 ft 0 in)	1533 mm (5 ft 0 in)
11	2206 mm (7 ft 3 in)	2131 mm (7 ft 0 in)
12	3156 mm (10 ft 4 in)	3035 mm (9 ft 11 in)
13	4107 mm (13 ft 6 in)	3939 mm (12 ft 11 in)
14	933 mm (3 ft 1 in)	1706 mm (5 ft 7 in)
15	1241 mm (4 ft 1 in)	2133 mm (7 ft 0 in)
16	1550 mm (5 ft 1 in)	2560 mm (8 ft 5 in)

## Operating Specifications with Material Handling Arm

Standard VersaLink:	Retracted	Mid-Position	Extended
Operating load	1790 kg (3938 lb)	1419 kg (3122 lb)	1178 kg (2592 lb)
Static tipping load, straight*	4097 kg (9013 lb)	3251 kg (7152 lb)	2698 kg (5936 lb)
Static tipping load, full 40° full turn*	3580 kg (7876 lb)	2838 kg (6244 lb)	2355 kg (5181 lb)
Operating weight*	9993 kg (22,031 lb)	9993 kg (22,031 lb)	9993 kg (22,031 lb)
<b>High Lift VersaLink:</b>			
Operating load	1576 kg (3467 lb)	1272 kg (2798 lb)	1068 kg (2350 lb)
Static tipping load, straight*	3623 kg (7970 lb)	2927 kg (6439 lb)	2459 kg (5410 lb)
Static tipping load, full 40° full turn*	3152 kg (6934 lb)	2544 kg (5597 lb)	2136 kg (4699 lb)
Operating weight*	10 079 kg (22,220 lb)	10 079 kg (22,220 lb)	10 079 kg (22,220 lb)

\* Static tipping and operating weights shown are for machine with optional counterweight, lubricants, full fuel tank, ROPS cab, 80 kg (176 lb) operator and 17.5-25 12PR (L-2) tires. Tipping load is defined by SAE J732 JUN92.

Note: Machine stability and operating weights are affected by tire size, tire ballast and other work tools.

# Supplemental Specifications

	Change in Operating Weight		Change in Articulated Static Tipping Load with Hook-On Bucket	
	kg	lb	kg	lb
Air conditioner	32	70	43	95
Canopy, ROPS (less cab)	-199	-438	-168	-370
Counterweight, 175 kg/385 lb (removal)	-175	-385	-267	-587
Guard, crankcase	15	33	20	44
Guard, driveshaft	17	37	3	7
Guard, power train	52	114	46	101
Ride Control System	40	88	25	55
Secondary steering	37	81	46	101
Tires, 1-piece rims				
17.5-25, 12PR (L-2)	0	0	0	0
17.5-25, 12PR (L-3)	72	158	41	90
17.5 R25, radial (L-2)	40	88	23	51
17.5 R25, radial (L-3)	140	308	79	174
Tires, 3-piece rims				
17.5-25, 12PR (L-2)	124	273	71	156
17.5-25, 12PR (L-3)	196	431	112	246
17.5 R25, radial (L-2)	164	361	94	207
17.5 R25, radial (L-3)	264	581	150	330
550/65 R25, radial (L-2)	456	1005	259	571
550/65 R25, radial (L-3)	516	1135	293	645
20.5-25, 12PR (L-2)	412	906	234	515
20.5-25, 12PR (L-3)	616	1355	350	770
20.5 R25, radial (L-2)	480	1056	273	600
20.5 R25, radial (L-3)	652	1434	371	816

# Standard Equipment

*Standard equipment may vary. Consult your Caterpillar dealer for details.*

## ELECTRICAL

- Alternator, 80-amp
- Alarm, back-up
- Batteries, maintenance-free, 950 CCA, (2)
- Directional signals (front & rear)
- Starting and charging system, 24V
- Halogen work lights (front & rear)
- Ignition key start/stop switch
- Roading lights
- Starting aid, thermal

## OPERATOR ENVIRONMENT

Cab, ROPS (sound suppressed and pressurized)

Gauges:

- Engine coolant temperature
- Hydraulic oil temperature
- Torque converter oil temperature
- Fuel level gauge
- Speedometer
- Digital tachometer
- Digital hour meter/odometer

Warning indicators:

- Primary steering malfunction
- Electrical system voltage low
- Coolant temperature
- Engine oil pressure low
- Parking brake applied
- Brake charge pressure low
- Transmission oil temperature
- Transmission oil filter bypass
- Hydraulic oil filter bypass

Adjustable tilt steering column

Coat hook

Ground level door release

Heater/defroster

Horn, steering wheel mounted (electric)

Hydraulic control lever lockout

Interior light

Interior and exterior auxiliary power sockets

Lighter

Lunch box storage with cup holder

Pilot hydraulic implement controls

Rear window defroster, electric

Rear view mirrors (2 inside)

Seat, adjustable suspension, armrest (fabric or vinyl)

Seat belt, 75 mm (3 in), retractable

Tinted safety glass

Tool box

Two door cab, fixed glass

Wet arm wiper/washer, intermittent, front & rear

## POWER TRAIN

Engine, Caterpillar 3056E DIT ATAAC

- Low emission diesel engine
- Turbocharged
- After cooled
- Electronically controlled engine

Air cleaner, dry type

Axle seal guards

Brakes, enclosed wet-disc full hydraulic

Differentials, conventional (front/rear)

Driveshaft, lubed for life

Engine fuel priming pump

Engine speed control

Fuel/water separator

Muffler

Radiator, unit serviceable

S•O•S<sup>SM</sup> oil sampling port, engine oil

S•O•S<sup>SM</sup> oil sampling port, transmission oil

Torque converter

Transmission, 4F/3R, autoshift, single lever control with  
F/N/R and kickdown button

Transmission neutralizer

## HYDRAULICS

Hydraulic diagnostic connectors

Hydraulic oil cooler

Hydraulic control, 2-valve, 1-lever with F/N/R

Load-sensing steering system

S•O•S<sup>SM</sup> oil sampling port, hydraulic oil

## OTHER STANDARD EQUIPMENT

Antenna, for radio

Antifreeze/coolant, extended-life protects to -36°C (-33°F)

Automatic bucket positioner/fork positioner

Brakes, secondary and parking

Bucket positioner, automatic

Counterweight

Engine enclosure, lockable

Fenders, front

Hitch, recovery

Loader linkage, VersaLink

Lift kickout, automatic

Machine Security System ready

Product Link ready

Remote grease lines

Steering stops, cushioned

Swing-out, hydraulically driven demand fan

Vandalism protection, lockable service points

Visual indicators:

- air cleaner service
- coolant level
- hydraulic oil
- transmission oil



## Optional Equipment

*Optional equipment may vary. Consult your Caterpillar dealer for details. All weights approximate.*

Air conditioner (R-134a refrigerant)  
Alternator, 95-amp  
Antifreeze/coolant, extended-life, protects to -50°C (-58°F)  
Beacon light, rotating, magnetic-mount  
Brakes, heavy duty  
Buckets/ground engaging tools  
Canopy, ROPS  
Counterweight, 175 kg (385 lb)  
Differential, Limited Slip, front axle and/or rear axle  
Differential, NoSpin, rear axle only (custom order)  
Dust bowl precleaner  
Electrical accessories package (12V converter, accessory plug outlet, wiring)  
Fan, reversing  
Fenders, roading, rear  
Fenders, steel  
Guards:  
- Crankcase  
- Power train  
- Vandalism protection (for use with ROPS canopy only)  
- Waste guarding package  
Hydraulic control, two lever (lift/tilt)  
Hydraulic control, third and fourth valve  
Hydraulic oil cooler, heavy-duty  
Flood lights, auxiliary, cab-mounted  
Linkage, high lift  
Load check valves (dealer installed)  
Low speed transmission

Machine Security System  
Material handling arm  
Mirrors, external (two)  
Pallet forks, carriage  
Product Link  
Quick Coupler, Caterpillar  
Quick Coupler, wide  
Radio prep package, 12V installation, includes speakers, cable, mounting bracket, hardware, converter and accessory plug. Radio not included.  
Ride Control System  
Seats:  
- Cat Contour Seat, fabric, with adjustable backrest and lumbar support.  
- Cat Contour Seat, fabric, electrically adjustable with air suspension.  
Sliding door windows (left and right)  
Sound suppression package  
Starting aid, engine coolant heater, 120V  
Steering, secondary  
Sun screen, rear  
Tires:  
- Bias ply, 17.5 - 25 and 20.5 - 25  
- Radial, 17.5 - 25, 550/65 R25 and 20.5 - 25  
Visor, sun (front)