

950G

Wheel Loader

CAT[®]



Cat[®] 3126 DITA diesel engine

Rated flywheel power 137 kW/183 hp

Maximum flywheel power 147 kW/197 hp

Bucket capacities 2.7 to 4.0 m³

Operating weight 18 047 kg

950G Wheel Loader

State-of-the-art design, engine performance and operator comfort maximize productivity.

Engine

Cat 3126 DITA diesel engine is built for performance, durability, excellent fuel economy, low sound levels and meets emission regulations. The 3126 has many heavy-duty features normally found on

- ✓ larger displacement engines. *A standard temperature sensing on-demand fan slows fan speed when temperatures are low – increasing available power and improving fuel efficiency.* **pg. 4**

Axles and Frame

Larger diameter axle shafts on the high torque side of the final drive provide greater torsional strength. Durable, articulated frame has a full box-section which absorbs twisting and impact forces to provide a solid foundation for the loader. *Axle oil temperature sensors are standard.* **pg. 6-7**

Operator Station

Ergonomically engineered using advanced virtual reality technology to provide the operator unparalleled comfort, spaciousness and viewing area. Control levers and gauges are ergonomically positioned to maximize productivity. **pg. 10-12**

Electronic Transmission

Planetary power shift transmission with automatic shift capability helps provide on-the-go speed and direction changes. The Electronic Clutch Pressure Control (ECPC) allow for smoother shifts and transmission neutralization, which let the operator adjust for specific site conditions.

- ✓ *Variable Shift Control (standard) allows the operator to match the shift pattern to the application, improving operator*
- ✓ *comfort and fuel efficiency. The Integrated Braking System (standard) integrates a downshifting and neutralizer logic into the left-hand brake pedal.* **pg. 5**

Hydraulics and Operator Controls

Enhanced, low-effort operator controls for steering, shifting and bucket loading precisely respond to operator input. Operator controls can be configured two ways – with Command Control steering and electro-hydraulic implement controls, or with Conventional steering and pilot hydraulic implement controls. **pg. 8-9**

Performance and comfort you can feel.
Caterpillar® design delivers excellent breakout force, fast load and cycle times, precise maneuvering and smoother shifts for optimal performance and comfort.

Reliability you can trust.
Proven components, field-tested durability, combined with easy maintenance, ensures reliability over the life of the machine.



✓ New Features

- On-demand fan (standard)
- Variable Shift Control (standard)
- Integrated Braking System (standard)
- Dedicated Quick Coupler Actuation Circuit (optional)

Environmental Machine

- ✓ Quieter operation with both the low sound and the *Blue Angel version*, availability of Cat biodegradable hydraulic synthetic ester based oil, combined with easy serviceability, help you meet or exceed current worldwide regulations and protect the environment. **pg. 13**

Buckets and Ground Engaging Tools

Choose from three bucket families, General Excavation, Rock V-edge and the newly designed Universal, combined with a large variety of Ground Engaging Tool options to allow precise application match. **pg. 14-16**

Serviceability

Easily perform daily maintenance up to 250-hour service intervals with ground-level access to all major service points including sight gauges for level checks of engine coolant, hydraulic and transmission oil. Most of these daily service points are located behind a lockable hinged door. The tilting hood provides unmatched access to the engine compartment and cooling system for larger maintenance jobs. **pg. 18**

Work Tools and Quick Couplers

- ✓ Add versatility to your machine with a wide range of attachments and special buckets offered by Caterpillar.
- ✓ Dedicated Quick Coupler actuation circuit. **pg. 17**

Preventive Maintenance

- ✓ Thanks to the Caterpillar Monitoring System, the Electronic Technician and the Scheduled Oil Sampling analysis, you can anticipate potential problems and avoid unscheduled repairs. **pg. 19**



3126 DITA Engine

The six-cylinder, direct injection, turbocharged and aftercooled (DITA) engine is built for power, reliability, low maintenance, excellent fuel economy and low emissions.

Powerful performance. The 3126 DITA engine delivers, at the rated speed of 2200 rpm, the flywheel power of 137 kW (183 hp), and meets all current worldwide emissions standards.

Four-stroke cycle design delivers long power strokes, efficient fuel combustion with low emissions, and excellent fuel economy.

Precise engineering and stringent testing help maintain a tradition of quality and offer built-in serviceability, profit-boosting performance, and heavy-duty durability and reliability.

Torque rise. The direct injected fuel system provides a controlled fuel delivery increase as the engine lugs back from rated speed. This results in increased horsepower above rated power. A combination of increased torque rise and maximum horsepower improves response, provides greater rimpull, more lift force and faster cycle times. The 147 kW (197 hp) maximum flywheel power occurs at 1650 rpm when power is needed during the working cycle.

Deep skirt engine block design ensures rigidity and reduces vibration.

Caterpillar engine oil is formulated to optimize engine life and performance and is strongly recommended for use in Cat diesel engines.

Factory remanufactured parts. A large choice of factory remanufactured parts and dealer proposed repair options increase machine availability and reduce total repair costs.

Cooling system features an on-demand, hydraulically driven fan for less radiator plugging, lower noise levels and reduced fuel consumption (by 3% to 5% or more). This results from a lower average fan speed, which depends on the coolant temperature.

Individual, high-pressure unit injectors atomize fuel efficiently for fast response, increased fuel economy with low emissions. The radius cone injector nozzle features a larger contact area with the cylinder head sleeve ensuring excellent sealing with the combustion chamber.

Water Separator and fuel pre-filter element, combined with two High Efficiency, 2-micron fuel filters, in series, provide optimum filtration ensuring excellent fuel cleanliness and extended injector life. Electric fuel priming pump is standard.

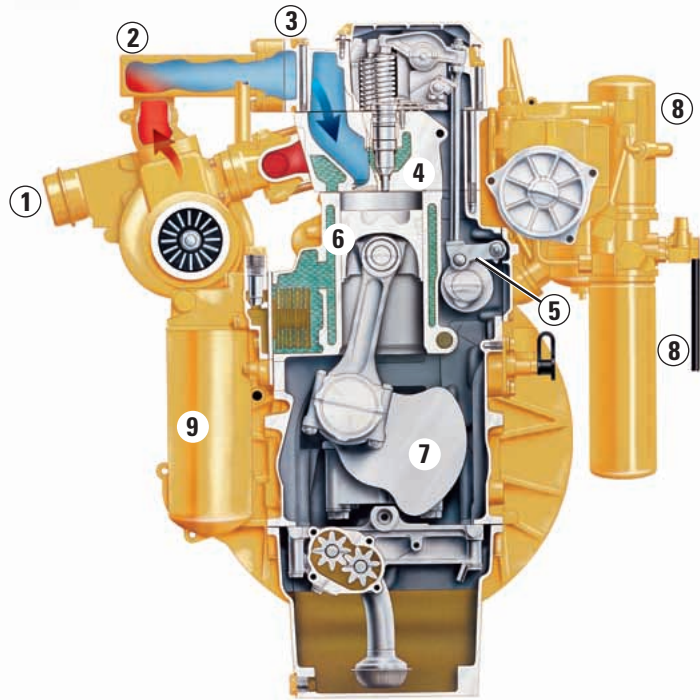

1 Turbocharger enhances performance and engine efficiency, especially at high altitude by packing more air in the cylinders for excellent combustion.

2 Jacket Water Aftercooler contributes to a cooler and more efficient combustion, reducing smoke and emissions as well as extending the life of piston rings and cylinder bore.

3 Air Intake Heater (optional on some configurations) eases cold starts. When coolant temperature is above 10°C, the air intake heater does not operate. When below 10°C, the length of the heating period automatically adjusts to the temperature.

4 Radius cone injector nozzle.

5 Camshaft roller followers reduce wear and frictional power losses for better durability and fuel economy. Followers and pushrods can be replaced without removing the camshaft.

6 Two-piece, articulated pistons with forged steel crown and forged aluminum skirt provide durability, lower engine sound levels and enhanced fuel efficiency with improved thermal and structural capability. The new Chrome Ceramic Surface (CCS) ring package, specifically developed for high load/high temperature applications, significantly improves engine block life.

7 Crankshaft is forged and induction hardened for long-term durability. Seven main journals and eight counterweights are dynamically balanced for smooth operation. The crankshaft is regrindable. Connecting rods can be removed through the tops of the cylinders for servicing ease.

8 Series fuel filters with ecological drain hoses and vent valve.

9 Large spin-on oil filter.

Electronic Transmission

Caterpillar power train makes dependable performance a standard feature.

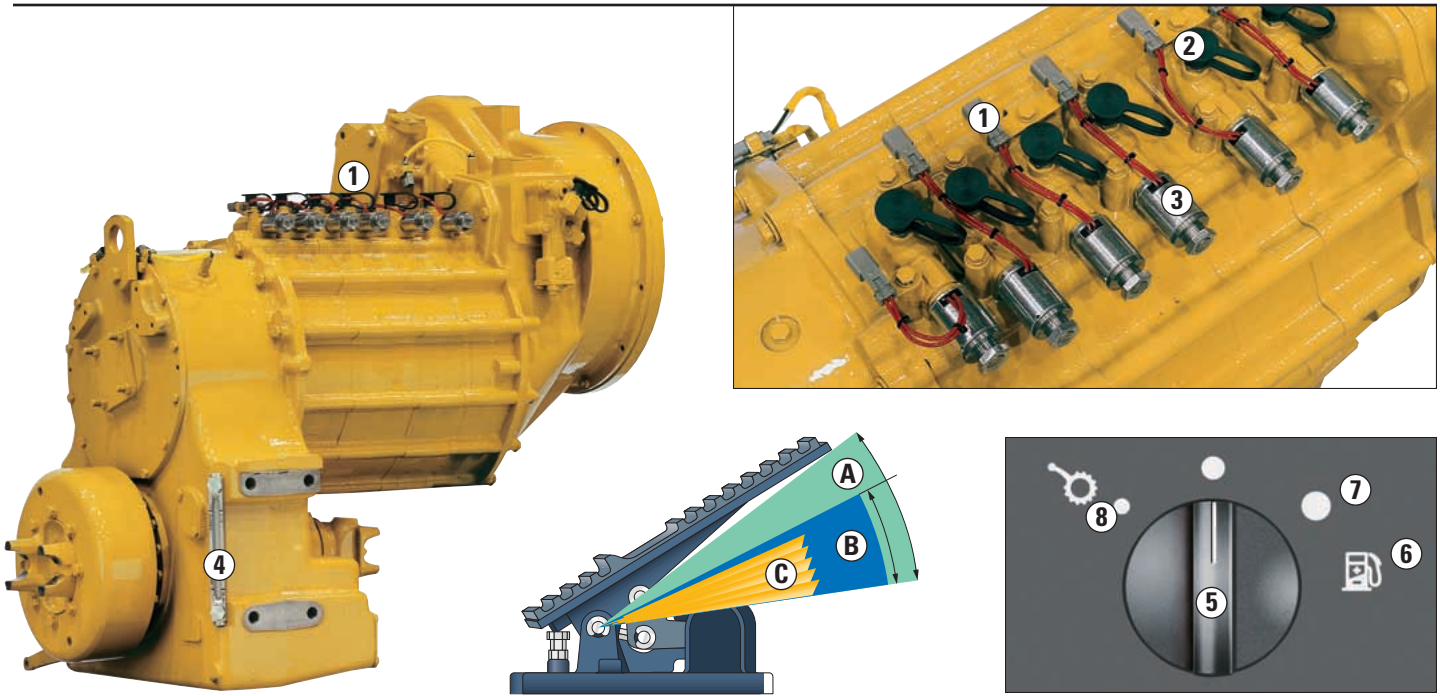

Electronic power shift transmission with automatic shift capability is designed, developed and built by Caterpillar.

The electronically controlled power shift transmission allows full-power, speed and directional changes. Fully modulated gear shifts significantly contribute to the operator comfort and increase machine productivity as well as component life.

Electronic Clutch Pressure Control (ECPC) senses input from both the transmission and the operator controls in the cab to modulate each individual clutch through a proportional electro-hydraulic valve. This results in smoother shifts in both speed and direction. Energy is modulated into the clutches, resulting in longer clutch life.

The Integrated Braking System (standard) integrates a downshifting and neutralizer logic into the left-hand brake pedal. This system translates into increased performance/productivity for the operator thanks to the optimized transmission neutralizer, the automatic downshifting and downhill retarding feature. The Integrated Braking System also lowers the owning and operating costs thanks to reduced axle oil temperatures, which can extend the brake life.

A Downshift logic only

B Brake application initiated

C Self-adjusting transmission neutralization

1 The six proportional electro-hydraulic valves pressurizing the clutches are identical and bolted on top of the transmission.

2 A dedicated pressure port is fitted on each electro-hydraulic valve to help reduce troubleshooting time for increased machine availability. By connecting the Electronic Technician (ET) and the service tool box, the transmission can easily be recalibrated to maintain quick response (see also page 19).

3 Heavy-duty thermoplastic connectors, sealed against moisture and contaminants, ensure reliable and trouble-free connections with the transmission control.

4 Easy service is built in the transmission. The daily level check is done from ground level through a well-protected sight gauge. An oil sampling valve allows quick, clean access to the transmission for S•O•S oil analysis.

5 Variable Shift Control (standard) is a new transmission software which allows the operator to select three different shift patterns based on his application and operating preference. This feature reduces fuel consumption by 2% to 6% or more, depending on the application. In all modes, the full machine power remains available for loading.

6 ISO symbol for fuel efficiency

7 Economy mode (typically used for load and carry and roading applications)

8 Standard mode (typically used for tight truck loading applications)

Caterpillar transmission oil has been developed to provide optimum friction control for power shift transmissions and brake disc material, as well as, to optimize transmission and final drive gear life.

Transmission neutralizer allows the operator to disengage the transmission clutches, removing torque from the drive train. With the neutralizer, high engine rpm's are maintained for full hydraulic flow and brake drive through is prevented.

Axles

Large, heavy-duty axles protect internal components from the harsh environment and offer excellent serviceability.

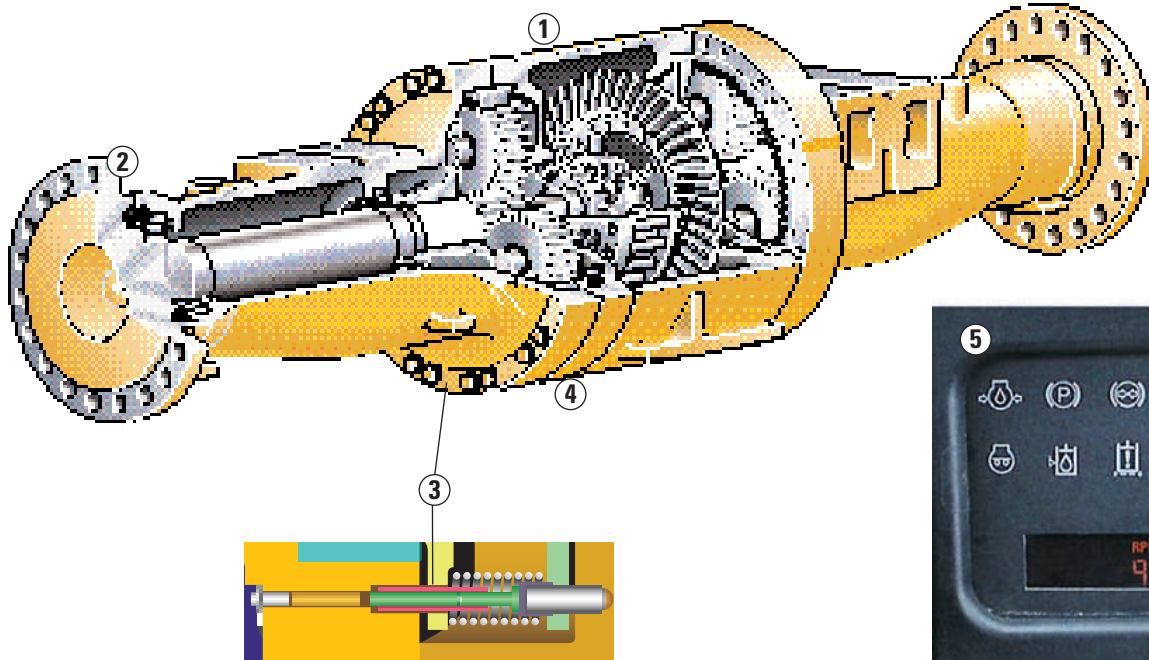

1 Heavy-duty axles and brakes

are designed to last in all kinds of operating conditions. Planetary final drives use full-floating, bronze sleeve bearings in the planet gears.

- The differential pinions use bronze spherical thrust washers for increased durability.
- Oil-disc brakes are adjustment free and fully enclosed to lock out contaminants.

2 Patented metal-to-metal, Duo-Cone Seals

between the axle shafts and housings keep lubrication in and dirt out.

3 An external port provides access to measure brake disc wear without disassembling the axle. The original brake measurement is recorded in the machine controls at the factory to allow precise wear calculation and schedule appropriate service.

4 The four-piece axle

contains two axle shaft housings, the center housing, and the intermediate housing. Features and benefits of this design include:

- Inboard brakes are positioned immediately adjacent to the differential and operate on the low torque side of the final drive, requiring less braking force to stop the machine.
- Independent front and rear brake circuits use separate, heavy-duty, piston-type accumulators to ensure dead engine braking.
- Brakes are bathed in axle oil for excellent cooling.
- Brakes can be serviced without disassembling the final drive.
- Larger diameter axle shafts on high torque side of final drive provide greater torsional strength for better performance and durability.

5 Axle oil temperature sensor

The axle oil temperature sensor is a preventive system that alerts the operator when oil temperature is too high. The operator then knows he must change his braking practices, or slow the machine.

The sensor is connected to the monitoring system. When the oil temperature reaches 125°C, a light flashes, and only switches off when the temperature goes below 117°C.

The front axle is rigidly mounted to the frame to support the weight of the wheel loader, internal torque loads and external loads applied during breakout and loading.

The rear axle includes a trunnion, two trunnion supports and the associated bearings, allowing it to oscillate plus or minus thirteen degrees, ensuring four-wheel ground contact for traction and stability, even on rugged terrain.

Limited slip differentials (optional on some configurations) deliver maximum traction on uneven ground and in changing traction conditions such as mud, water, snow and ice. They are available for front and/or rear axles.

Axle oil Ecology drains (optional) are available.

Frame

Superior engineering and materials provide excellent strength and durability.

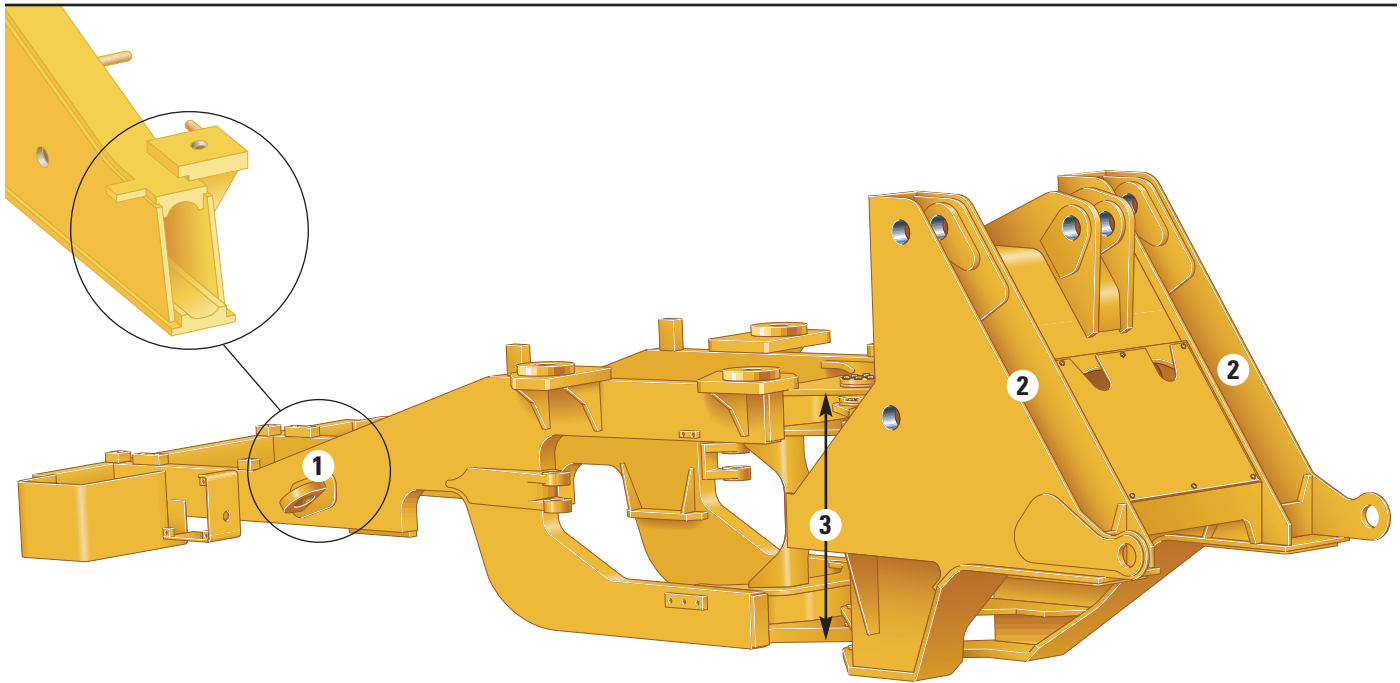

1 Full box-section rear frame has been designed to resist twisting and impact forces and serve as a strong base for the engine, transmission and rear axle.

2 Four-plate loader tower provides a solid foundation for lift arms, lift and tilt cylinders and front axle. This structure is built to resist severe torsional, impact and loading forces.

3 Spread-hitch design widens the distance between upper and lower hitch plates to distribute forces and increase bearing life. Thicker hitch plates and butterfly support reduce deflection. The wide opening allows good service access.

Upper and lower hitch pins pivot on double-tapered roller bearings. This design distributes vertical and horizontal loads over a greater surface area for longer life.

Frame structure designed for:

- Increased machine stability without sacrificing turning radius.
- Better loader performance and operating specifications.
- Improved serviceability to frame and components.

Frames were tested under severe applications including rock, hardbank digging, load and carry, bump course travel and bucket corner loading.

Hydraulics

Well balanced hydraulics deliver precise, low-effort control and trouble-free operation.



Low-effort hydraulic controls

allow the operator to precisely maneuver bucket lift and tilt.

- Electro-hydraulic controls, which are packaged together with Command Control steering, offer extremely low effort and great control. Automatic kickouts, switch-adjustable from inside the cab, allow the operator to set or modify upper and lower lift stops. Lift and tilt stops are hydraulically cushioned for greater operator comfort and less material spillage. There is one return-to-dig bucket tilt positioner, mechanically adjustable, on the linkage.
- Pilot valve controls, which come with Conventional steering, provide a familiar control environment that some operators may prefer. One lift and one return-to-dig position may be mechanically adjusted on the loader linkage.

Smooth, efficient steering.

Load sensing steering maximizes machine performance by directing power through the steering system only when needed. When the machine is not steering, more engine power is available to generate rimpull, breakout and lift forces. Load sensing reduces horsepower draw by up to 8 percent, resulting in increased fuel economy. Large-bore steering cylinders allow responsive maneuverability.

Hydraulic implement pumps

perform with high efficiency and great reliability. Increased flow rates result in faster hydraulics, for an optimum balance between machine ground speed and hydraulic lift speed, especially important in tight truck loading.

Pressure taps allow quick and easy diagnosis of all hydraulic system components.

Caterpillar's XT hose and couplings

are uniquely designed and tested to work together as a system for superior performance. Hoses are engineered and manufactured for high abrasion resistance, excellent flexibility and easy installation. Caterpillar couplings use pre-installed O-ring face seals which provide positive sealing for durable, leak-free connections. Reliable components reduce the risk of leaks, helping protect the environment.

A new Automatic Ride Control is an optional feature that helps operators perform better. This system uses a nitrogen over oil piston-type accumulator in the hydraulic lift circuit that acts like a shock absorber for the bucket. The lift arms and bucket response to movement is dampened over rough ground, reducing fore and aft pitch. A smoother, more comfortable ride gives operators the confidence to travel at higher speeds during load and carry, improving cycle times and load retention.

Caterpillar hydraulic oil offers maximum protection against mechanical and corrosive wear in all hydraulic systems. Its high zinc content reduces wear and extends pump life.

Operator Controls

Low-effort controls ease machine operation for increased comfort and efficiency.

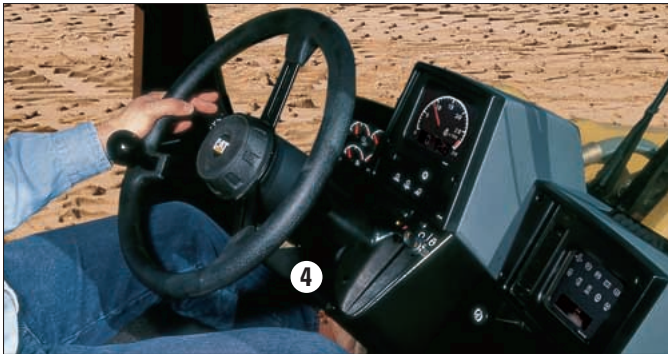

The 950G is available with two different configurations of operator controls – one with Command Control steering and electro-hydraulic implement controls, and another with Conventional steering and pilot hydraulic implement controls.

- 1 Command Control steering** allows one hand operation of steering and transmission controls. Turning the Command Control steering plus or minus 35 degrees, left or right, from centerpoint, achieves full machine articulation. Steering stops are hydraulically cushioned. Tilt and telescoping steering column helps fit the controls to the operator, ensuring optimum ergonomics.
- 2 Integrated transmission controls** are part of the steering design. Select forward, neutral or reverse with the three-position rocker switch. Use the thumb-operated rocker switch to manually upshift and downshift.
- 3 Finger tip implement control levers** require low operator effort and reduced travel. Operator can slide the right-hand armrest and control pod forward and back as a unit, and adjust the armrest cushion up and down to find the most comfortable position.
- 4 Conventional steering and pilot hydraulics** configuration is standard. Conventional steering uses a well-proven, hand-metering-unit hydraulic system. The lift control lever features a quick gear kickdown button, which lets the operator downshift easily to a lower gear. This version is also available with an optional third lever control.

Electronic Autoshift Control allows the operator to concentrate on the work, not on gear selection.

- On the Command Control steering configuration, the operator positions a console-mounted switch to select either manual mode or auto mode. In auto mode, the operator can select the highest gear the transmission will automatically up-shift to (2nd, 3rd or 4th) using the console-mounted switch. The transmission up-shifts (depending on the selected Variable Shift Control mode) so that each shift occurs at optimum torque and ground speed matching the application/operator requirements. Also, using the console-mounted switch the operator can select the lowest gear the transmission will automatically downshift to (1st or 2nd), through the Integrated Braking System (see also on pg. 5).
- On the Conventional steering configuration, the maximum gear the transmission will automatically up-shift to (2nd, 3rd or 4th) can be selected using the rotating gear selector and the lowest gear the transmission will automatically downshift to (1st or 2nd) by using the console-mounted switch.

Dual-pedal braking lets the left pedal function as a brake, but also integrates a transmission neutralizer and an automatic downshift logic (see also pg. 5). The right pedal functions as a regular brake. With the neutralizer, the operator can maintain high engine revolutions for full hydraulic flow (see also on pg. 10).

Transmission neutralizer lockout lets the operator shut the neutralizer off. This provides a choice to operators who prefer to operate without a neutralizer. It also provides excellent inching capability for utility work.

Operator Station with Command Control Steering configuration

The ultimate in wheel loader operator comfort and efficiency.



The 950G cab is a spacious and comfortable work environment that promotes productive operation.

The cab includes outstanding viewing area, ease of service, ergonomic design and controls placement, improved ventilation and generous storage areas.

1 Excellent viewing in all directions.

Extended windows open the operator's view for remarkable forward and peripheral viewing including machine wheels and bucket corners. Bonded glass in the windshield eliminates frame obstructions. The stylish, sloping hood improves the view to the rear by letting the operator see objects closer to the machine.

2 Command Control steering is optional and features a steering wheel, with integrated transmission controls. Ergonomically integrated into the controls are two rocker switches, one for the forward/neutral/reverse selection, the other for manual up/down shifting. Load-sensing steering with flow amplification matches steering response to application requirements. Tilt and telescopic steering column helps fit the controls to the operator.

3 Electro-hydraulic, finger tip, implement controls are optional and feature extremely low effort and precise hydraulic modulation capability. The controls are seat-mounted and adjustable for outstanding ergonomics. This attachment is packaged together with the Command Control steering inside the cab.

Other options available:

- Air conditioning
- Internal mirrors
- Working lights

4 Automatic lift/lower kickouts are part of the electro-hydraulic controls and easily adjustable from inside the cab thru a simple rocker switch operation. Kickout stops are hydraulically cushioned for greater operator comfort and less material spillage.

5 950G Monitoring System consists of gauges, tachometer/speedometer and 3-level warning to ensure full time monitoring of key functions. The system alerts the operator of immediate or impending problems with engine oil pressure, parking brake, brake oil pressure, charging system, brake oil temperature, hydraulic oil level, hydraulic filter bypass, primary and secondary steering oil pressures.

6 Left, rear-hinged door includes a sliding window and gives entrance and exit to the operator station. Swing open right-side plain glass window provides outstanding visibility to the side of the machine as well as a secondary exit if needed. The window opens partially and locks for additional ventilation.

7 Dual brake pedals serve brake, transmission neutralizer and downshift functions so the operator can maintain high engine revolutions for full hydraulic flow and high productivity.

8 Generous storage space includes:

- Coat hook.
- Molded compartments for lunchbox, cooler, thermos, cup or can.

9 Caterpillar Contour Series air suspension seat, which is standard on the Command Control steering version and optional on the Conventional steering version, is 6-way adjustable, providing comfort and support. The seat cushions reduce the pressure on the lower back and thighs, while offering unrestricted arm and leg movement. Air suspension adds to the overall comfort level by smoothing the ride over rough terrain. Seat is equipped with a 76 mm retractable seat belt.

10 Improved ventilation for better air flow to the operator and windows. There are twelve louvered vents with two on each door post. A large recirculation filter ensures better air quality and contributes to the operator comfort.

11 Electronic Autoshift control (see also pg. 9).

12 Ride Control System switch allows the selection of three different modes:

- Off: permanently off service.
- On: permanently in service.
- Auto: in this mode, the system will automatically be actuated when the machine travels at a speed greater than 9 km/h (which is adjustable) and will be turned off below 9 km/h.

13 Transmission neutralizer lockout (see also pg. 9).

14 Radio ready cab includes a 12-volt converter (5-amp), speakers, antenna, all wiring and brackets for entertainment or communications radio installation.

15 Payload Control System is an optional attachment, specifically designed for Cat wheel loaders. This system features improved on-the-go weighing as well as a broader weighing range, and is less sensitive to the various operator techniques. On-the-go weighing during the lift cycle helps the operator meet maximum loader productivity, while stationary weighing allows for reweighs and partial dumps, both modes achieving precise loading with a high level of accuracy.

16 Exterior rear-view mirror package includes two large, curved mirrors, solidly mounted on strong brackets to keep them well adjusted and avoid vibrations.

17 Variable Shift Control (standard), allowing the operator to select three different shift patterns based on application and working preferences.

Operator Station with Conventional Steering configuration

Top-quality comfort and operator controls will help maximize productivity.

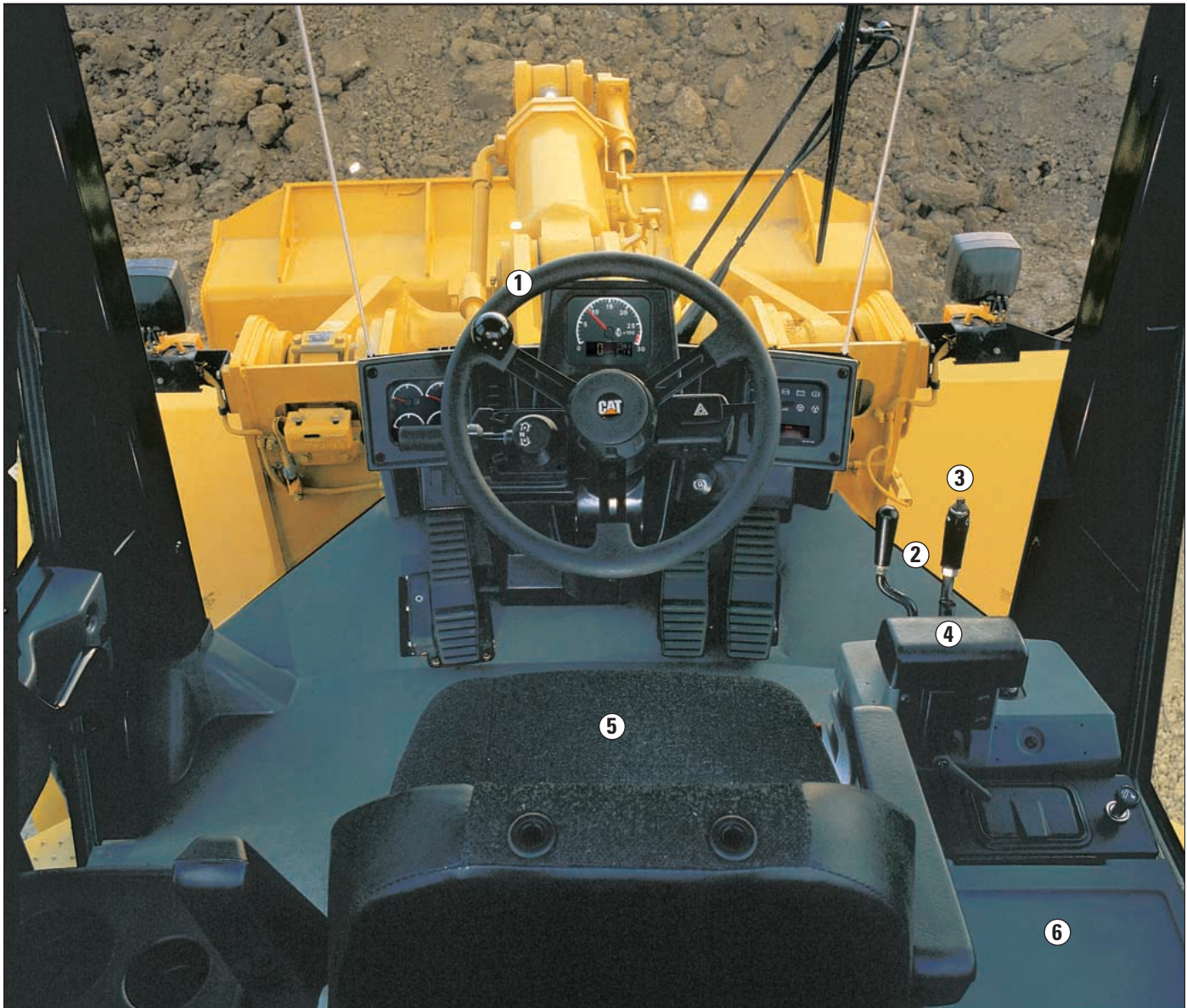

1 Conventional steering wheel

is low-effort, offers a good grip and is tiltable for maximum comfort.

2 Pilot-assisted, hydraulic implement controls

make low-effort operation possible.

3 Quick gear kickdown button

lets the operator downshift easily to a lower gear, saving time, increasing bucket fill factors and lowering cycle times.

4 Padded, adjustable wrist rest

helps reduce fatigue.

5 Seat options. The standard seat has adjustable fore/aft position, seatback angle, lumbar support, bottom cushion height, armrest angle and suspension stiffness. The seat trim is a combination of durable fabric and vinyl. Available as an option is the Caterpillar Contour seat featuring added support and an electrically adjustable air suspension. Both seat versions are equipped with a 76 mm retractable seat belt.

6 Lockable compartment integrated in the hydraulic implement controls console offers a good storage for personal items.

Other options available for the 950G operator station:

- Air conditioning that uses blended air for quick temperature changes and R-134a refrigerant which does not contain chlorofluorocarbons. Quick-connect couplings allow easy removal from the cab with no release of refrigerant.
- Internal mirrors package.

Environmental Machine

Caterpillar cares about the environment and continues to develop innovative solutions.



Building further on our product developments that were awarded the 'Blue Angel'* certificate for sound reduction by the German Federal Environmental Administration and pursuing Caterpillar's dedication to design products that are respectful of the environment, the 950G broadens our offerings and features two specific configurations.

The low sound version is two times quieter than the standard machine and is at 105 and 73 dB(A) for exterior and operator station respectively. To achieve these sound levels, following modifications are made:

- A noise wall isolating the engine from the cooling package.
- An on-demand fan (standard on all 950G), which automatically regulates the fan speed depending on the cooling requirements
- Reverse cooling system, which takes the fresh air from the back of the machine, through the cooling system and rejects through three perforated panels at the top and side of the machine
- Additional sound insulation around the engine

This design results in a quieter vehicle, reduced fuel consumption and an easier to clean radiator package.

* 'Blue Angel' certificate is from the 'RAL Deutsches Institut für Gütesicherung und Kennzeichnung e.V.'

The Blue Angel version further builds on the low sound platform in order to comply with the RAL German Institute for Quality Assurance and Certification's 'Blue Angel'* sound regulation and is rated at 101 and 72 dB(A) for exterior and operator sound levels respectively. This Blue Angel version is approximately two times quieter than the low sound version and four times quieter than the standard vehicle.

Environmental Fluids complete the offering with two specific products.

- Extended Life Coolant/Antifreeze with anti-foaming and anti-corrosion properties provides extended service intervals (up to 6000 hours) requiring less frequent fluid renewals and disposals. This is a standard feature.
- Cat Bio Hydo (HEES) is formulated from a fully saturated Hydraulic Environmental Ester Synthetic base stock and selected additives. It has excellent high-pressure and high-temperature characteristics. Provided a special water separator filter has been installed and depending on regular S•O•S analysis, Cat Bio Hydo (HEES) service intervals can be extended up to 6000 hours. It is fully compatible with our hydraulic components and allows operation over a broad temperature range. Cat Bio Hydo (HEES) is fully decomposed by soil or water microorganisms. This is available as an attachment.

Low exhaust emissions. The Cat 3126 DITA engine used in the 950G is a low emission engine designed to meet current emission regulations. Governor fuel-to-air ratio control, cylinder head and pistons, combined with a jacket water aftercooler, provide more efficient combustion, lower fuel consumption and cleaner emissions.

Fewer leaks and spills. Transmission and hydraulic oil filters, as well as engine oil and fuel filters are spin-on elements, positioned vertically and purposely located for a quick and easy access allowing their removal without fluid spillage. Lubricant fillers and drains are also designed to avoid spills.

Ecology drains for the engine, transmission, hydraulics, radiator and fuel are standard from factory. They replace the standard drain plugs. Activating the valve allows fluid to be drained into a container without spillage. Axle oil ecology drains are optional and allow quicker oil changes, eliminate spillage and reduce the time/risk of clean up.

Rebuildable components. Many of the major components used in the 950G are designed for rebuildability. That means you have high-quality, remanufactured (REMAN) parts available to you at a fraction of the new component cost.

Cat Buckets and Ground Engaging Tools

Three bucket families and a large choice of Ground Engaging Tools maximize performance in all applications.

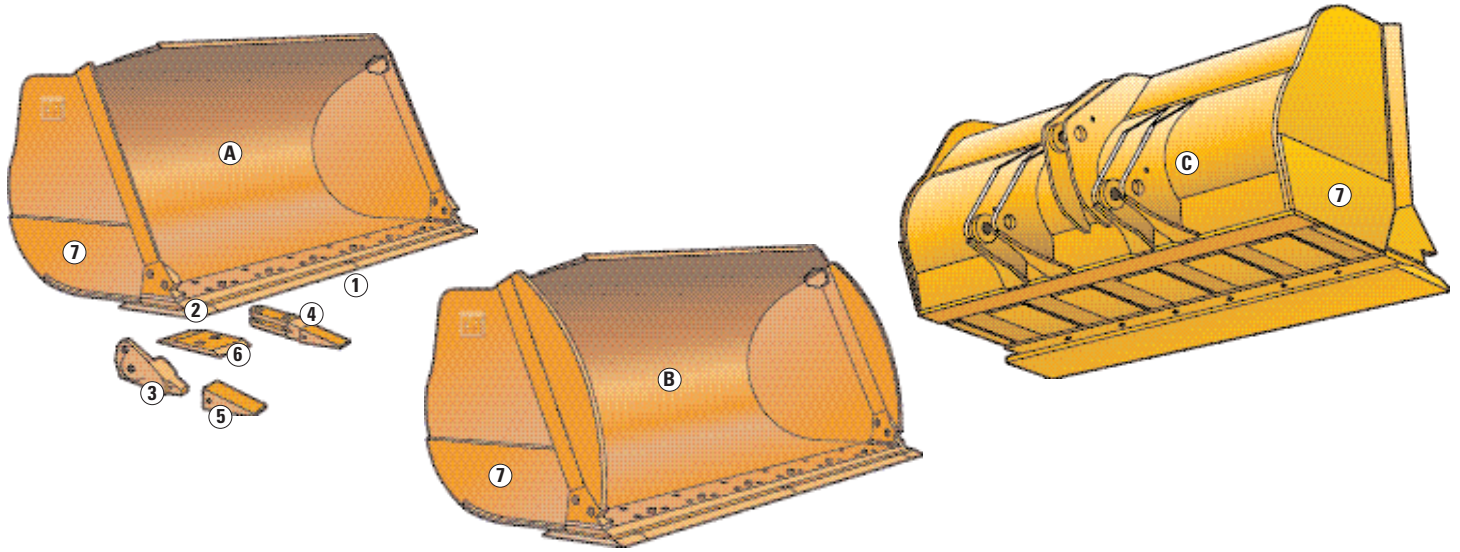

A Standard Universal buckets.

This is a new line of flat floor buckets featuring an optimized design. Equipped with various Ground Engaging Tools, they provide easier pile penetration, better fill factors and faster loading cycles; they are offered in a wide range of capacities and are recommended in all applications, except fulltime bank or rock loading. All buckets feature integral spill plates to prevent rear spillage, as well as, bottom and side wear plates for greater durability. In order to better meet the various application criteria, the Universal bucket line is available in different configurations:

B Universal buckets with Rounded Side Plates.

This provides an excellent load retention in aggregates application, especially in load-and-carry cycles.

C Universal buckets with Back Grading Edge.

In this configuration, an additional full-width box-section profile with a wear edge is welded at the back of the bucket floor. The bucket base edge and the additional rear edge are at the same level, providing better grading capabilities. This bucket can be fitted with welded flush mounted adapters and tips still allowing excellent grading capability.

Corner guard system allows maximum flexibility between teeth and edge systems for superior protection and performance in each application.

Bolt-on cutting edge (1) and end bits (2)

- Standard DH-2, reversible, for superior strength and wear life.
- Heavy-duty, reversible, providing 50% more wear life.
- Abrasion Resistant Material (ARM) with impregnated tungsten carbide is another option for maximum wear life in low-to-medium impact application.

Bolt-on teeth

- New two-bolt corner adapter (3) securely attached to prevent shifting.
- Bolt-on two-strap center adapters (4).
- Seven tip options with Heavy-duty retention system. (5).

Bolt-on teeth and edge segments

- Standard reversible segments (6) protect the base edge between teeth, eliminating scalloping and maintaining a smooth work surface.
- Heavy-duty reversible segments for 50% more wear life.

Replaceable side wear plates (7)

for greater durability.

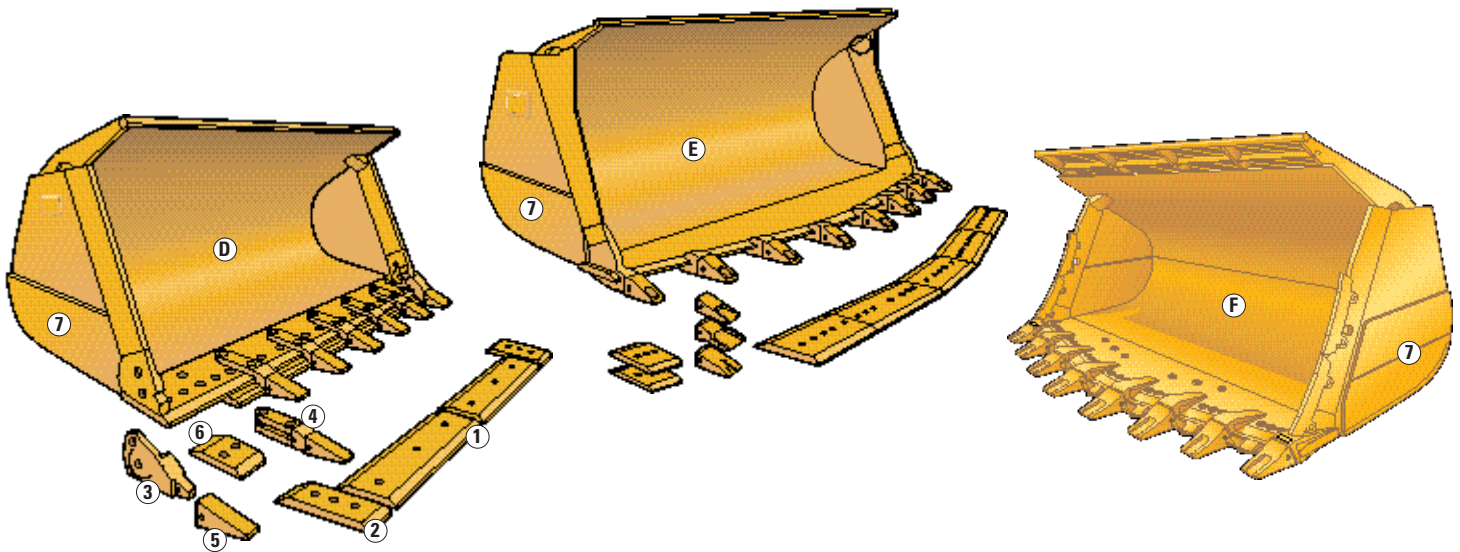

D General Excavation Buckets.

All General Purpose buckets have been renamed as General Excavation buckets to better reflect their application spectrum. Built to handle the toughest conditions, they feature a well proven, shell-tine construction design that resists twisting and distortion and are excellent for bank and excavation applications. Bucket hinges are part of a structure that extends under the bucket shell to the cutting edge, forming box sections. These structures act as protection against impact and twisting forces. All buckets have integral spill plates that prevent rear spillage, keeping material away from the linkage. Replaceable through-hardened weld-on rear wear plates protect the bottom of the bucket for greater durability. Bucket side plates are also reinforced in their lower portion with additional wear plates for longer life.

E Rock Buckets. Cat rock buckets are built to tough standards. The spade-edge design provides easier penetration and makes them well suited to high-impact jobs. Ground Engaging Tools include bolt-on cutting edge or weld-on two straps adapters to be fitted with J350 tips, with or without standard or heavy-duty bolt-on segments.

F Heavy Duty Rock Buckets offer superior protection and durability. Specifically designed for the toughest quarry, aggregates and mining operations, these buckets are factory-modified with additional protection: Liner; dual sidebar protectors; inner and outer side wear plates; outer skid plates; base edge, rear and hinge bracket wear plates; Heavy duty long life (A.R.M) corner adapters; Heavy duty adapters, tips and segments. Each protection item was carefully chosen in response to customer requests for bucket that delivers maximum strength, durability and wear life in high impact/high abrasion conditions. These components are designed to reduce down time and bucket-related operating cost to help you get the most from your machines.

Tip Selection and GET System Selection Guide

Seven tip options are available to provide the best combination of wear life, penetration and strength needed for each application.

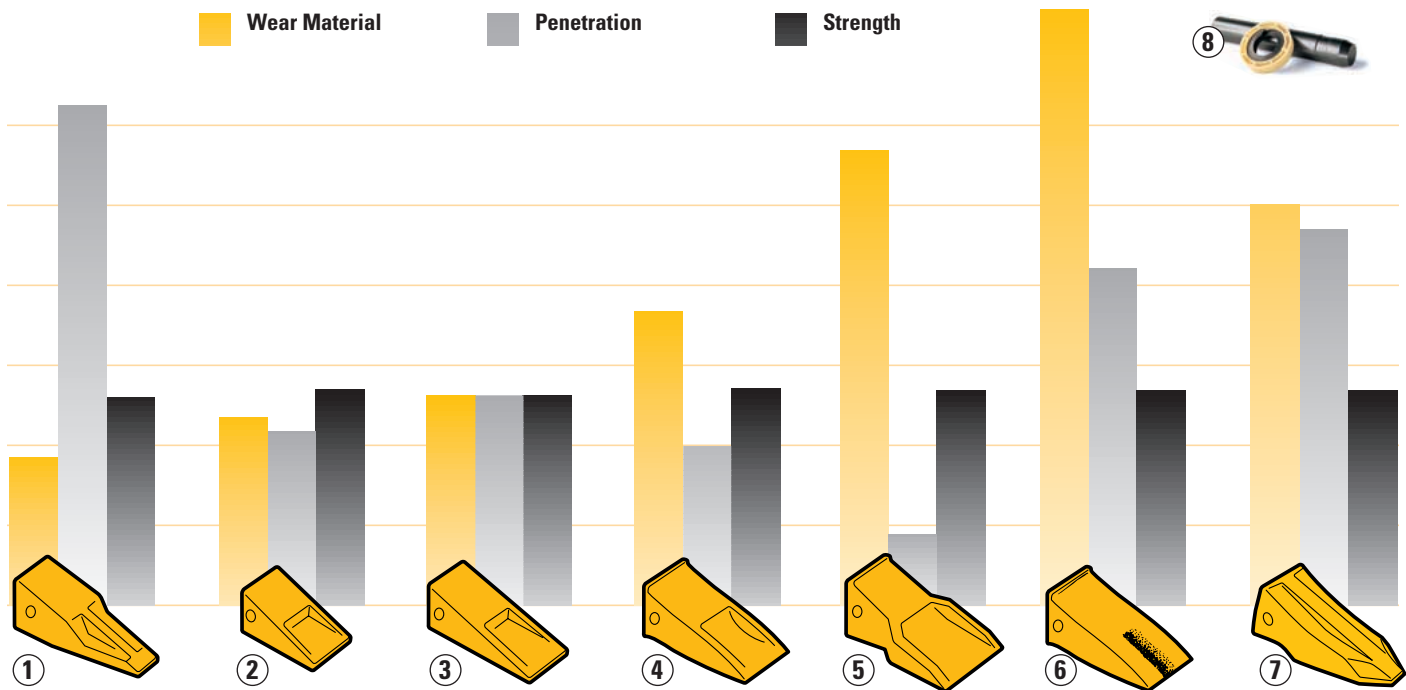

1 Penetration

- Use in densely compacted material such as clay.
- Gives maximum penetration.
- Self-sharpening.

2 Short

- Use in high-impact and pry-out work such as rock.
- Extremely strong.

3 Long

- Use in most general applications where breakage is not a problem.

4 Heavy Duty Long

- Use in general loading and excavation work.
- Has extended wear life and greater strength

5 Heavy Duty Abrasion

- Use when working in sand, gravel and shot rock.
- Maximum wear material.

6 Heavy Duty Long Life

- A.R.M. positioned to increase wear life and penetration.
- As the Heavy Duty Long Life tip wears, ease of penetration increases.

7 Heavy Duty Penetration

- Use in high-impact, hard-to-penetrate material.
- Extended wear life.

8 Heavy Duty retention system

- eliminates pin walking and the resultant tip loss in particularly severe loading conditions.

GET system selection guide

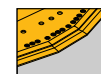
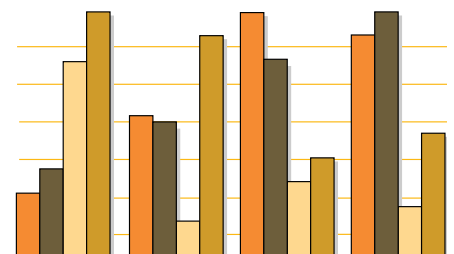

Cutting edges (bolt-on or weld-on)

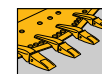

Flushmount adapters

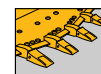

Bottom-strap adapters

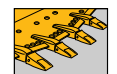

Two-strap adapters

- Penetration ability
- Impact resistance
- Wear life/Abrasion protection
- Smooth floor maintenance

Work Tools and Quick Couplers

Add versatility to your machine with a wide range of special buckets and quick couplers designed for the 950G to optimize your operation.

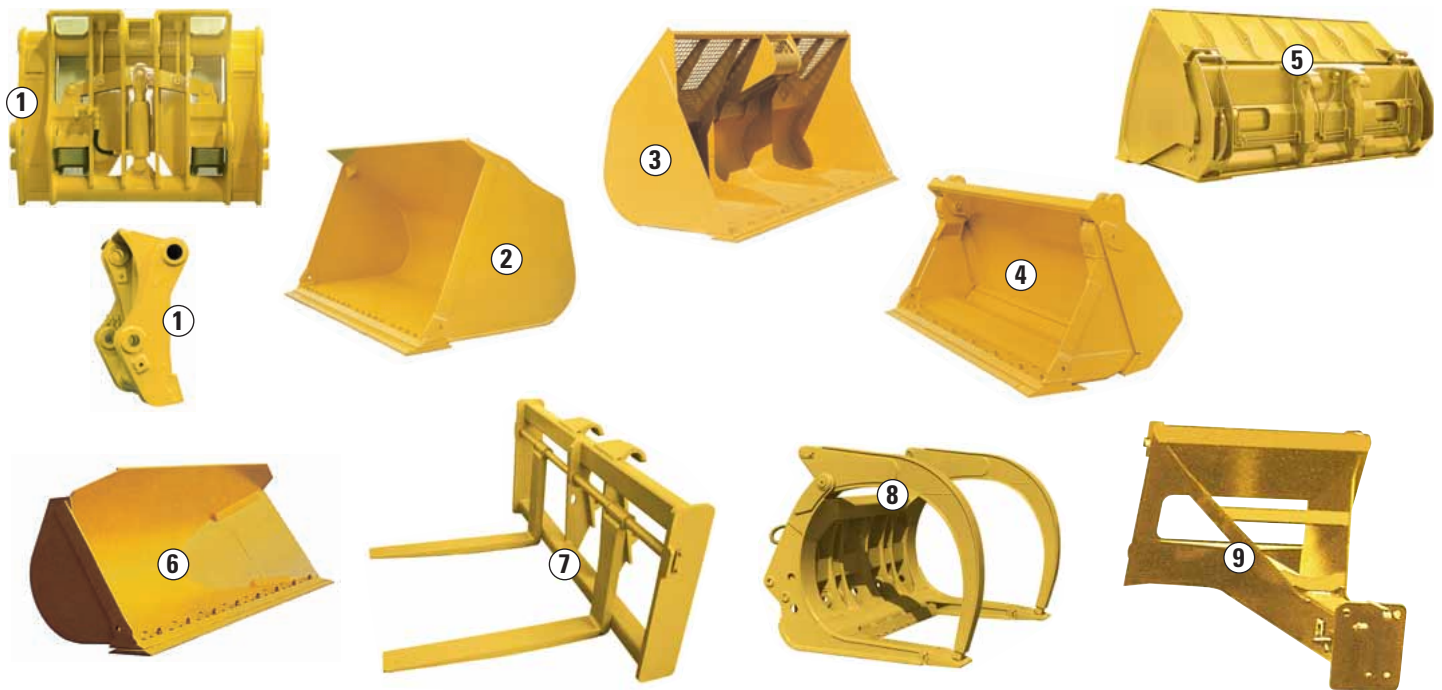

1 Quick couplers provide unmatched versatility and allows one operator with one machine to perform a wide variety of tasks, resulting in greater machine performance and cost efficiency. Use the dedicated quick coupler actuation circuit (optional) to activate the quick coupler and change mechanical tools without leaving the cab. Having a dedicated circuit also leaves the third valve solely to actuate hydraulic tools without the need for diverter valves. The benefits of the vertical wedgelock quick coupler are:

- Minimal loss of break-out force
- Automatic adjustment for wear
- High durability

2 Coal buckets are available in special widths. All coal buckets include a bolt-on cutting edge.

3 Woodchip buckets are specially designed to load and carry woodchips and similar light materials. Bolt-on cutting edges are included as standard. Visibility screens help the operator with loading.

4 Multi-purpose buckets. Loading, dozing, clamping objects or filtering the discharge of material are easy tasks with multi-purpose buckets.

5 High-dump buckets are ideal for applications as various as loading stockpiled, light material into high sided trucks, hoppers in waste transfer stations or rehandling fertilizer, coal or grain.

6 Side-dump buckets permit loaders to operate in congested worksites and also dump forward like conventional buckets.

7 Forks. Pallet forks are the ideal tools for handling a variety of materials.

8 Log fork with top clamp – For tree length or cut to length logs. Lumber and log forks are also available.

9 Material handling arm with adjustable lengths and load capacities, material handling arm provide a boom for placing material from overhead – great for lowering pipes and beams into position on construction projects.

Fertilizer buckets are available and can be designed for different hopper heights, widths and intake capacities. The special design allows fertilizers to spread in the bucket filling in the whole volume.

Brick and clay buckets are ideal for the handling of sticky materials like clay and gypsum. They are fitted with specific linings, featuring low coefficient of friction and good abrasion resistance.

Screening buckets allow operators to scoop, screen, blend, mix and load materials as various as top soil, clay, sand peat, compost, bark, coal, lime, glass bottle... Different screening drums and tool options are available.

Plows. Hydraulic reversible plows angle 30°, left or right. This reversing action is ideal for cleaning applications on mountain roads, airports, parking lots, plant facilities, etc.

A complete range of attachments and tools is available from your Caterpillar dealer.

Serviceability

Keep machines up and running with easy-to-perform daily maintenance.



Maintenance has never been more accessible than on G-Series machines. Fast, easy and reduced maintenance means improved uptime and greater value.

- Lockable, ground level service doors give quick access to engine oil fill and dipstick, coolant sight gauge, air filter indicator, rear grease fittings, and battery disconnect switch. Sight gauges for hydraulic and transmission oil levels are also easily viewable from the ground.
- 295 liter fuel tank provides extra capacity for long work days.
- Grouped remote grease fittings allow ground level access for lubricating tilt and steering cylinder pins and rear axle oscillation bearings.
- Caterpillar fluid filters are especially designed to assure maximum component life. The unique design uses non-metallic centertube and molded end-caps, which fully blend with media ensuring no internal leakage.
- Cat high efficiency fuel filters with STAY CLEAN VALVES™ feature cellulose/synthetic blend media that remove more than 98 percent of particles that are two microns or larger, maximizing fuel injector life.
- Caterpillar Radial Seal air filters do not require tools to service, reducing maintenance time. The ultra-high efficiency primary air filter element is coated with a fine layer of fibers that prevent dust particles from entering the filter media. This results in more efficient filtration, extended service intervals, and extended filter life – all contributing to reduced operating costs.

- Caterpillar Extended Life Coolant allows extended change intervals (6000 hours).
- Caterpillar maintenance-free, high output batteries are designed for high cranking power and maximum protection against vibration.
- Individual Multi-Row Modular core radiator reduces time to repair or replace the radiator.
- G-Series machines feature a new brake wear indicator port.

Reliability and durability

- **Paint Process.** Great care is given to ensure a durable paint finish. Most brackets and other hardware are zinc-plated. Larger components are all prime painted, the cab receiving a zinc-phosphate based coating to prevent rust. The entire machine, as well as decals, is finish painted with a clear, two-component, polyurethane based paint which provides a durable, UV resistant, high gloss.
- **Electrical Systems** on Cat machines are designed and manufactured to resist the most severe conditions. Harnesses are made of large-section, colored and number-coded wires, the complete harness being protected by an abrasion resistant braiding. Connectors are made of rugged thermoplastic or cast-aluminum shells, sealed against moisture and contaminants. Harnesses are properly routed and securely clamped to ensure their reliability and durability.

Sloped hood, electrically or mechanically activated, tilts up for complete access to the engine, cooling system and other major components. If needed, the hood can be removed quickly and easily by removing three pins and disconnecting a single harness connector. A built-in lifting point facilitates easy lift off.

Automatic Greasing System supplies the required quantity of grease at the right interval to the grease points automatically, without manual interference. It greases whilst the machine is in operation, resulting in better distribution of grease over the bearing surface. Also, the automatic greasing reduces downtime, repair and overhaul costs, safety and environmental hazards and greasing costs (up to 75%). The automatic greasing system is optional and being factory installed prior to final assembly.

Caterpillar engine, transmission and hydraulic oils deliver maximum performance and service life.

Factory remanufactured parts.

A large choice of factory remanufactured parts and dealer proposed repair options increases machine availability and reduces repair cost.

Preventive Maintenance

By anticipating potential problems and avoiding unscheduled repairs, your equipment is always up and ready to run.



Caterpillar Monitoring System

Caterpillar Monitoring System (CMS) monitors all key controls and functions. The system alerts the operator of immediate or impending problems with engine oil pressure, brake oil pressure, parking brake, electrical charging system, low fuel level, hydraulic oil level, hydraulic filter and primary and secondary (if equipped) steering. In the service mode, the digital panel displays operating parameters, diagnostic codes and out-of-range gauge readings. It also calibrates the electronic lift and tilt controls as well as the electronic transmission controls. More than 90 fault codes are already visible on the CMS screen in the cab. They are documented in the Operation and Maintenance Manual of the machine allowing you to identify directly where the potential defect has occurred.

- 1 ET software
- 2 Communications Adapter
- 3 Diagnostic Connector
- 4 Electronic Control Modul (ECM)

Electronic Technician

Caterpillar Electronic Technician (ET) is a software program which allows the service technician to find and identify a problem on a machine and to analyze how to fix it quickly. ET provides him with the capability to access the Electronic Control Modules from a personal computer.

The Electronic Technician is used for:

- Viewing active and non active diagnostic codes and clearing them after repair.
- Displaying the status of all parameters such as engine speed, gear engaged, control levers position, control switch position, etc.
- Performing diagnostic test and calibrations of electro-hydraulic components.
- Viewing current configuration and changing parameter settings.
- Flashing new Caterpillar softwares in the Electronic Control Modules.
- Recording all parameters during machine operation.

A customer version of ET is also available for your fleet of Caterpillar equipment. Contact your Caterpillar dealer for more detailed information.

Scheduled Oil Sampling (S•O•S) analysis

Caterpillar has specially developed S•O•S. to help ensure better performance, longer life and increased customer satisfaction. It is an extremely thorough and reliable early warning system which detects traces of metals, dirt and other contaminants in your engine, axle, transmission and hydraulic oil. It can predict potential trouble early, thus avoiding costly unscheduled failures. Your Caterpillar dealer can give you results and specific recommendations shortly after receiving your sample.

Each S•O•S test can provide specific types of diagnostic:

- **Oil condition analysis** identifies loss of lubricating properties by quantifying combustion products such as soot, sulfur, oxidation and nitrates.
- **Wear analysis** monitors components wear by detecting, identifying and assessing the amount and type of metal wear elements found in the oil.
- **Chemical and physical test** detect the physical presence of unwanted fluids (water, fuel, antifreeze).

3126 DITA Engine

Four-stroke cycle, six-cylinder 3126 direct injected, turbocharged and aftercooled diesel engine.

Ratings

	kW	hp
Maximum flywheel power at 1650 rpm	147	197

The following ratings apply at 2200 rpm when tested under the specified standard conditions:

Rated flywheel power	kW	hp
ISO 9249	137	183
EEC 80/1269	137	183

Maximum flywheel torque at 1400 rpm	929 Nm
-------------------------------------	--------

Total torque rise	57%
-------------------	-----

Dimensions

Bore	110 mm
------	--------

Stroke	127 mm
--------	--------

Displacement	7.2 liters
--------------	------------

Exhaust emissions

The 3126 meets the following emissions requirements:

- EU (97/68/EC standard)
- US EPA
- Japan MOC

Power rating conditions

- net power advertised is the power available when the engine is equipped with hydraulic fan drive, alternator, air cleaner, and muffler
- no derating required up to 2300 m altitude

Features

- direct-injection fuel system with individual adjustment-free unit injectors for cylinders
- water jacket aftercooled
- aluminum-alloy skirt and steel crown, 3-ring, 2-piece articulated pistons, cam-ground, tapered and cooled by oil spray
- Chrome Ceramic Surface (CCS) top ring, designed for high load/high temperature application
- induction-hardened, forged crankshaft
- uniflow cylinder head design with two alloy-steel valves per cylinder
- deep-skirted cast cylinder block
- tapered connecting rods
- oscillating roller-followers
- direct-electric 24-volt starting and charging system with two 12-volt, CCA: 750BCI, 475 DIN Caterpillar maintenance-free batteries, heavy-duty starter and a 70-amp
- multi-row radiator
- air intake heater available
- Electric Fuel Priming pump

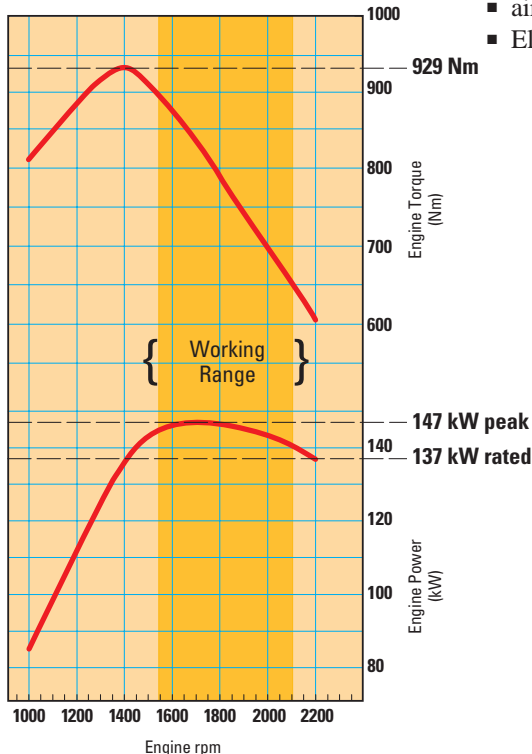

High Torque Rise

The direct injected fuel system delivers a controlled increase of fuel as the engine lugs back from rated speed. This results in horsepower greater than rated power. The combination of increased torque rise and maximum horsepower improves response, provides greater rimpull, more lift force and faster cycle times. The 147 kW (197 hp) maximum power occurs at 1650 rpm when power is needed during the working cycle.

Electronic Transmission

Electronic planetary transmission with automatic shift capability has four speeds forward and four reverse.

Maximum travel speeds (standard 23.5-R25, L-3, tires)

Forward	km/h
1	6.9
2	12.7
3	22.3
4	37.0

Reverse	km/h
1	7.4
2	13.7
3	24.0
4	39.5

Features

- single control for both speed and direction selections
- quick gear quick down button
- automatic shift capability
- single-stage, single-phase torque converter
- F-37 high energy friction material provides long clutch life
- high contact ratio gears are precision ground for quieter operation
- Electronic Clutch Pressure Control (ECPC) modulates clutches engagement
- externally mounted electro-hydraulic valves with quick disconnect pressure ports for easy diagnostic checks
- transmission can be recalibrated and monitored using Electronic Technician (ET) service tool
- Variable Shift Control (standard) controlling the selected shift pattern.

Axles

Fixed front, oscillating rear ($\pm 13^\circ$).*

Features

- maximum single-wheel rise and fall: 470 mm
- differentials, enclosed brakes and final drives included
- conventional differentials are standard; limited slip differentials are optional
- bronze sleeve bearings in the planet gears; bronze spherical thrust washers on differential pinions
- patented Duo-Cone seals between axle shaft and housing
- uses SAE 30W (oil change interval: 2000 hours or one year)
- axle oil temperature sensors

* Oscillating may have to be reduced when using L5 tires, chains or oversized tires.

Brakes

Meet the following standard: ISO 3450-1996.

Service brake features

- full-hydraulic actuated, oil-disc brakes
- completely enclosed and sealed
- self adjusting, modulated engagement
- separate circuits for front and rear axles with dedicated piston-type accumulators to ensure dead engine braking
- dual pedal braking system, left-hand brake pedal also integrates a transmission neutralizer and a downshift logic
- external ports provide access to measure brake disc wear.

Parking brake features

- spring applied, hydraulically actuated, dry drum
- mounted on transmission output

Final Drives

Planetary final drives consist of ring gears and planetary carrier assemblies.

Features

- ring gears are pressed in and doweled to axle housings
- carrier assemblies include:
 - planet gears with full-floating bronze sleeve bearings
 - planet shafts
 - retaining pins
 - bearings
 - sun gear shafts
 - planetary carriers

Hydraulic System

Open-centered, interrupted series system with full-flow filtering. System is completely sealed.

Implement system, vane-type pump

Output at 2200 rpm and 6900 kPa with SAE 10W oil at 66°C	292 liters/min
Relief valve setting	20 700 kPa
Cylinders, double acting	
lift, bore and stroke	152.4 x 800 mm
tilt, bore and stroke	177.8 x 540 mm

Pilot system, vane-type pump

Output at 2200 rpm and 6900 kPa with SAE 10W oil at 66°C	34 liters/min
Working pressure	
pilot	2585 kPa
E/H	3450 kPa

Hydraulic cycle time	seconds
Raise	6.3
Dump	2.2
Lower, empty, float down	2.2
Total	10.7

Features

- completely enclosed system
- full-flow filtering
- reusable couplings with O-ring face seals
- pilot shutoff valve on Conventional steering or electrical lockout switch on Command Control steering disable implement functions
- hinged hydraulic oil cooler is standard
- Caterpillar's XT hoses
- pressure taps for all hydraulic circuits
- automatic Ride Control System is available as an attachment
- Cat biodegradable oil available

Cab

Caterpillar cab and Rollover Protective Structure (ROPS) are standard.

Features

- ROPS meets the following criteria:
 - ISO 3471:1994
- also meets the following criteria for Falling Objects Protective Structure:
 - ISO 3449:1992 LEVEL II
- corrosion-free roof cap

Implement Controls

Lift circuit features

- four positions: raise, hold, lower and float
- mechanically adjustable lift height with automatic kickout on conventional steering configuration
- in-cab, programmable high and low lift kickouts with cushioned stops on Command Control steering configuration

Tilt circuit features

- three positions: tilt back, hold and dump
- one mechanically adjustable kickout for bucket load position

Controls

- two lever control (standard)
- three lever control (optional)
- joy stick (optional on the conventional steering configuration) combines lift and tilt controls

Load Sensing Steering

Full hydraulic power steering.
Meets ISO 5010:1992

Ratings

Minimum turning radius (over tire)	6027 mm
Machine articulation angle, each direction	40°
On Command Control steering, steering wheel angle, from stop to stop	140°
On Conventional steering, steering wheel turns, from stop to stop	3.2 x 360°
Hydraulic output at 2280 rpm and 7000 kPa	160 liters/min
Relief valve setting	19 980 kPa

Features

- center-point frame articulation
- front and rear wheels track
- load sensing hydraulic steering pump
- flow-amplified, closed-center, pressure-compensated system
- full-flow filtering

Service Refill Capacities

	Liters
Fuel tank	295
Cooling system	49
Crankcase	30
Transmission	34
Differentials and final drives	
Front	36
Rear	36
Hydraulic system (including tank)	153
Hydraulic tank	88

Sound Levels/Dynamics

Operator sound	dB(A)
Standard sound suppression ⁽¹⁾	75
Low sound ⁽²⁾	73
Blue Angel ⁽³⁾	72
Exterior sound	
Standard sound suppression ⁽¹⁾	109
Low sound ⁽²⁾	105
Blue Angel ⁽³⁾	101

⁽¹⁾ The operator sound pressure levels are measured according to the dynamic test procedures and conditions specified in ISO6396. The exterior sound power levels are measured according to the dynamic test procedures and conditions specified in ISO6395 and 95/27/EC.

⁽²⁾ According to EU 2000/C 83/01 requirements.

⁽³⁾ According to RAL-UZ 53:1998

Tires

Tubeless, loader-design tires.

- 23.5-R25 XTLA (L-2)
- 23.5-R25 XHA (L-3)
- 625-R25 XLD70 (L-3T)
- 23.5-R25 XLDD2 (L-5)
- 23.5-R25 XMINED2 (L-5)
- 23.5-R25 GP-2B (L-2/L-3)
- 23.5-R25 RL-2+ (L-3T)
- 23.5-R25 GP-4B (L-4)
- 23.5-R25 RL-5K (L-5)

In certain applications (such as load-and-carry work) the loader's productive capabilities might exceed the tires' tonnes-km/h capabilities. Caterpillar recommends that you consult a tire supplier to evaluate all conditions before selecting a tire model.

Dimensions

All dimensions are approximate

- ◆ Dimensions vary with buckets or tires.
Refer to operating specifications chart on pages 24-25
or to supplemental specifications chart on this page.

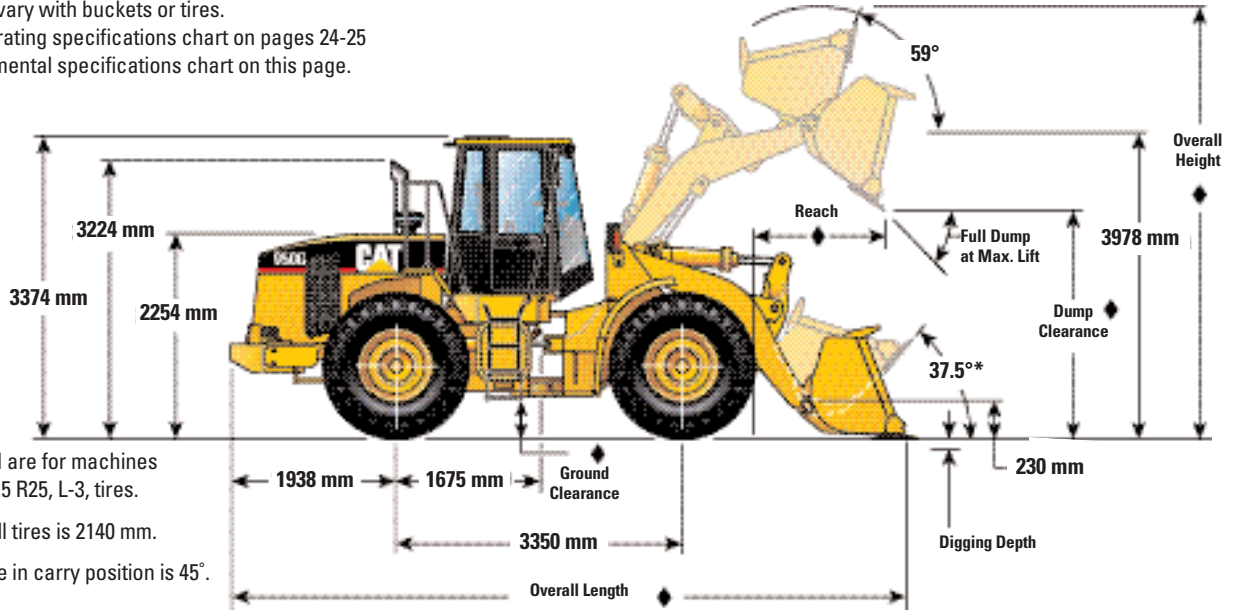

Dimensions listed are for machines equipped with 23.5 R25, L-3, tires.

Tread width for all tires is 2140 mm.

* Rack back angle in carry position is 45°.

Supplemental Specifications

	XHA	XLD70	XLDD2	XMINED2
Tread type	L3	L3T	L5	L5
Dimension	23.5 x R25	625/R25	23.5 x R25	23.5 x R25
Width over tires (mm)	2750	2761	2760	2785
Ground clearance (mm)	405	345	441	464
Change in all vertical dimensions (mm)	Used as reference	-60	+36	+59
Weight variation (kg)	0	-148	+564	+724
Change in static tipping load (kg)				
straight	None	-111	+426	+546
full articulation	None	-99	+375	+482
	GP 2B	RL 2+	GP 4B	RL 5K
Tread type	L2/L3	L3T	L4	L5
Dimension	23.5 x R25	23.5 x R25	23.5 x R25	23.5 x R25
Width over tires (mm)	2760	2763	2774	2771
Ground clearance (mm)	435	433	449	463
Change in all vertical dimensions (mm)	+30	+28	+43	+58
Weight variation (kg)	0	+148	+440	+732
Change in static tipping load (kg)				
straight	None	+112	+332	+552
full articulation	None	+98	+293	+487

Operation Specifications

		Universal Buckets							
		Bolt-on Cutting Edge	Bolt-on adapters, Tips and Segments (no GET)	Bolt-on Cutting Edge	Bolt-on adapters, Tips and Segments (no GET)	Bolt-on Cutting Edge	Bolt-on adapters, Tips and Segments (no GET)	Bolt-on Cutting Edge	Bolt-on adapters, Tips and Segments (no GET)
Rated bucket capacity	m ³	4.0	4.0 (3.8)	3.5	3.5 (3.3)	3.3	3.3 (3.1)	3.1	3.1 (2.9)
Struck capacity	m ³	3.6	3.6 (3.4)	3.1	3.1 (2.9)	2.9	2.9 (2.7)	2.7	2.7 (2.5)
Width	mm	2927	2994	2927	2994	2927	2994	2927	2994
Dump clearance at full lift and 45° discharge (without GET) ⁴	mm	2816	2816	2905	2905	2941	2941	2976	2976
Dump clearance at full lift and 45° discharge (with GET) ⁵	mm	2728	2635	2818	2725	2854	2760	2890	2797
Reach at full lift and 45° discharge ⁵	mm	1301	1391	1213	1303	1178	1268	1143	1233
Reach with lift arms horizontal and bucket level ⁵	mm	2791	2933	2666	2808	2616	2758	2566	2708
Digging depth	mm	101	101	101	101	101	101	101	101
Overall length ⁵	mm	8208	8350	8083	8225	8033	8175	7983	8125
Overall height with bucket at full raise	mm	5369	5369	5281	5281	5248	5248	5215	5215
Loader turning radius with bucket in carry position	mm	6709	6791	6657	6728	6640	6711	6623	6694
Bucket weight	kg	1830	1915 (1597)	1688	1773 (1455)	1630	1715 (1397)	1578	1663 (1345)
Static tipping load straight ¹	kg	11890	11800 (12119)	12030	11940 (12259)	12090	12000 (12319)	12150	12060 (12379)
Static tipping load at 35° articulation ¹	kg	10780	10690 (11009)	10920	10830 (11149)	10980	10890 (11209)	11040	10950 (11269)
Static tipping load at 40° articulation ¹	kg	10450	10360 (10679)	10590	10500 (10819)	10650	10560 (10879)	10710	10620 (10939)
Breakout force ²	kN	131.5	(141.2)	143.8	(155.4)	149.4	(161.9)	155.4	(169.0)
Operating weight ¹	kg	17899	17894 (17666)	17757	17842 (17524)	17699	17784 (17466)	17647	17732 (17414)

¹ Static tipping load and operating weight shown are based on standard machine configuration with sound-suppression cab and ROPS, secondary steering, air conditioning, ride control, 23.5-R25, L-3, tires, full fuel tank, coolant, lubricants, lights, directional signals with CE plates and operator.

² For buckets with adapters, tips and segments, value is measured 102 mm behind the tip of the segment, with bucket hinge pin as pivot point, in accordance with SAE J732C.

³ All buckets shown can be used on the high lift arrangement. High lift column shows changes in specifications from standard lift to high lift. Add or subtract as indicated to or from specifications given for appropriate bucket to calculate high lift specifications.

Dimensions for dump clearance, reach and overall length:

⁴ Measured at bucket base edge, not considering any Ground Engaging Tool.

⁵ Actual dimensions taken at the tip of the Ground Engaging Tools, either the tip of the bolt-on cutting edge or the tip of the teeth, type long.

	General Excavation Buckets						Rock Buckets		High Lift ³
	Bolt-on Cutting Edge	Bolt-on adapters, Tips and Segments (no GET)	Bolt-on Cutting Edge	Bolt-on adapters, Tips and Segments (no GET)	Bolt-on Cutting Edge	Bolt-on adapters, Tips and Segments (no GET)	Bolt-on Cutting Edge	Bolt-on adapters, Tips and Segments (no GET)	
	3.1	3.1 (2.9)	2.9	2.9 (2.7)	2.7	2.7 (2.5)	2.9	2.9 (2.7)	same
	2.7	2.7 (2.5)	2.5	2.5 (2.3)	2.3	2.3 (2.1)	2.6	2.6 (2.4)	same
	2927	2994	2927	2994	2927	2994	2984	2969	same
	2945	2945	2987	2987	3028	3028	2898	2898	+518
	2859	2767	2902	2810	2944	2852	2811	2717	+518
	1189	1279	1146	1236	1103	1193	1222	1312	+27
	2631	2773	2571	2713	2511	2653	2674	2816	+372
	101	101	101	101	101	101	101	120	-11
	8048	8190	7988	8130	7928	8070	8087	8229	+442
	5257	5257	5198	5198	5140	5140	5330	5330	+551
	6644	6715	6627	6698	6610	6681	6697	6768	+357
	1699	1784 (1466)	1630	1715 (1397)	1568	1653 (1335)	2034	2136 (1824)	-
	11950	11860 (12179)	12000	11910 (12229)	12050	11960 (12279)	11620	11530 (11848)	-1570
	10830	10740 (11059)	10880	10790 (11109)	10930	10840 (11159)	10460	10390 (10688)	-1470
	10490	10400 (10719)	10540	10450 (10769)	10590	10500 (10819)	10110	10040 (10338)	-1430
	147.6	(159.9)	154.8	(168.3)	162.6	(177.6)	142.7	(154.1)	-5.4
	17768	17853 (17535)	17699	17784 (17466)	17637	17722 (17404)	18103	18205 (17893)	+509

Bucket Selection Guide

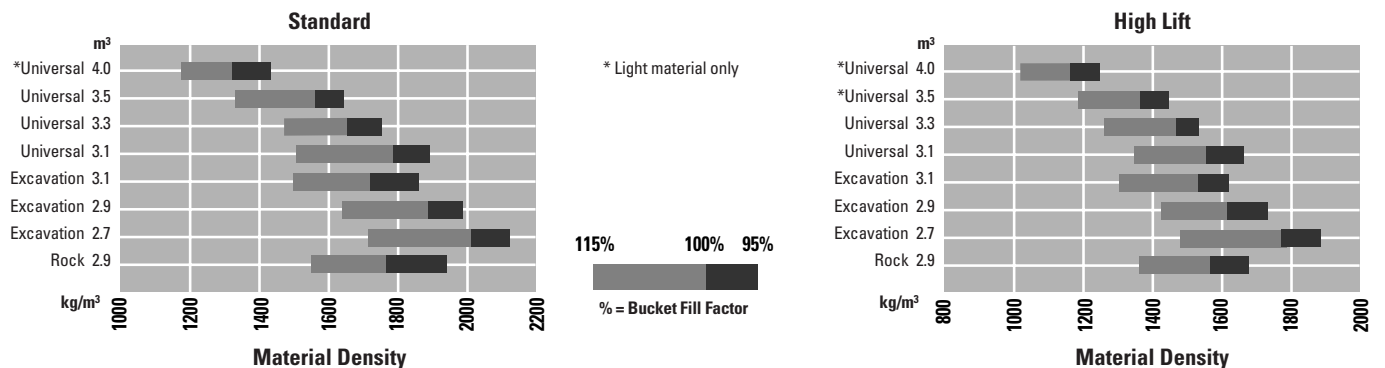

Standard Equipment

Standard equipment may vary. Consult your Caterpillar dealer for specifics.

Electrical

70-amp alternator
Batteries (two 12-volt, maintenance free,
CCA: 750 BCI, 475 DIN)
Ignition key start/stop switch
Main disconnect switch
Light directional signals**
Starter, electric, heavy duty (24-volt)
Voltage converter (12-volt, 5 amp)
Diagnostic connector
Working halogen lighting system,
including six lights:
Two forward floodlights on
the loader tower
Two forward floodlights on the cab
Two rearward floodlights on
the counterweight

Starting Aid

Air intake heater**

Operator Environment

Adjustable steering column
Air conditioning (R134a refrigerant)**
Air recirculation filter
Conventional steering version:
Seat with mechanical suspension,
adjustable backrest, armrest and
lumbar support
Lockable compartment for
personal items
Pilot hydraulic implement controls,
lift and tilt
Hydraulic lift and tilt lock lever
Command Control steering version:
Caterpillar Contour Series seat, 6-way
adjustable, with air suspension
Electro-hydraulic implement controls,
lift and tilt
Programmable and cushioned lift
kickouts, high and low
Hydraulic lift and tilt lock switch
Cab, pressurized with sound suppression
and rollover protective structure (ROPS)
Cab dome lights*
Heater and defroster*
Horn, electric, steering wheel mounted
Cigar lighter and ashtray
Coat hook
Cup and thermos holders
Mirrors, rearview, outside mounted
Radio ready cab*
Seat belt, retractable, 76 mm wide
Tinted glass

Electronic monitoring system:

3-category alarm system

Gauges:

Speedometer
Tachometer
Fuel level
Hydraulic oil temperature
Transmission oil temperature
Engine coolant temperature

Warning indicators:

Engine oil pressure
Parking brake
Brake oil pressure
Brake oil temperature
Charging system
Inlet air heater status**
Hydraulic oil level
Hydraulic filter bypass
Primary steering oil pressure
Secondary steering oil pressure*/**

Windshield washers/wipers, wet arm,
front and rear, front intermittent*

Engine

Air precleaner, Radial Seal filters,
primary (Ultra High Efficiency)
and secondary
Cat 3126 diesel engine, direct injection,
turbocharged with waste-gate valve
and water jacket aftercooler
Cooling system:
Multi-row modular radiator
On demand radiator cooling fan,
hydraulically driven
Hydraulic oil cooler
Air conditioner condenser*/**
Fuel system:
Priming pump, electric
Pre-filter and water separator
Series filters, 2-micron
Sound suppressed muffler

Drive Train

Torque converter
Transmission, planetary, power
shift, 4F/4R:
Electronic Clutch Pressure Control
Automatic shift capability
Fully automatic speed range control
Direction and gear selection switch with
quick gear kickdown button
Transmission auto/manual switch
Transmission neutralizer on/off switch
Brakes, full-hydraulic actuated,
enclosed wet discs
Differential limited slip, rear axle**
Integrated Braking System
Variable Shift Control

Hydraulics

Automatic bucket positioner
Automatic Ride Control System*/**
Caterpillar O-ring face seals couplings
Caterpillar XT hoses
Loader linkage, sealed Z-bar design
Steering, load-sensing hydraulic
Secondary steering**

Preventive Maintenance

Caterpillar diesel engine oil
Caterpillar transmission oil
Caterpillar hydraulic oil
Caterpillar High Efficiency fuel filters
Caterpillar Ultra High Efficiency,
Radial Seal primary air filter
Caterpillar Radial Seal secondary
air filter
Extended Life Coolant
antifreeze (-30°C)
Hydraulic pressure taps
(diagnostic connectors)
Scheduled Oil Sampling (S•O•S) valves
Service indicators:
Air cleaner sight gauge
Coolant level sight gauge
Hydraulic oil level sight gauge
Transmission oil level sight gauge

Other Standard Equipment

Counterweight, single section
Crankcase guard*/**
Dedicated quick coupler actuation
circuit
Drawbar hitch with pin
Engine enclosure, tilting, electrically
actuated, non-metallic, one-piece
Fenders, front, with mud flaps
Locking engine enclosures
Platform deflectors for rear wheels
Powertrain guard*/**
Vandalism protection, caplocks*/**

* Not included in Open Cab configuration

** May be optional in some countries

Optional Equipment

Optional equipment may vary. Consult your Caterpillar dealer for specifics.

Electrical

Auxiliary halogen lighting package including

- Two additional forward floodlights on the cab

- Two rearward floodlights on the cab

Back up alarm

Roading light package, including turning signals, high/low beams and associated switch

Warning lighting system, rotating beacon

Starting Aid

Engine block heater, 240-volt

Ether starting aid (-26°C)

Operator Environment

On the Conventional steering version, Caterpillar Contour Series seat,

- 6-way adjustable, with air suspension

Rearview mirrors, interior

Drive Train

Differential Limited Slip, front axle

Differential No SPIN, rear axle

Hydraulic

Hydraulic arrangement, third valve

Hydraulic oil cooling package, high ambient

Preventive Maintenance

Automatic central lubrication system (factory installed)

Extended Life Coolant antifreeze (-35 to -50°C)

Cat Turbine PreCleaner

Environmental Attachments

Sound levels

- Low sound version, at 105 dB(A) exterior and 73 dB(A) operator

- Blue Angel at 101 dB(A) exterior and 72 dB(A) operator

Cat Bio Hydo (HEES), biodegradable hydraulic synthetic ester based oil

Ecology drain, axle

Other Optional Attachments

Attachments (see page 17)

Buckets (see pages 14-15)

Dedicated quick coupler actuation circuit

High Lift arrangement

High Lift arrangement with hydraulic third valve

Open cab, including ROPS structure (for conventional steering only)

Payload Control System

Rear full coverage roading fenders, swingable, non-metallic

Field Installed Attachments

Field kit, High Lift arrangement

Field kit, hydraulic third valve

Kit, Variable Shift Control

Printer kit for the Payload Control System

Anti-Corrosion Arrangement

providing extensive protection to vital machine components and other surfaces in harsh corrosive applications.

Logger Arrangement

keeping your millyard operation efficient and productive at every stage.

Waste Handling Arrangement

providing extensive guarding and machine modifications (e.g. trash grill), yet allowing easy access for cleaning and maintenance.

Airborne Debris Cooling system

950G Wheel Loader

HEHL5191-3 (03/2001) hr

Materials and specifications are subject to change without notice.
Featured machines in photos may include additional equipment.
See your Caterpillar dealer for available options.

www.CAT.com
© 2000 Caterpillar

CATERPILLAR[®]