

980G

Wheel Loader



Cat® 3406C DITA diesel engine

Rated flywheel power 224 kW/300 hp

Maximum flywheel power 239 kW/321 hp

Bucket capacities 3.8 to 5.7 m³

Operating weight 29 519 kg

980G Wheel Loader

A new standard for wheel loader productivity, serviceability and styling.

Engine

- ✓ The turbocharged and *aftercooled* 3406C delivers increased power due to high torque rise and low parasitic loads for performance operators can really feel.
- ✓ A new temperature sensing on-demand fan slows fan speed when temperatures are low – increasing available power. Lower fan speeds, direct injection, and four-stroke design provide unmatched fuel efficiency and contribute to lower sound levels. This engine meets all current worldwide emissions standards. **pg. 4**

Hydraulics and Operator Controls

- ✓ Enhanced, low-effort operator controls for steering, shifting and bucket loading precisely respond to operator input. Operator controls are configured with Command Control steering with stick on the wheel and electro-hydraulic implement controls. **pg. 8-9**

Performance and comfort you can feel.

Caterpillar design delivers excellent breakout force, fast load and cycle times, precise maneuvering and smoother shifts for optimal performance and comfort.

Unmatched operator comfort and efficiency.

New, World Class cab provides revolutionary electronics and hydraulics for low-effort operation and increased productivity.

Electronic Transmission

- Designed for durability, the Caterpillar® power shift transmission features a full match, high capacity torque converter and heavy-duty planetary drives. Electronic controls provide increased levels of productivity. Stronger transmission, final drives and differentials plus improved brakes for added operating durability.
- ✓ Variable Shift Control (standard) allows the operator to match the shift pattern to the application, improving operator comfort and fuel efficiency. The Integrated Braking System (standard) integrates a downshifting and neutralizer logic into the left-hand brake pedal. **pg. 5**

Operator Station

Ergonomically engineered using advanced virtual reality technology to provide the operator unparalleled comfort, spaciousness and viewing area. Control levers and gauges are ergonomically positioned to maximize productivity. **pg. 10-11**

Axles and Frame

The articulated frame design features a durable box-section engine frame and a rigid four-plate loader tower. Redesigned hitch plates provide less deflection in the articulated joint. Lift arm and linkage geometry provides increased dump clearance and lift capacity. **pg. 6-7**



✓ New features

- Improved Command Control Steering with stick on wheel
- Standard low sound version – 75/107 dB(A)
- Horsepower increased by 20 hp (on-demand fan)
- Variable Shift Control (standard)
- Integrated Braking System (standard)

Versatility

The 980G performs well in a variety of applications such as bank material, aggregates, construction and heavy utility work. With an increased standard dump clearance and more power, there's less need for a high lift option to load off-highway trucks. Special arrangements are available.
pg. 12

Application Match

Matched payload and matched buckets ensure optimum performance.
pg. 13

Buckets and Ground Engaging Tools

Choose from three bucket families, General Excavation, Rock V-edge and the newly designed Universal, combined with a large variety of Ground Engaging Tool options to allow precise application match. **pg. 14-16**

Environmental Machine

- ✓ *Quieter operation with the standard low sound version – 75/107 dB(A) operator and exterior sound – combined with easy serviceability help you meet or exceed worldwide regulations and protect the environment.*
pg. 17

Serviceability

Easily perform daily maintenance with ground-level access to major service points such as oil levels and fills, grease fittings, sight gauges, filters and electrical breakers. A diagnostic connector allows quick electronic analysis. The tilting hood provides unmatched access for larger maintenance jobs. **pg. 18**

Preventive Maintenance

- ✓ *Thanks to the Caterpillar Monitoring System, the Electronic Technician and the Scheduled Oil Sampling analysis, you can anticipate potential problems and avoid unscheduled repairs.*
pg. 19



3406C DITA Engine

The six-cylinder, direct injection, turbocharged and aftercooled (DITA) engine is built for power, reliability, low maintenance, excellent fuel economy and low emissions.

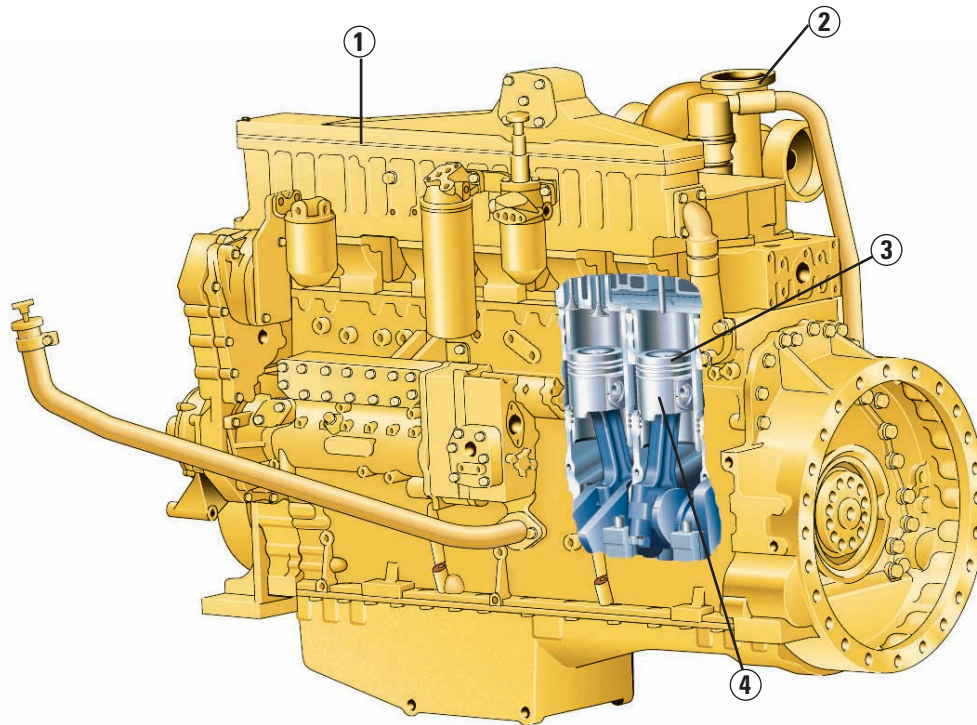

Caterpillar 3406C DITA engine

The six-cylinder, turbocharged and aftercooled 3406C engine is one of the most developed and proven engines offered by Caterpillar. It has a strong reputation for reliability, durability and performance. Thanks to redesigned pistons, cylinder head, turbo and aftercooler, it's now cleaner running too.

- The 3406C delivers a rated flywheel power of 224 kW (300 hp) and a maximum flywheel power of 239 kW (321 hp). High torque rise delivers performance you can feel. The result is more rimpull, greater lift force and faster cycle times.
- The four-stroke engine delivers fuel economy, durability and reliability in the most demanding conditions. Improved intake and combustion chamber designs help reduce emission levels.
- Resilient engine mounts dampen vibration for lower sound levels.

Cooling system features an on-demand, hydraulically driven fan for less radiator plugging, lower noise levels and reduced fuel consumption (by 3% to 5% or more). This results from a lower average fan speed, which depends on the coolant temperature.

- 1 Jacket water aftercooler** reduces smoke and emissions by providing a cooler, more efficient combustion. This also extends the life of the piston rings and bore.
- 2 Turbocharger** enhances performance and engine efficiency, especially at high altitudes by packing more air in the cylinders for excellent combustion.
- 3 Full-length water cooled cylinder liners** provide maximum heat transfer.
- 4 Oil-cooled pistons** increase heat dissipation and promote longer piston life.

Electronic Transmission

Caterpillar power train makes dependable performance a standard feature.

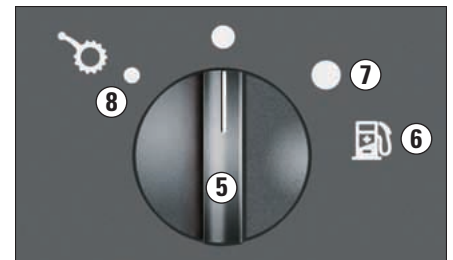
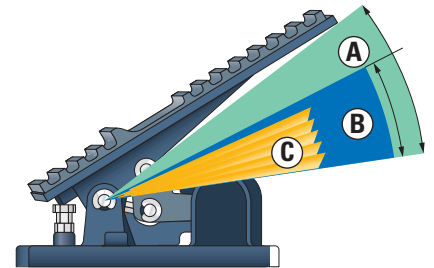
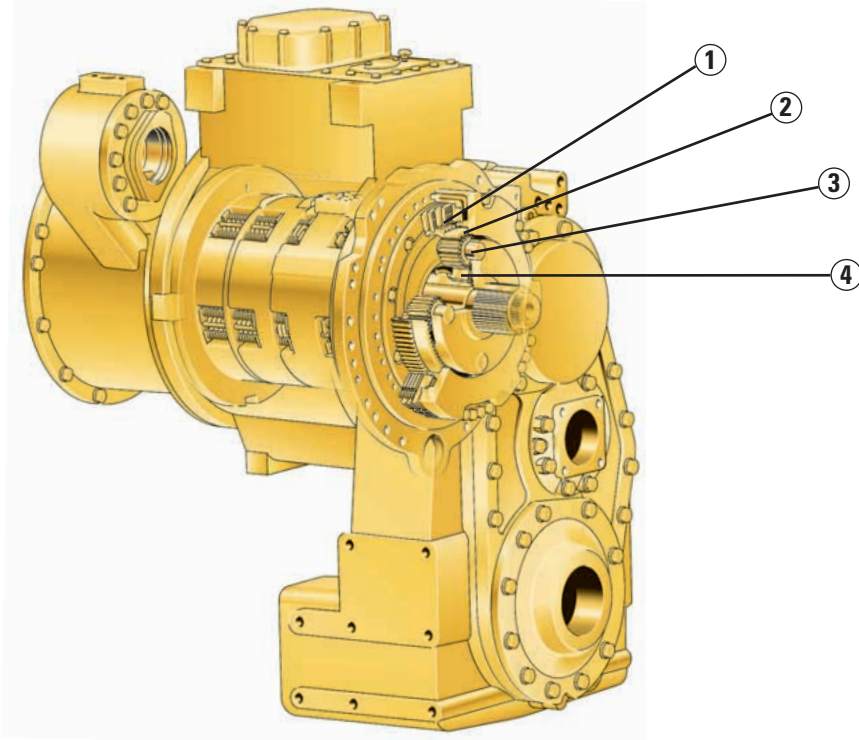

Transmission. The Caterpillar planetary, power shift transmission features heavy duty components to handle the toughest jobs. Electronic controls provide features to enhance productivity, durability and serviceability.

- A heavy duty transmission with 432 mm extreme service four planet drive in first gear and 345 mm heavy duty four planet drives in 2-4 gears, is now standard. The torque converter uses a high-capacity impeller to handle the engine's increased power.
- The flywheel interface uses a long spline oil dam, and the pump drive and output transfer use high contact gear ratios to reduce sound levels.
- Perimeter-mounted, large diameter clutch packs control inertia for smooth shifting and increased component life.
- Electronic Autoshift transmission increases operator efficiencies and optimizes machine performance. The operator can choose between manual or autoshift modes. And, by using the left brake pedal, the operator can engage the adjustable neutralizer, maintaining high engine rpm for full hydraulic flow.

1 Clutch packs

2 Ring gear

3 Planet gears

4 Sun gear

The Integrated Braking System

(standard) integrates a downshifting and neutralizer logic into the left-hand brake pedal. This system translates into increased performance/productivity for the operator thanks to the optimized transmission neutralizer, the automatic downshifting and downhill retarding feature. The Integrated Braking System also lowers the owning and operating costs thanks to reduced axle oil temperatures, which can extend the brake life.

A Downshift logic only

B Brake application initiated

C Self-adjusting transmission neutralization

5 Variable Shift Control (standard)

is a new transmission software which allows the operator to select three different shift patterns based on his application and operating preference. This feature reduces fuel consumption by 2% to 6% or more, depending on the application. In all modes, the full machine power remains available for loading.

6 ISO symbol for fuel efficiency

7 Economy mode (typically used for load and carry and roading applications)

8 Standard mode (typically used for tight truck loading applications)

Transmission neutralizer allows the operator to disengage the transmission clutches, removing torque from the drive train. With the neutralizer, high engine rpm's are maintained for full hydraulic flow and brake drive through is prevented. Adjusting the neutralizer for a given application improves machine inching control, reduces brake energy, and improves fuel efficiency.

Axles

Large, heavy-duty axles protect internal components from the harsh environment and offer excellent serviceability.

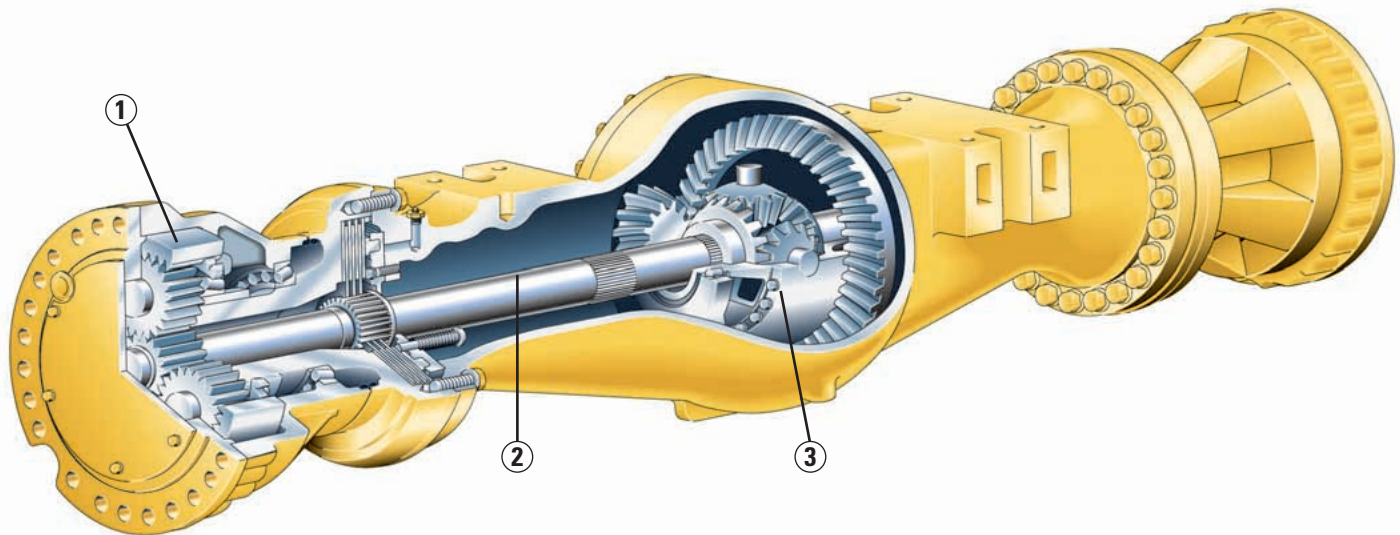

Axles

Heavy duty axles feature stronger gears and bearings in both the differentials and final drives for increased durability. Permanently lubricated maintenance-free U-joints and redesigned final drives result in fewer parts and improved serviceability.

- Larger, shot peened gears and increased bolt capacity improve the durability of the standard differentials. Axle shafts are stronger and feature more splines to help spread the load.
- Redesigned spindles and final drives reduce the number of parts and greatly improve serviceability, allowing easier access to the Duo-Cone Seals without removing the center housing from the machine.
- Optional front and rear limited slip differentials provide maximum traction in poor underfoot or uneven floor conditions by diverting torque to wheels with better traction.

Brakes

Oil-enclosed, multiple-disc brakes feature fewer parts, better heat rejection and improved serviceability. Fully hydraulic actuator circuits improve performance and reliability.

- Brakes operate on the low torque side of the axle requiring less force, resulting in less heat buildup. Improved axle oil circulation provides additional cooling to the brake discs. A combination of thicker reaction plates and improved cooling help improve durability.
- Fewer parts and the location of the brake discs improve serviceability by allowing technicians to remove the spindle, final drive and brake pack as one unit.
- Independent front and rear circuits use separate dead engine braking accumulators, new valves and internal brake lines for increased reliability and performance.

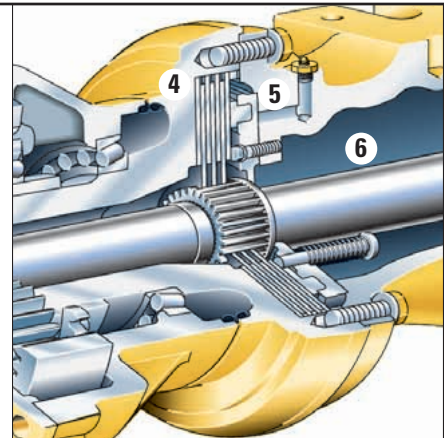

1 Final drives

2 Axle shafts

3 Differential

4 Oil-cooled disc

5 Hydraulic piston

6 Increased brake oil flow

Structures

Built with strength to handle severe loads and durability to provide years of service.

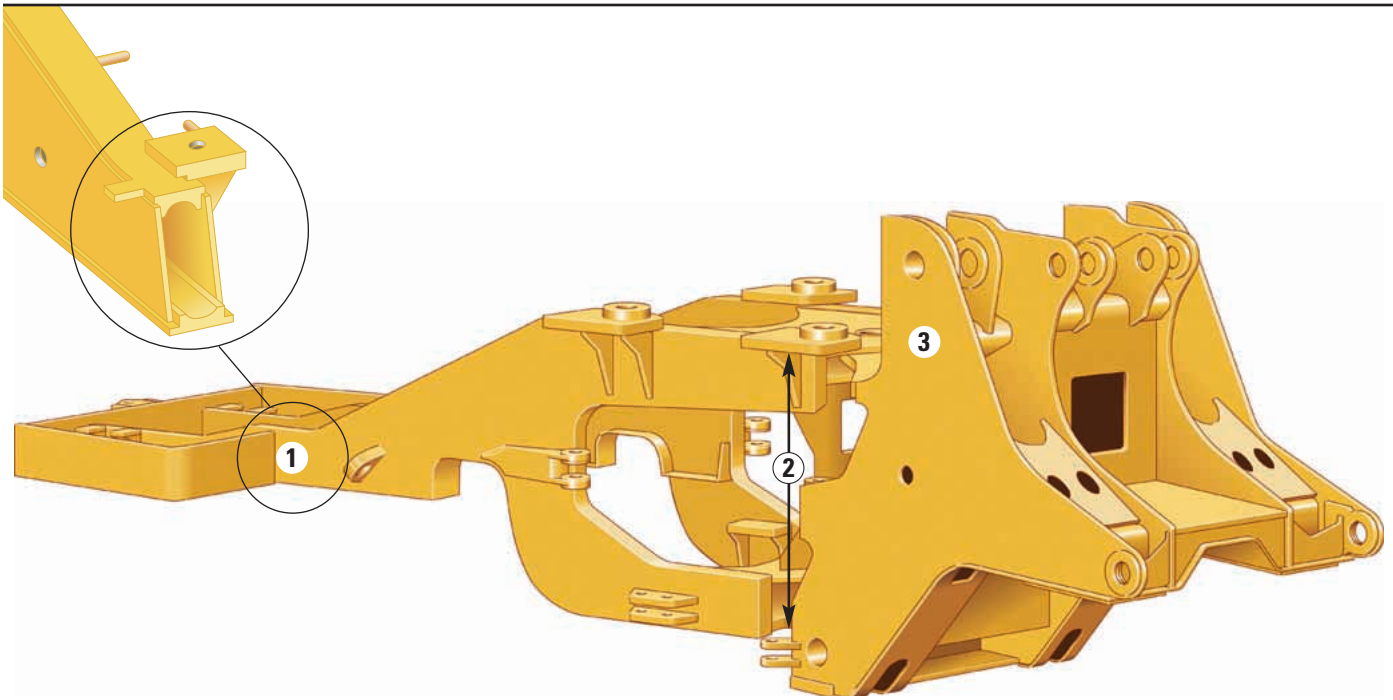

Caterpillar uses advanced processes to design and build superior structures. Robotic welding produces higher quality, deeper penetrating welds for more durable frames, lift arms and linkages.

- 1 Full box-section frame** resists twisting and impact forces to provide a solid foundation for the engine, transmission and axles.
- 2 Spread-hitch design** widens the distance between upper and lower hitch plates to distribute forces and increase bearing life. Thicker hitch plates and butterfly supports reduce deflection. The wide opening also provides good service access.
- 3 Four-plate loader tower** provides a solid mount for lift arms, lift cylinders and Z-bar tilt lever. This structure is built to absorb severe twisting, impact and loading forces.
- 4 Upper and lower hitch pins** pivot on double-tapered roller bearings. This design distributes vertical and horizontal loads over a greater surface area.

Solid steel lift arms provide superior strength with great visibility to the front end. The new design offers increased dump clearance and longer reach for more productivity.

Heat treated, cast-steel cross tube provides excellent resistance to torsion and impact loads, keeping pin bores well aligned.

Z-bar linkage generates powerful breakout forces and a good rack back angle for better bucket loading and material retention.

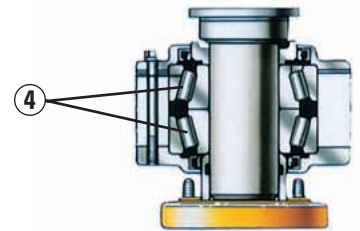

Hydraulics

Well balanced hydraulics deliver precise low-effort control and trouble-free operation.

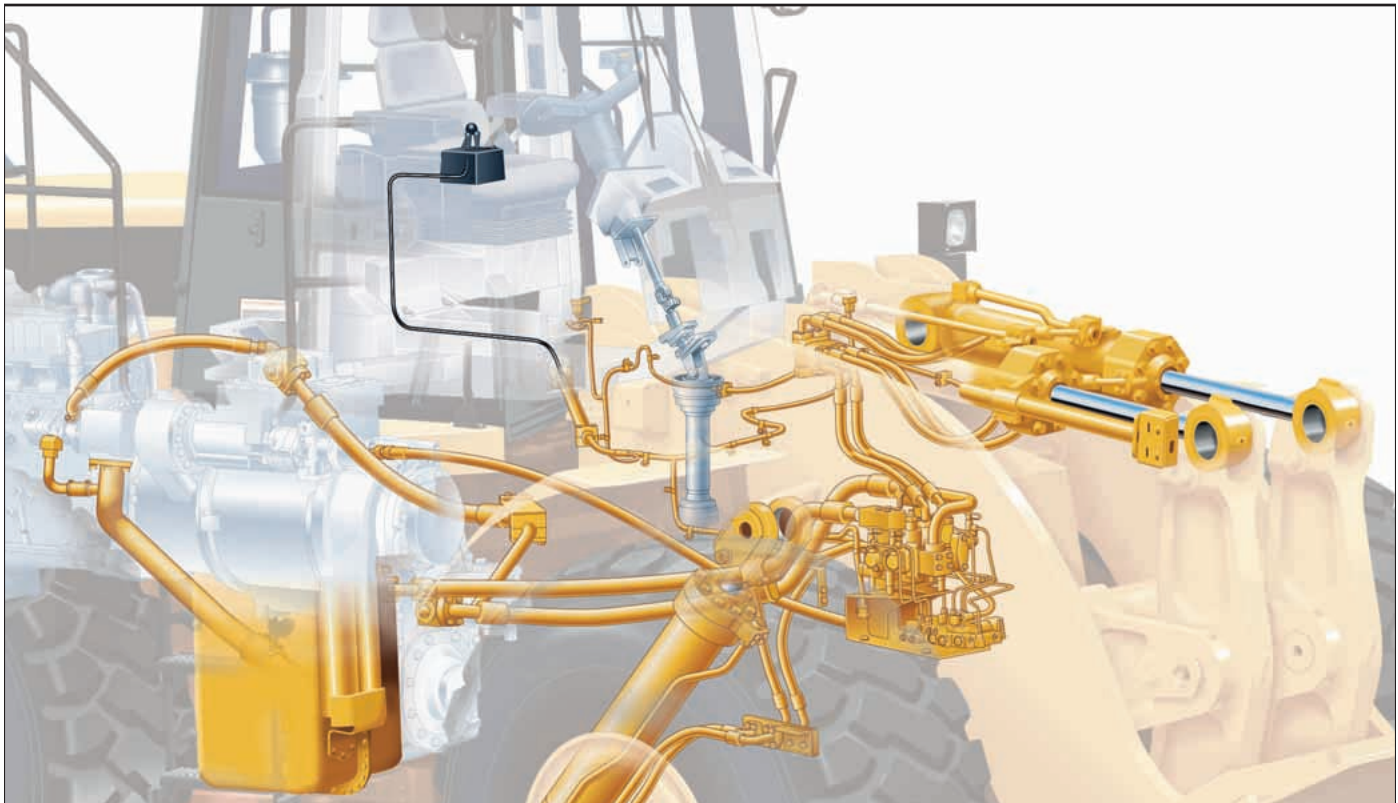

Revolutionary hydraulic system

provide low-effort, finger-tip implement control. Armrest-mounted levers send electrical signals to a pilot valve mounted on the loader frame. This moves the noise, heat and effort caused by a hydraulic valve out of the operator's station.

Low-effort, command control steering

is another result of innovative design. A new mechanical feedback system and a redesigned valve ratio provide quarter-turn side-to-side steering. Unlike systems that rely on steering wheel velocity to activate steering cylinders, this system directly links steering wheel position to articulation angle. The benefit is precise control, quicker response and dramatically reduced operator effort.

Implement and steering hydraulic pumps perform with high efficiency and great reliability. For improved serviceability, all hydraulic pumps are mounted on a single pump drive. Increased flow rates provide faster hydraulics and greater lift force, resulting in a better balance between breakout and rimpull.

Caterpillar's XT-3 and XT-5 hose, O-ring face seals and large-bore lift and tilt cylinders top off the hydraulic system, delivering the performance and durability owners expect. Reliable components reduce the risk of leaks and blown lines, helping protect the environment.

Automatic Ride Control* helps operators perform better. This system uses two nitrogen oil accumulators in the hydraulic lift circuit that acts like a shock absorber for the bucket. The lift arms and bucket response to movement is dampened over rough ground, reducing fore and aft pitch. A smoother, more comfortable ride gives operators the confidence to travel at higher speeds during load and carry, improving cycle times and load retention.

Ride control is easy to use.

- Using a switch in the cab, the operator can choose between three modes: off, on or automatic.
- In automatic mode, the system activates when ground speeds exceed 9.7 km/h, and deactivates at speeds below that.
- By deactivating, automatic mode offers more efficient loading and lifting by separating the accumulator from the hydraulic lift circuit, thereby providing excellent lift-linkage rigidity.

* May be optional in some countries.

Operator's Controls

A revolutionary way to operate with easy-to-use, low-effort controls.



One of the most exciting benefits of the 980G is the dramatic reduction in operator effort provided by the new Command Control steering, integrated transmission controls, finger-tip implement controls and fully hydraulic brakes. These features combine to produce the easiest operating machine in its class.

- 1 New Command Control steering** allows one hand operation of steering and transmission controls. Turning the Command Control steering plus or minus 35 degrees, left or right, from centerpoint, achieves full machine articulation. Steering stops are hydraulically cushioned. Tilt and telescoping steering column helps fit the controls to the operator, ensuring optimum ergonomics.
- 2 Finger-tip implement control levers** require very low operator effort and reduced travel. Adjust the armrest-mounted lever pod up and down, forward and back to find the most comfortable position.
- 3 Integrated transmission controls** are part of the steering design, providing one hand operation. Select forward, neutral or reverse with the three-position rocker switch. Use the thumb-operated upshift and down-shift buttons for manual shifting.

Electronic Autoshift Control allows the operator to concentrate on the work, not on gear selection.

- The operator positions a console-mounted switch to select either manual mode or auto mode. In auto mode, the operator can select the highest gear the transmission will automatically up-shift to (2nd, 3rd or 4th) using the console-mounted switch. The transmission up-shifts (depending on the selected Variable Shift Control mode) so that each shift occurs at optimum torque and ground speed matching the application/operator requirements. Also, using the console-mounted switch the operator can select the lowest gear the transmission will automatically downshift to (1st or 2nd), through the Integrated Braking System (see also on pg. 5).

Dual-pedal braking lets the left pedal function as a brake, but also integrates a transmission neutralizer and an automatic downshift logic (see also pg. 5). The right pedal functions as a regular brake. With the neutralizer, the operator can maintain high engine revolutions for full hydraulic flow (see also on pg. 10).

Transmission neutralizer lockout lets the operator shut the neutralizer off. This provides a choice to operators who prefer to operate without a neutralizer. It also provides excellent inching capability for utility work.

Operator Station

The ultimate in wheel loader operator comfort and efficiency.



The 980G cab is a spacious and comfortable work environment that promotes productive operation.

The cab includes outstanding viewing area, ease of service, ergonomic design and controls placement, improved ventilation and generous storage areas.

1 Excellent viewing in all directions.

Extended windows open the operator's view for remarkable forward and peripheral viewing including machine wheels and bucket corners. Bonded glass in the windshield eliminates frame obstructions. The stylish, sloping hood improves the view to the rear by letting the operator see objects closer to the machine.

2 New Command Control steering

features a steering wheel, with integrated transmission controls. Ergonomically integrated into the controls are two rocker switches, one for the forward/neutral/reverse selection, the other for manual up/down shifting. Load-sensing steering with flow amplification matches steering response to application requirements. Tilt and telescopic steering column helps fit the controls to the operator.

3 Electro-hydraulic, finger tip, implement controls feature extremely low effort and precise hydraulic modulation capability. The controls are seat-mounted and adjustable for outstanding ergonomics.

4 Automatic lift/lower kickouts are part of the electro-hydraulic controls and easily adjustable from inside the cab thru a simple rocker switch operation. Kickout stops are hydraulically cushioned for greater operator comfort and less material spillage.

5 980G Monitoring System consists of gauges, tachometer/speedometer and 3-level warning to ensure full time monitoring of key functions. The system alerts the operator of immediate or impending problems with engine oil pressure, parking brake, brake oil pressure, charging system, brake oil temperature, hydraulic oil level, hydraulic filter bypass, primary and secondary steering oil pressures.

6 Left, rear-hinged door provides outstanding visibility to the side of the machine as well as a secondary exit if needed. The window opens partially and locks for additional ventilation.

7 Dual brake pedals serve brake, transmission neutralizer and downshift functions so the operator can maintain high engine revolutions for full hydraulic flow and high productivity.

8 Generous storage space includes:

- Coat hook.
- Molded compartments for lunchbox, cooler, thermos, cup or can.

9 Caterpillar Contour Series air suspension seat is 6-way adjustable, providing comfort and support. The seat cushions reduce the pressure on the lower back and thighs, while offering unrestricted arm and leg movement. Air suspension adds to the overall comfort level by smoothing the ride over rough terrain. Seat is equipped with a 76 mm retractable seat belt.

10 Improved ventilation for better air flow to the operator and windows. There are twelve louvered vents with two on each door post. A large recirculation filter ensures better air quality and contributes to the operator comfort.

11 Electronic Autoshift control

12 Ride Control System switch allows the selection of three different modes:

- Off: permanently off service.
- On: permanently in service.
- Auto: in this mode, the system will automatically be actuated when the machine travels at a speed greater than 9.7 km/h (which is adjustable) and will be turned off below 9.7 km/h.

13 Transmission neutralizer lockout

14 Radio ready cab includes a 12-volt converter (5-amp), speakers, antenna, all wiring and brackets for entertainment or communications radio installation.

15 Variable Shift Control (standard), allowing the operator to select three different shift patterns based on application and working preferences.

Other options available:

- Air conditioning
- Internal mirrors
- Working lights

Versatility

Increase your productivity by performing a variety of jobs with one machine.

1 High lift arrangement

Although the standard 980G provides adequate dump clearance for most applications, the optional high lift arrangement provides even more. If you have special dump clearance needs, consider the high lift arrangement as a solution.

2 Rock excavation

The 980G was designed with excellent breakout force and increased lift force to make it a more aggressive machine in applications like rock excavation.

- Increased dump clearance allows the 980G to load 36-metric ton off-highway trucks with ease.
- Spade nose rock buckets buckets now feature 2 bolt corner guards and J400 teeth for better retention and added durability.
- Heavy-duty rock buckets with additional bucket protection are also available.

3 Material handling

The 980G's standard specifications – more power, increased torque rise, heavy-duty transmission, faster hydraulics and low-effort controls – make this machine a winner in aggregates. With outstanding second-gear performance, this machine loads trucks quickly. The high dump clearance of the standard configuration lets the 980G load off-highway trucks with ease.

4 Steel mill application

The Custom Products Steel Mill Arrangement gives the added protection needed for extended life and low operating costs in this rugged environment. Some of the features include additional guarding, hydraulic hose protection, raised air cleaner intake, remote parking brake release, engine shut down, chain clearance, slag pins, water glycol hydraulics, heavy duty lift arms, and more. Slag buckets are also available for the 980G.



Application Match

Matched payloads and matched buckets ensure optimum performance.



Truck match. Although the 980G is an aggressive 1st gear loader for face and bank excavation we also designed the versatility of a material handler into the machine. With increased rimpull and full match torque converter the 980G is an aggressive 2nd gear stockpile loader that can get the job done quickly and efficiently. With increased dump clearance the 980G can easily load on highway trucks in 2-3 passes and off highway 36 metric-ton trucks in 4 passes. Increased performance, economical 2nd gear loading and a good pass match make the 980G a versatile performer with a cost per ton that will help your bottom line.

Bucket match. With the 980G there are General Excavation, Universal and Rock buckets available in various ground engaging tool configurations and sizes. With an 11% increase in full turn static tip load and increased performance the 980G can effectively utilize the new 5.7 m³ General Excavation bucket in lighter materials ranging from 1300-1550 kg/m³ like crushed limestone.

Depending on your material densities choose a 5.4 m³ General Excavation bucket with bolt on cutting edge with even more stability. All buckets on the 980G feature the well proven shell-tine construction.

Medium Wheel Loader/Truck Application Match

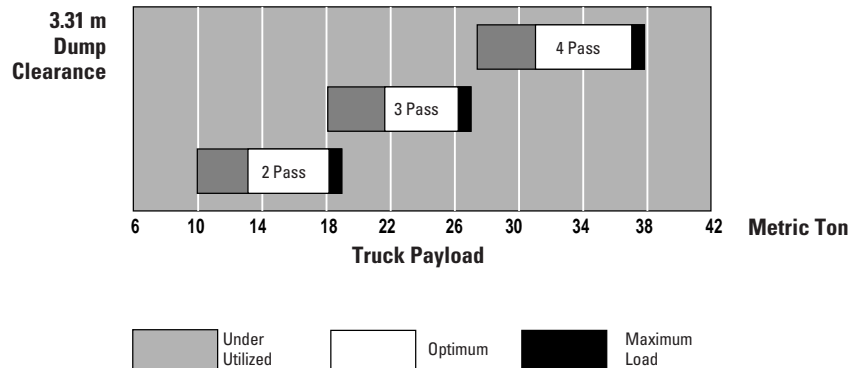

Cat Buckets and Ground Engaging Tools

Three bucket families and a large choice of Ground Engaging Tools maximize performance in all applications.

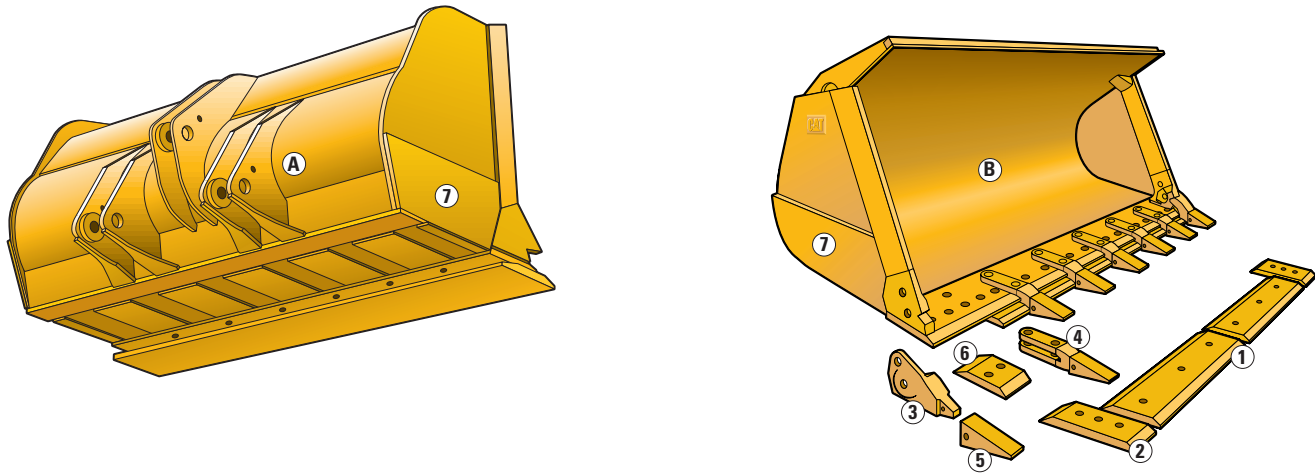

A Universal buckets with Back Grading Edge.

In this configuration, an additional full-width box-section profile with a wear edge is welded at the back of the bucket floor. The bucket base edge and the additional rear edge are at the same level, providing better grading capabilities. This bucket can be fitted with welded flush mounted adapters and tips still allowing excellent grading capability.

B General Excavation Buckets.

All General Purpose buckets have been renamed as General Excavation buckets to better reflect their application spectrum. Built to handle the toughest conditions, they feature a well proven, shell-tine construction design that resists twisting and distortion and are excellent for bank and excavation applications. Bucket hinges are part of a structure that extends under the bucket shell to the cutting edge, forming box sections. These structures act as protection against impact and twisting forces. All buckets have integral spill plates that prevent rear spillage, keeping material away from the linkage. Replaceable through-hardened weld-on rear wear plates protect the bottom of the bucket for greater durability. Bucket side plates are also reinforced in their lower portion with additional wear plates for longer life.

Corner guard system allows maximum flexibility between teeth and edge systems for superior protection and performance in each application.

Bolt-on cutting edge (1) and end bits (2)

- Standard DH-2, reversible, for superior strength and wear life.
- Heavy-duty, reversible, providing 50% more wear life.
- Abrasion Resistant Material (ARM) with impregnated tungsten carbide is another option for maximum wear life in low-to-medium impact application.

Bolt-on teeth

- New two-bolt corner adapter (3) securely attached to prevent shifting.
- Bolt-on two-strap center adapters (4).
- Seven tip options with Heavy-duty retention system. (5).

Bolt-on teeth and edge segments

- Standard reversible segments (6) protect the base edge between teeth, eliminating scalloping and maintaining a smooth work surface.
- Heavy-duty reversible segments for 50% more wear life.

Replaceable side wear plates (7) for greater durability.

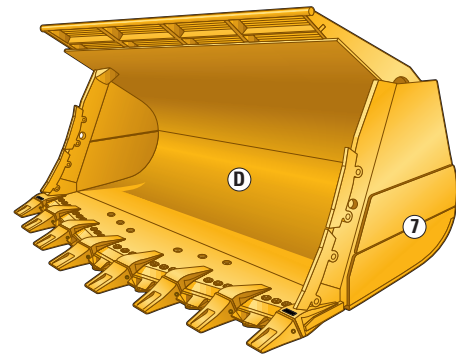
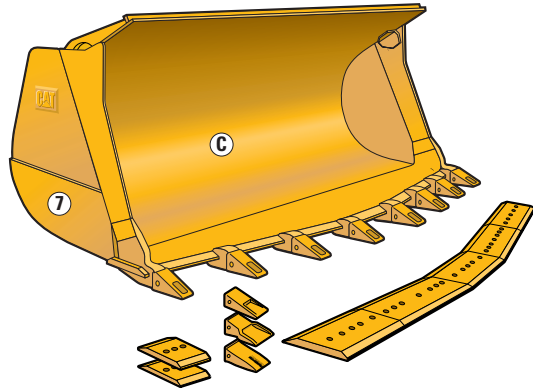

C Rock Buckets. Cat rock buckets are built to tough standards. The spade-edge design provides easier penetration and makes them well suited to high-impact jobs. Ground Engaging Tools include bolt-on cutting edge or weld-on two straps adapters to be fitted with J400 tips, with or without standard or heavy-duty bolt-on segments.

D Heavy Duty Rock Buckets offer superior protection and durability. Specifically designed for the toughest quarry, aggregates and mining operations, these buckets are factory-modified with additional protection: Liner; dual sidebar protectors; inner and outer side wear plates; outer skid plates; base edge, rear and hinge bracket wear plates; Heavy duty long life (A.R.M) corner adapters; Heavy duty adapters, tips

and segments. Each protection item was carefully chosen in response to customer requests for bucket that delivers maximum strength, durability and wear life in high impact/high abrasion conditions. These components are designed to reduce down time and bucket-related operating cost to help you get the most from your machines.

Tip Selection and GET System Selection Guide

Seven tip options are available to provide the best combination of wear life, penetration and strength needed for each application.

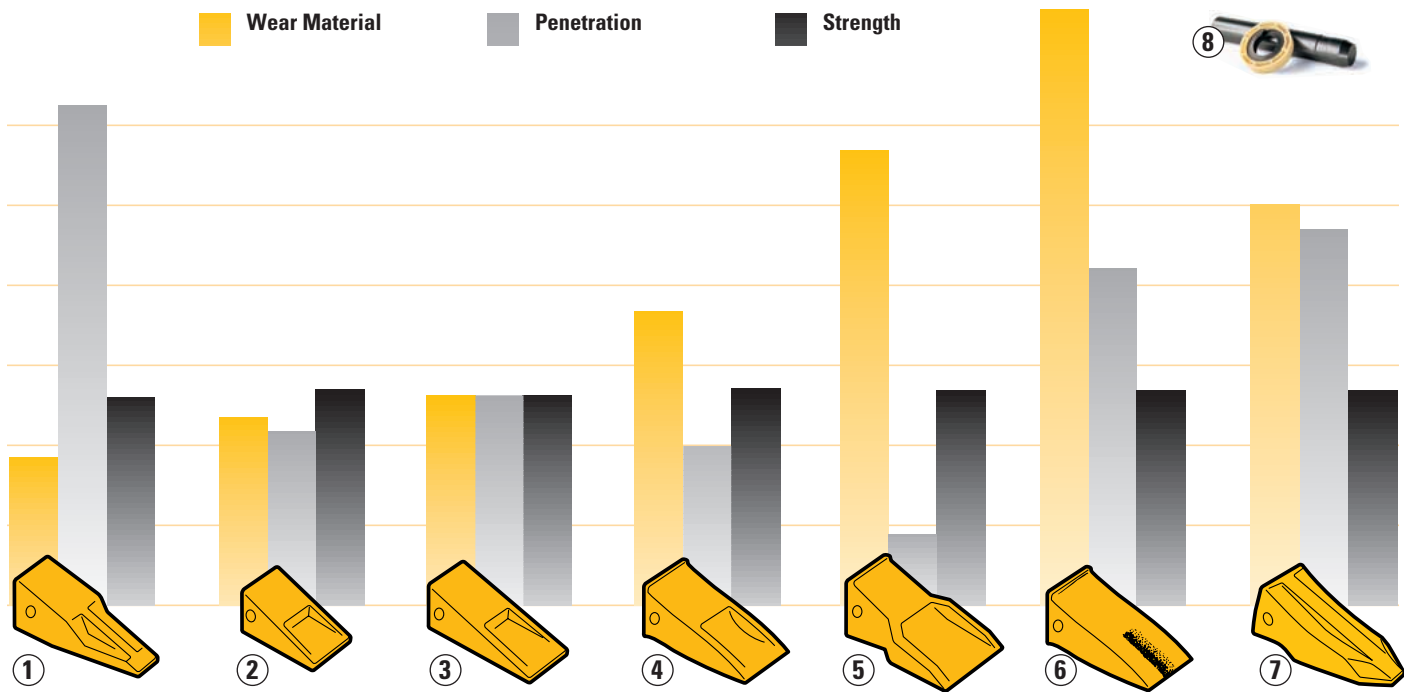

1 Penetration

- Use in densely compacted material such as clay.
- Gives maximum penetration.
- Self-sharpening.

2 Short

- Use in high-impact and pry-out work such as rock.
- Extremely strong.

3 Long

- Use in most general applications where breakage is not a problem.

4 Heavy Duty Long

- Use in general loading and excavation work.
- Has extended wear life and greater strength

5 Heavy Duty Abrasion

- Use when working in sand, gravel and shot rock.
- Maximum wear material.

6 Heavy Duty Long Life

- A.R.M. positioned to increase wear life and penetration.
- As the Heavy Duty Long Life tip wears, ease of penetration increases.

7 Heavy Duty Penetration

- Use in high-impact, hard-to-penetrate material.
- Extended wear life.

8 Heavy Duty retention system

- eliminates pin walking and the resultant tip loss in particularly severe loading conditions.

GET system selection guide

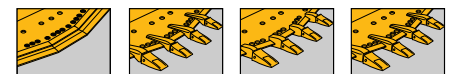
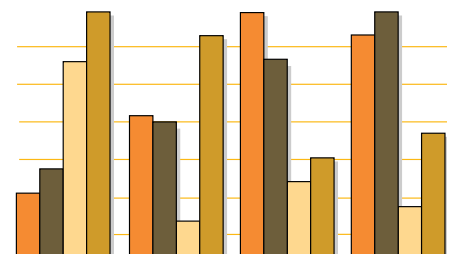

Cutting edges (bolt-on or weld-on) Flushmount adapters Bottom-strap adapters Two-strap adapters

- Penetration ability
- Impact resistance
- Wear life/Abrasion protection
- Smooth floor maintenance

Environmental Machine

Caterpillar cares about the environment and continues to develop innovative solutions.



The low sound version is standard on the 980G, which makes it two times quieter than the previous version. It is labeled at 107 and 75 dB(A) for exterior and operator station respectively. To achieve these sound levels, following modifications are made:

- An on-demand fan, which automatically regulates the fan speed depending on the cooling requirements
- Additional sound insulation around the engine

This design results in a quieter vehicle and reduced fuel consumption.

Environmental Fluid

- Extended Life Coolant/Antifreeze with anti-foaming and anti-corrosion properties provides extended service intervals (up to 6000 hours) requiring less frequent fluid renewals and disposals. This is a standard feature.

Fewer leaks and spills. Transmission and hydraulic oil filters, as well as engine oil and fuel filters are spin-on elements, positioned vertically and purposely located for a quick and easy access allowing their removal without fluid spillage. Lubricant fillers and drains are also designed to avoid spills.

Rebuildable components. Many of the major components used in the 980G are designed for rebuildability. That means you have high-quality, remanufactured (REMAN) parts available to you at a fraction of the new component cost.

Serviceability

Keep machines up and running with easy-to-perform daily maintenance.



Maintenance has never been more accessible than on G-Series machines. Fast, easy and reduced maintenance means improved uptime and greater value.

- Lockable, ground level service doors give quick access to engine oil fill and dipstick, coolant sight gauge, air filter indicator, rear grease fittings, and battery disconnect switch. Sight gauges for hydraulic and transmission oil levels are also easily viewable from the ground.
- Grouped remote grease fittings allow ground level access for lubricating tilt and steering cylinder pins and rear axle oscillation bearings.
- Caterpillar fluid filters are especially designed to assure maximum component life. The unique design uses non-metallic centertube and molded end-caps, which fully blend with media ensuring no internal leakage.
- Cat high efficiency fuel filters with STAY CLEAN VALVES™ feature cellulose/synthetic blend media that remove more than 98 percent of particles that are two microns or larger, maximizing fuel injector life.
- Caterpillar Radial Seal air filters do not require tools to service, reducing maintenance time. The ultra-high efficiency primary air filter element is coated with a fine layer of fibers that prevent dust particles from entering the filter media. This results in more efficient filtration, extended service intervals, and extended filter life – all contributing to reduced operating costs.

- Caterpillar Extended Life Coolant allows extended change intervals (6000 hours).
- Caterpillar maintenance-free, high output batteries are designed for high cranking power and maximum protection against vibration.
- Individual Multi-Row Modular core radiator reduces time to repair or replace the radiator.

Separated cooling system isolates the fan and radiator away from the engine for a quieter running machine. The oil cooler and air-conditioning condenser swing away for easy cleaning. Individual Multi-Row Modular coolant cores reduce time to repair or replace the radiator.

Reliability and durability

- **Paint Process.** Great care is given to ensure a durable paint finish. Most brackets and other hardware are zinc-plated. Larger components are all prime painted, the cab receiving a zinc-phosphate based coating to prevent rust. The entire machine, as well as decals, is finish painted with a clear, two-component, polyurethane based paint which provides a durable, UV resistant, high gloss.
- **Electrical Systems** on Cat machines are designed and manufactured to resist the most severe conditions. Harnesses are made of large-section, colored and number-coded wires, the complete harness being protected by an abrasion resistant braiding. Connectors are made of rugged thermoplastic or cast-aluminum shells, sealed against moisture and contaminants. Harnesses are properly routed and securely clamped to ensure their reliability and durability.

Sloped hood, electrically or mechanically activated, tilts up for complete access to the engine, cooling system and other major components. If needed, the hood can be removed quickly and easily by removing three pins and disconnecting a single harness connector. A built-in lifting point facilitates easy lift off.

Automatic Greasing System supplies the required quantity of grease at the right interval to the grease points automatically, without manual interference. It greases whilst the machine is in operation, resulting in better distribution of grease over the bearing surface. Also, the automatic greasing reduces downtime, repair and overhaul costs, safety and environmental hazards and greasing costs (up to 75%). The automatic greasing system is optional and being factory installed prior to final assembly.

Caterpillar engine, transmission and hydraulic oils deliver maximum performance and service life.

Factory remanufactured parts.

A large choice of factory remanufactured parts and dealer proposed repair options increases machine availability and reduces repair cost.

Preventive Maintenance

By anticipating potential problems and avoiding unscheduled repairs, your equipment is always up and ready to run.



Caterpillar Monitoring System

Caterpillar Monitoring System (CMS) monitors all key controls and functions. The system alerts the operator of immediate or impending problems with engine oil pressure, brake oil pressure, parking brake, electrical charging system, low fuel level, hydraulic oil level, hydraulic filter and primary and secondary (if equipped) steering. In the service mode, the digital panel displays operating parameters, diagnostic codes and out-of-range gauge readings. It also calibrates the electronic lift and tilt controls as well as the electronic transmission controls. More than 90 fault codes are already visible on the CMS screen in the cab. They are documented in the Operation and Maintenance Manual of the machine allowing you to identify directly where the potential defect has occurred.

- 1 ET software
- 2 Communications Adapter
- 3 Diagnostic Connector
- 4 Electronic Control Modul (ECM)

Electronic Technician

Caterpillar Electronic Technician (ET) is a software program which allows the service technician to find and identify a problem on a machine and to analyze how to fix it quickly. ET provides him with the capability to access the Electronic Control Modules from a personal computer.

The Electronic Technician is used for:

- Viewing active and non active diagnostic codes and clearing them after repair.
- Displaying the status of all parameters such as engine speed, gear engaged, control levers position, control switch position, etc.
- Performing diagnostic test and calibrations of electro-hydraulic components.
- Viewing current configuration and changing parameter settings.
- Flashing new Caterpillar softwares in the Electronic Control Modules.
- Recording all parameters during machine operation.

A customer version of ET is also available for your fleet of Caterpillar equipment. Contact your Caterpillar dealer for more detailed information.

Scheduled Oil Sampling (S•O•S) analysis

Caterpillar has specially developed S•O•S. to help ensure better performance, longer life and increased customer satisfaction. It is an extremely thorough and reliable early warning system which detects traces of metals, dirt and other contaminants in your engine, axle, transmission and hydraulic oil. It can predict potential trouble early, thus avoiding costly unscheduled failures. Your Caterpillar dealer can give you results and specific recommendations shortly after receiving your sample.

Each S•O•S test can provide specific types of diagnostic:

- **Oil condition analysis** identifies loss of lubricating properties by quantifying combustion products such as soot, sulfur, oxidation and nitrates.
- **Wear analysis** monitors components wear by detecting, identifying and assessing the amount and type of metal wear elements found in the oil.
- **Chemical and physical test** detect the physical presence of unwanted fluids (water, fuel, antifreeze).

Engine

Four-stroke cycle, six cylinder 3406C direct injected, turbocharged and aftercooled diesel engine.

Ratings

	kW	hp
Maximum flywheel power at 1800 rpm	239	321

The following ratings apply at 2100 rpm when tested under the specified standard conditions:

Rated flywheel power	kW	hp
ISO 9249	224	300
EEC 80/1269	224	300

Maximum flywheel torque at 1000 rpm	1668 Nm
-------------------------------------	---------

Total torque rise	64%
-------------------	-----

Dimensions

Bore	137 mm
------	--------

Stroke	165 mm
--------	--------

Displacement	14.6 liters
--------------	-------------

Exhaust emissions

The 3406C meets the following emissions requirements:

- EU (97/68/EC standard)
- US EPA
- Japan MOC

Power rating conditions

- net power advertised is the power available when the engine is equipped with alternator, air cleaner, muffler and hydraulic fan drive
- no derating required up to 2300 m altitude

Features

- direct-injection fuel system with individual adjustment-free injection pumps and valves
- 3-ring aluminum-alloy pistons, cam-ground, tapered and cooled by oil spray
- steel-backed, copper-bonded aluminum bearings
- high carbon steel alloy crankshaft with hardened journals
- pressure lubrication with full-flow, filtered oil and heat exchanger oil cooler
- dry-type air cleaner with primary and secondary elements with automatic dust ejector and service indicator
- direct-electric 24-volt starting and charging system

Transmission

Planetary power shift transmission with four speeds forward and reverse.

Maximum travel speeds (29.5-25 tires)

Forward	km/h
1	7.0
2	12.3
3	21.6
4	37.4

Reverse	km/h
1	8.0
2	14.0
3	24.6
4	42.8

Features

- integrated controls in steering wheel for both speed and direction
- electronic autoshift
- quick gear upshift/downshift buttons
- single-stage, single-phase torque converter
- separate lock to keep transmission in neutral
- transmission can be recalibrated using Electronic Technician (ET) service tool
- Variable Shift Control controlling the selected shift pattern

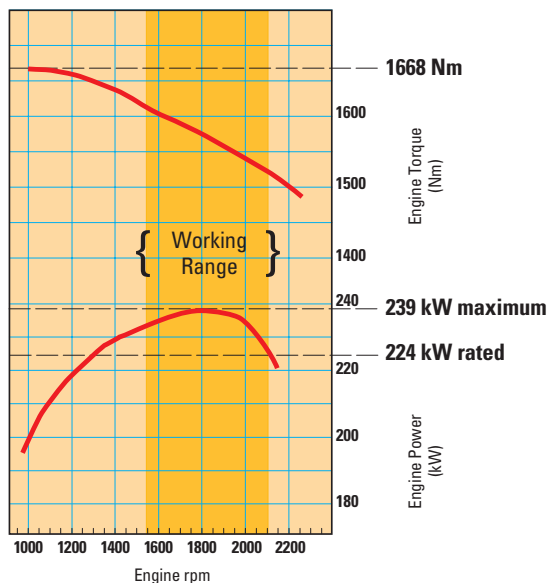

High Torque Rise

The direct injected fuel system delivers a controlled increase of fuel as the engine lugs back from rated speed. This results in horsepower greater than rated power. The combination of increased torque rise and maximum horsepower improves response, provides greater rimpull, more lift force and faster cycle times. The 239 kW (321 hp) maximum power occurs at 1800 rpm when power is needed during the working cycle.

Axles

Fixed front, oscillating rear ($\pm 13^\circ$).

Features

- maximum single-wheel rise and fall: 550 mm
- conventional differential is standard
- free-floating axle shafts can be removed independently from wheels and planetary final drives
- optional limited slip differentials front and rear

Brakes

Meet the following standard:
ISO 3450-1985.

Service brake features

- four wheel, hydraulic, oil cooled, multiple-disc brakes
- completely enclosed
- self adjusting with modulated engagement
- dual pedal braking system with transmission neutralization

Parking brake features

- spring applied, oil-released, dry drum brake
- mounted on transmission output shaft for manual operation
- electronic monitoring system alerts operator if transmission is engaged while parking brake is applied

Secondary brake features

- electronic monitoring system alerts operator if pressure drops and automatically diverts to the parking brake
- operator can apply manually

Final Drives

All Wheel drive.

Features

- planetary reduction at each wheel
- torque developed at the wheel, less stress on the axle shafts
- planetary units can be removed independently from the wheels and brakes

Hydraulic System

System is completely sealed. Innovative low-effort controls.

Implement system (standard), 2-section vane pump

Output at 2100 rpm and 6900 kPa with SAE 10W oil at 66°C	480 lpm
Relief valve setting	20 700 kPa
Cylinders, double acting: lift, bore and stroke	196.9 x 864 mm
Cylinder, double acting: tilt, bore and stroke	159 x 582 mm

Pilot system, gear-type pump

Output at 2100 rpm and 3450 kPa	21 lpm
Main valve setting	3450 kPa

Hydraulic cycle time (standard)

Raise	6.0
Dump	2.0
Lower, empty, float down	3.4
Total	11.4 seconds

Features

- completely enclosed system
- low-effort, electro-hydraulic pilot-operated controls

Cab

Caterpillar cab and Rollover Protective Structure (ROPS) are standard.

Features

- ROPS meets the following criteria:
 - ISO 3471:1994
- also meets the following criteria for Falling Objects Protective Structure:
 - ISO 3449:1992 LEVEL II
- corrosion-free roof cap

Implement Controls

Lift circuit features

- four positions: raise, hold, lower and float
- in-cab, programmable high and low lift kickouts with cushioned stops

Tilt circuit features

- three positions: tilt back, hold and dump
- can adjust automatic bucket positioner to desired loading angle
- does not require visual spotting

Controls

- two lever control (standard)
- three lever control (optional)

Load Sensing Steering

Full hydraulic power steering.

Features

- center-point frame articulation
- front and rear wheels track
- hydraulic power with flow-amplified system
- steering-wheel operated pilot valve controls flow to steering cylinders
- full-flow filtering
- adjustable steering column

Service Refill Capacities

	Liters
Fuel tank – standard	470
Cooling system	79
Crankcase	28
Transmission	62
Differentials and final drives	
front	87
rear	81
Hydraulic system (including tank)	208
Hydraulic tank	125

Sound Levels/Dynamics

Operator sound	dB(A)
Standard low sound*	75
Exterior sound	
Standard low sound*	107

* According to EU 2000/C 83/01 requirements.

The 980G standard low sound is more than 2 times quieter than the previous 980G, which was at the legally required 111 dB(A).

The operator sound pressure levels are measured according to the dynamic test procedures and conditions specified in ISO6396. The exterior sound power levels are measured according to the dynamic test procedures and conditions specified in ISO6395 and 95/27/EC.

Tires

Choose from a variety of tires to match your application.

Choice of

- 29.5-R25 XHA 1 STAR L-3 (rock) standard
- 29.5-R25 XLDD2 1 STAR L-5 (extra deep tread)
- 29.5-R25 XMINE D2 (extra deep tread)
- 26.5-R25 L-3 (rock)
- 29.5-25 22PR L-3 (rock)
- 29.5-25 22PR L-5 (extra deep tread)
- 29.5-R25 GP2B L-2/L-3 (traction-rock)
- 29.5-R25 RL2+ (traction-rock)
- 26.5-R25 L-2/3 (traction-rock)
- 26.5-25 20PR L-3 (rock)
- 26.5-25 20PR L-5 (extra deep tread)

In certain applications (such as load-and-carry work) the loader's productive capabilities might exceed the tires' tonnes-km/h capabilities. Caterpillar recommends that you consult a tire supplier to evaluate all conditions before selecting a tire model.

Dimensions

All dimensions are approximate.

◆ Dimensions vary with bucket or tires. Refer to operation specifications chart on page 24-25 or to Supplemental Specifications chart on this page.

▲ Standard machine 4505 mm
Optional high lift 4727 mm

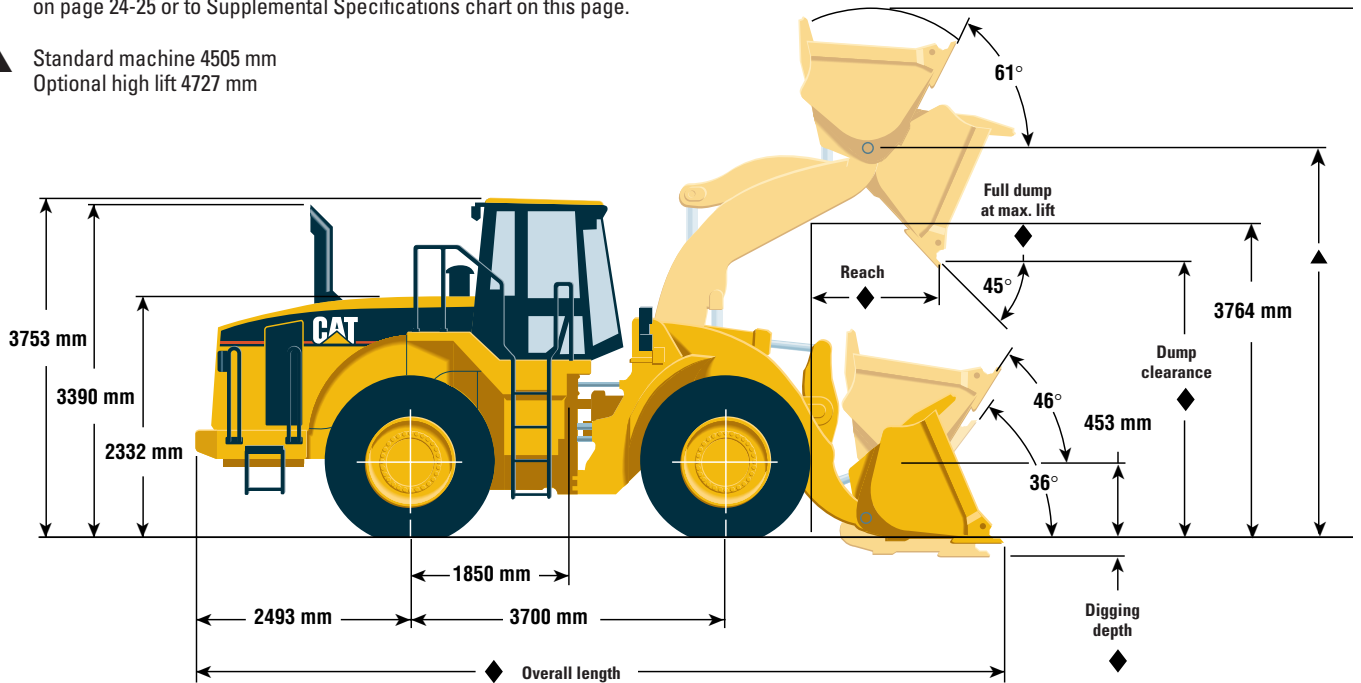

Tread width for 29.5-25 is 2440 mm
Tread width for 26.5-25 is 2368 mm

Supplemental Specifications

	XHA	XLDD2	XMNED2	22PRL3	22PRL5
Tread type	L3	L5	L5	L3	L5
Dimension	29.5 x 25	29.5 x 25	29.5 x 25	29.5 x 25	29.5 x 25
Width over tires (mm)	3192	3247	3202	3225	3245
Change in all vertical dimensions (mm)	Used as reference	+23	+39	+11	+46
Weight variation (kg)	0	+868	+1156	-323	+951
Change in static tipping load (kg)					
full articulation	0	+685	+913	-255	+751
	XHA	GP2B	GP2B	20PRL3	20PRL5
Tread type	L3	L2/3	L2/3	L3	L5
Dimension	26.5 x 25	26.5 x 25	29.5 x 25	26.5 x 25	26.5 x 25
Width over tires (mm)	3041	3049	3215	3059	3071
Change in all vertical dimensions (mm)	-57	-55	+1	-53	+3
Weight variation (kg)	-675	-675	-82	-805	+55
Change in static tipping load (kg)					
full articulation	-57	-55	-65	-53	+3

Operation Specifications

		General Excavation Buckets					
		Bolt-on Cutting Edge	Bolt-on adapters, Tips and Segments (no GET)	Bolt-on Cutting Edge	Bolt-on adapters, Tips and Segments (no GET)	Bolt-on Cutting Edge	Bolt-on adapters, Tips and Segments (no GET)
Rated bucket capacity	m ³	4.6	4.6 (4.2)	5	5 (4.7)	5.4	5.4 (5)
Struck capacity	m ³	3.9	3.8 (3.7)	4.2	4.2 (4.0)	4.6	4.5 (4.4)
Width	mm	3447	3533 (3405)	3447	3533 (3405)	3447	3533 (3405)
Dump clearance at full lift and 45° discharge ⁴	mm	3306	3131 (3439)	3306	3131 (3375)	3249	3084 (3319)
Reach at full lift and 45° discharge ⁴	mm	1491	1642 (1421)	1491	1642 (1484)	1547	1712 (1542)
Reach with lift arms horizontal and bucket level ⁴	mm	3028	3259 (2885)	3028	3259 (2975)	3109	3342 (3055)
Digging depth	mm	145	162 (103)	145	162 (103)	145	147 (103)
Overall length ⁴	mm	9294	9513 (9115)	9294	9513 (9206)	9374	9585 (9285)
Overall height with bucket at full raise	mm	5991	5991 (5991)	6065	6065 (6065)	6134	6134 (6134)
Loader turning radius with bucket in carry position	mm	7836	7933 (7781)	7861	7958 (7805)	7883	7981 (7826)
Bucket weight	kg	2604	2677 (2204)	2705	2778 (2305)	2797	2870 (2397)
Static tipping load straight ¹	kg	20090	20000 (20900)	19800	19700 (20500)	19500	19500 (20200)
Static tipping load at 37° articulation ¹	kg	18110	17980 (18850)	17800	17730 (18540)	17530	17500 (18300)
Breakout force ²	kN	242	219 (276)	240	235 (255)	225	222 (239)
Operating weight ¹	kg	29382	29455 (26778)	29483	29556 (26778)	29575	29648 (29175)

¹ Static tipping load and operating weight shown are based on average machine configuration with sound-suppression cab and ROPS, secondary steering, air conditioning, ride control, 29.5-R25, L-3, tires, full fuel tank, coolant, lubricants, lights, directional signals with CE plates and operator.

² For buckets with adapters, tips and segments, value is measured 102 mm behind the tip of the segment, with bucket hinge pin as pivot point, in accordance with SAE J732C.

³ All buckets shown can be used on the high lift arrangement. High lift column shows changes in specifications from standard lift to high lift. Add or subtract as indicated to or from specifications given for appropriate bucket to calculate high lift specifications.

Dimensions for dump clearance, reach and overall length:

⁴ Actual dimensions taken at the tip of the Ground Engaging Tools, either the tip of the bolt-on cutting edge or the tip of the teeth, type long.

	Rock Buckets						High Lift ³
	Bolt-on Cutting Edge	Bolt-on adapters, Tips and Segments (no GET)	Adapters, Short Tips (no GET)	Adapters, Segments and Long Tips	Adapters and Long Tips (no GET)	Adapters, Segments and Long Tips	
	5.7	5.7 (5.4)	4.2 (4.2)	4.5	4.8 (4.8)	5.1	same
	4.9	4.9 (4.7)	3.5 (3.5)	3.7	4.0	4.3	same
	3447	3533 (3405)	3620 (3492)	3492	3645 (3645)	3645	same
	3214	3039 (3283)	2838 (3004)	3122	2903 (3105)	2903	+220
	1583	1734 (1576)	1955 (1788)	1619	1745 (1580)	1745	+2
	3158	3389 (3105)	3687 (3452)	3176	3419 (3161)	3419	+159
	145	162 (102)	200 (152)	148	183 (175)	183	+99
	9424	9643 (9335)	9917 (9682)	9637	9907 (9644)	9907	+201
	6205	6205 (6205)	6363 (6363)	6356	6245 (6245)	6245	+221
	7896	7995 (7836)	8022 (7885)	7861	7982 (7899)	7982	+72
	3052	3125 (2652)	3257 (2873)	3201	3428 (3041)	3697	same
	19100	19000 (19800)	19500 (19800)	22047	21592 (22071)	21014	-1528
	17130	17070 (17860)	17480 (17820)	19829	19404 (19879)	18848	-1410
	216	212 (229)	188 (225)	219	195 (197)	192	same
	29830	29903 (29430)	30035 (29651)	30814	31041 30654	31310	+195

Bucket Selection Guide

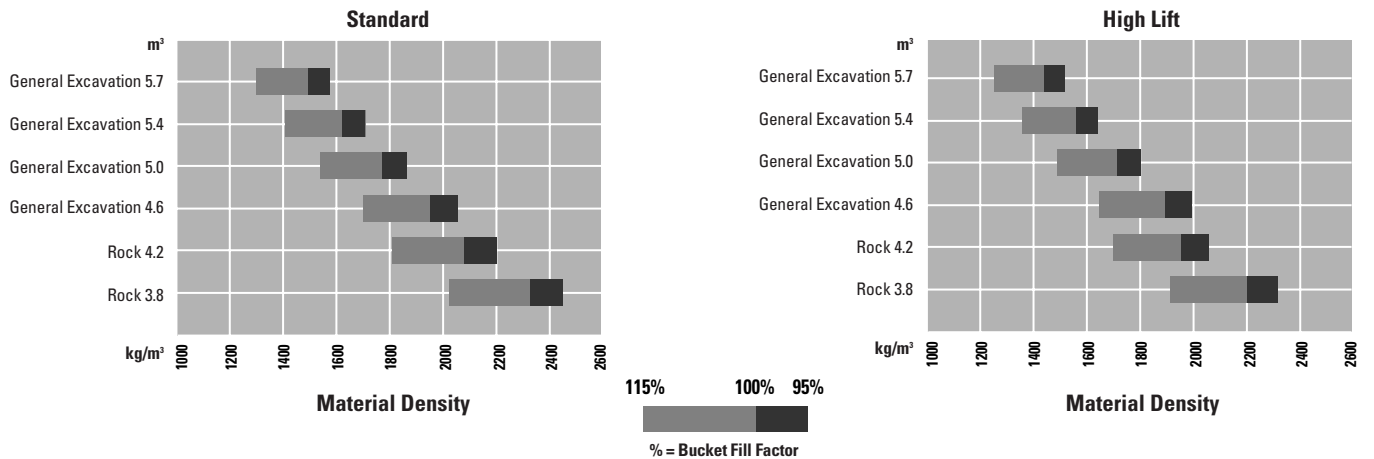

Standard Equipment

Standard equipment may vary. Consult your Caterpillar dealer for specifics.

Electrical

- 70-ampere alternator
- Directional signals*
- Electric starter (heavy-duty)
- External lighting system (front and rear)
- Maintenance-free batteries
- Starting and charging system diagnostic connector

Operator environment

- Adjustable steering column
- Air-conditioning (R134a refrigerant)*
- Air suspension seat
- Cigar lighter
- Dome light (cab)
- Electric horn
- Electro-hydraulic implement controls
- Heater and defroster
- Integrated ROPS structure
- Implement system lock
- Monitoring system
 - Gauges:
 - speedometer
 - tachometer
 - fuel level
 - hydraulic oil temperature
 - transmission oil temperature
 - engine coolant temperature
 - brake oil pressure
- Radio-ready cab for entertainment or 2-way radio (3-point mounting)
- Rearview mirrors (exterior mounted)
- Retractable seat belt 76 mm wide
- Sliding windows*
- Sound-suppressed pressurized cab
- Wet-arm wiper/washers (front and rear)

Power train

- Automatic planetary power shift transmission with fully automatic speed range control
- Cat 3406C DITA direct injected turbocharged and aftercooled diesel engine with 24-volt direct electric starting system
- Engine air intake precleaner
- Fuel priming aid
- Full hydraulic, enclosed, wet multiple-disc brakes
- Integrated Braking System
- Multi row module radiator
- On demand radiator cooling fan, hydraulically driven
- Sound suppressed muffler
- Torque converter
- Transmission neutralizer on/off switch
- Variable Shift Control

Other standard equipment

- Adjustable automatic bucket positioner
- Adjustable from cab automatic lift kickout
- Counterweight
- Crankcase guard
- Drawbar hitch with pin
- Front and rear non-metallic fenders
- Fenders (front and rear)/extensions*
- Hydraulic oil cooler
- Locking engine enclosures
- Low sound package
- Power tilt engine enclosure
- Sound suppression package
- Secondary steering*
- Ride control system*
- Temperature sensing fan
- Vandalism protection caplocks*

Tires

Several tire options are available

* May be optional in some countries

Optional Equipment

Optional equipment may vary. Consult your Caterpillar dealer for specifics.

Back-up alarm
Buckets, see pg. 14-16
Bucket teeth tips, eight required per bucket
Differentials, limited slip
Ether starting aid
Fast fill systems
 Fuel
 Oil
Guard, power train
Heater, engine coolant

High lift arrangement
Hydraulic arrangement, three-valve
Light, warning, rotating beacon
Payload Measurement System
Prescreener, conversion kit
Radio, AM/FM
Tires, see pg. 22-23
Tool box, locking, waterproof
Tool kit
Wet disc parking brake

Loader Compactor Arrangement

providing versatility to compact, to spread, to load and to doze trash in landfills.

Steel Mill Arrangement providing extensive protection to deliver the expected durability while working in harsh environments of the steel mill and slag handling industries.

Block Handler Arrangement providing all the necessary features to withstand heavy-duty requirements of marble block handling in quarry applications.

Underground Mining Arrangement providing ability to work in confined underground mines.

Anti-Corrosion Arrangement providing extensive protection to vital machine components and other surfaces in harsh corrosive applications.

Logger Arrangement keeping your millyard operation efficient and productive at every stage.

980G Wheel Loader

HEHL5151-2 (03/2001) hr

Materials and specifications are subject to change without notice.
Featured machines in photos may include additional equipment.
See your Caterpillar dealer for available options.

www.CAT.com
© 2000 Caterpillar

CATERPILLAR[®]