

992G

Wheel Loader



Bucket capacities	11.5 to 12.3 m ³
Operating weight	93 779 kg
Cat [®] 3508B EUI Engine	
Gross power	656 kW/880 hp
Flywheel power	597 kW/800 hp

992G Wheel Loader

A new standard for wheel loader productivity, serviceability and styling.

Structures and Cast Box Boom

- The articulated frame design features a high-torsion, compact, load-absorbing, front frame and a large, modulus, box-section, engine-end frame. *New cast box boom and redesigned linkage geometry increase dump clearance, provide excellent breakout force and increase the viewing area to the bucket and target.* **pg. 4-5**

Engine

- ✓ The turbocharged 3508B *Electronic Unit Injection* diesel engine delivers increased power, improved torque rise and 14 percent more usable rimpull. Newly designed pistons and turbocharger, along with higher injection pressures, result in improved combustion and lower emissions. **pg. 6**

Power Train

- Designed for durability, the Caterpillar® planetary power shift transmission and ✓ *impeller clutch torque converter* provide smooth, consistent shifting with ✓ *finger tip control.* *Electronic controls* contribute to increased levels of productivity. **pg. 6-7**

Hydraulics and Electronic Monitoring

- Innovative electro-hydraulics play a key role in performance of the 992G and ✓ provide low operator effort. *Increased pressure and hydraulic efficiency improve lift and tilt cycle time for reduced overall cycle time.* The tradition of reliable, high-performance Caterpillar hydraulics continues. **pg. 8-9**

Operator Station and Controls

- Experience a new level of efficiency and comfort with one-hand operation provided by the STIC controller and ✓ *a 75 percent larger cab.* *Operator productivity is also increased with low-effort, finger tip implement controls, improved range of viewing, reduced sound levels, improved ventilation and easier entry and exit.* **pg. 10-11**

Innovative performance you can feel.

Increased power and torque rise, stronger power train components, cast box boom, electro-hydraulic controls coupled with increased bucket size and higher lifting capacity make the 992G a revolutionary advancement in large wheel loader design.



Buckets and Ground Engaging Tools

- ✓ Choose between a variety of new 11 to 13 m³ capacity buckets, spade-edge buckets and heavy duty mining buckets, with various Ground Engaging Tools to match job conditions. Replaceable weld-on wear plates on the bucket heel protect the bottom of the buckets. Built by Caterpillar, these buckets retain the proven shell-tine construction design for unmatched durability. **pg. 12**

Serviceability

- ✓ Perform maintenance jobs with *easy access to major service points* such as oil levels and fills, grease fittings, sight gauges, filters and electrical breakers. A diagnostic connector allows quick
- ✓ *electronic analysis. Improved access to the hydraulic valve and a reduction in connections also enhance serviceability.* **pg. 15**

Cat '5 Star Customer Service'

- Turns your investment into profit, from purchase to resale through:
- Equipment Management Services for optimum profit
 - Maintenance Services for equipment protection
 - Predictive Services for optimum availability
 - Reconditioning Services for lower repair cost
 - Your Caterpillar dealer for satisfaction and peace of mind
- pg. 16**

Bucket and Application Truck Match

Increased performance and good pass matching make the 992G a versatile performer. Proper bucket and payload matching produce increased stability and performance. **pg. 13-14**



✓ *New feature*

Structures and Cast Box Boom

Superior design of structures, along with bold, new cast-steel, box section front linkage, provide superior strength.

The structures on the 992G combine the use of robotic welding and castings in critical high-stress areas. More than 90 percent of the 992G structure is robotically welded to provide highly consistent welds and increased strength. Castings are also used in several areas to increase strength by helping to spread the loads and reduce the number of parts.

- 1 Full box-section frame** has been redesigned for maximum strength and minimum weight. The frame rail is now extended further forward, improving rail to hitch strength.
- 2 Box-shaped cylinder tower** is designed for improved resistance to twisting for maximum strength. The tilt cylinder tower high-strength steel plates direct stress down to the cast tube, absorbing impact and loading forces. This design results in a narrower tower which gives better operator visibility.
- 3 Upper and lower hitch-pins** pivot on double-tapered roller bearings and are shaped to direct stress away from the end of the weld, resulting in a smoother transition of stress loads.
- 4 Spread-hitch design** helps to square up the frame while providing increased clearance for access to the hitch and hydraulic lines.
- 5 Steering cylinder mounts** are located on the outboard side of the front frame to increase component clearances and structural strength, while improving serviceability.

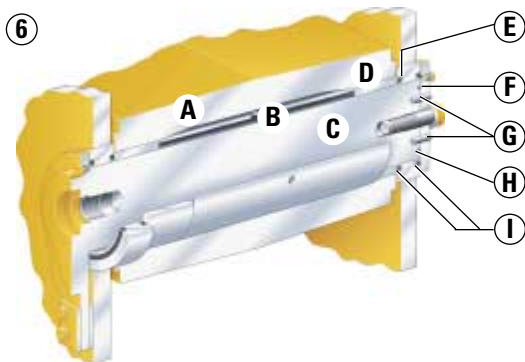

Oil-filled linkage joint

- A Boom assembly
- B Spacer
- C Pin assembly
- D Bearings (2)
- E Collars (2)
- F Cover assembly
- G Dowel
- H O-Ring seal
- I Seals (4)

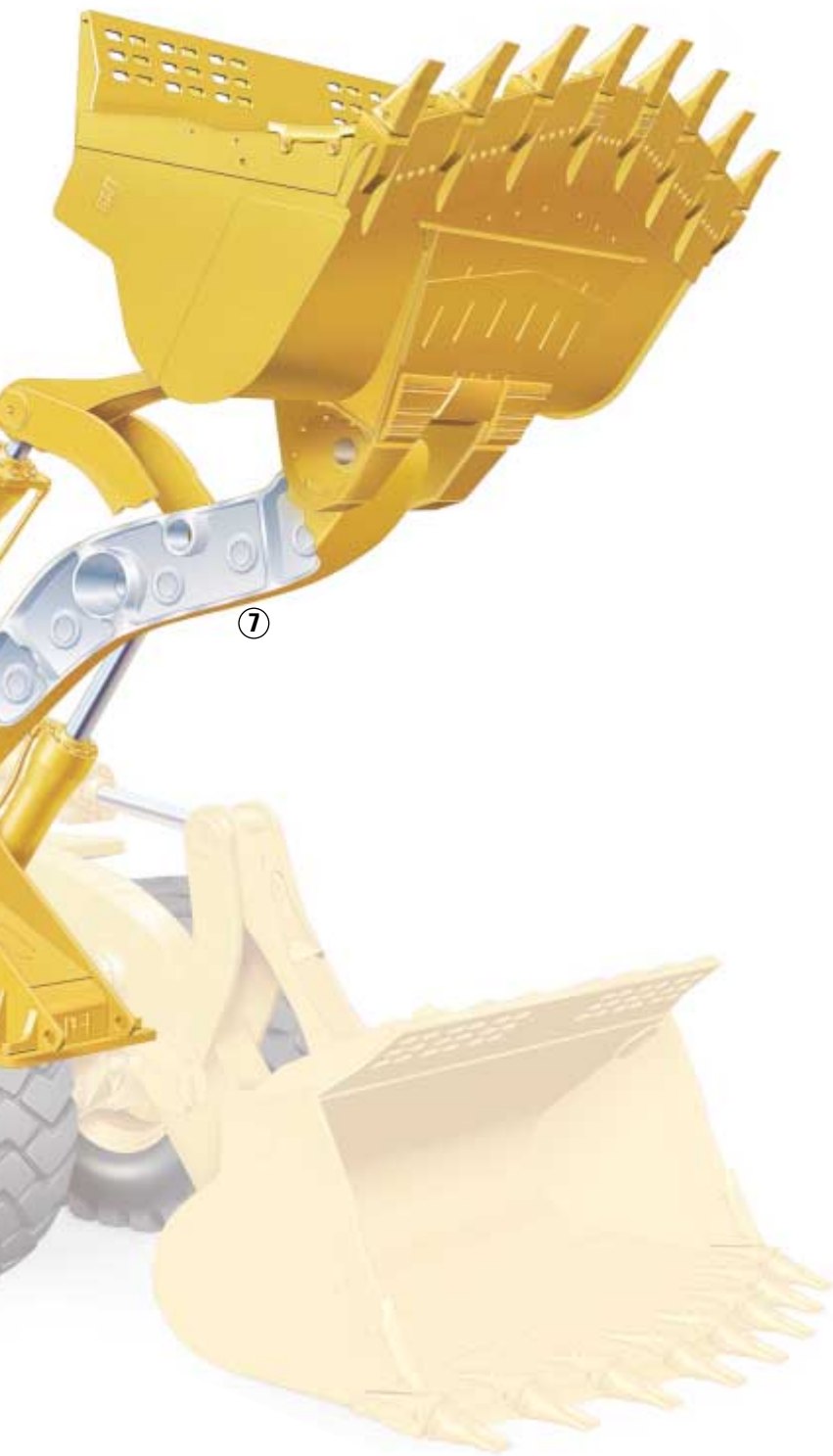

6 Six linkage joints are oil-filled, low maintenance joints which do not require daily service. Vented dipsticks are included in several joints improving serviceability by providing a simpler means of maintaining proper oil levels. The linkage joint seals have a metal core that protects the seal during normal bending and flexing that occurs while loading. Two linkage joints require normal greasing, the upper bucket pin and the tilt link pin.

7 One-piece, box-section, steel casting boom design replaces the traditional steel plate lift arms associated with wheel loaders. This design provides improved viewing of the bucket and represents a substantial vehicle weight savings over a comparable Z-bar linkage, resulting in improved stability, better horsepower-to-weight ratio and improved fuel efficiency.

8 Box-section design of the cast box boom delivers three times the torsional loading strength of the previous design. (With the parallel lift arm design, corner loading the bucket stresses up the lift arm, through the cross tube welding and up the other lift arm.) The box-section design spreads stresses over the full length and perimeter of the cast box boom, allowing stress transfer through parent material. This resists twisting and prevents stress paths that can lead to cracking.

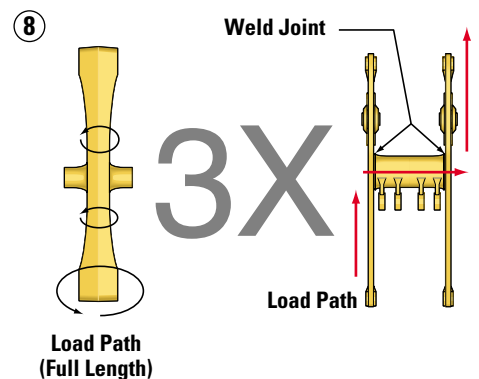

Power Train

Cat power train delivers top performance and durability in tough applications.

1 The Cat 3508B Diesel Engine is a four-stroke design and uses long, effective power strokes for more complete fuel combustion and optimum efficiency. The 3508B is designed with large displacement and a low speed rating for long hours of service between scheduled overhauls and lower operating costs.

- **The 30 percent torque rise** provides high lugging force during digging and acceleration in high rimpull conditions. The torque curve effectively matches the transmission shift points to provide maximum efficiency and faster cycle times.
- **Electronic Unit Injection (EUI)** is a proven high-pressure, direct injection fuel system that electronically monitors operator demands and sensor inputs to optimize engine performance.
- **Advanced Diesel Engine Management (ADEM)** system controls the fuel injector solenoids to start and stop fuel injection. This system provides automatic altitude compensation, air filter restriction indication, and will not allow the engine to fire until it has oil pressure, acting as a cold start protection and a form of pre-lube.

2 Separate engine cooling system isolates the radiator and fan from the engine compartment providing lower sound levels, more efficient cooling and a sloped hood for increased viewing.

- **Advanced Modular Cooling System (AMOCS)** improves cooling capabilities by using a parallel flow system with 16 cores. Serviceability is improved with AMOCS as there is no top tank to remove and the radiator guard does not have to be tilted to remove the cores.
- **Separate Circuit Aftercooling (SCAC)** dedicates six of the radiator's cores to the independent aftercooler circuit. This allows the aftercooler circuit to operate cooler resulting in denser air charge and improved emissions.

3 Caterpillar planetary, power shift transmission features perimeter-mounted, large diameter clutch packs that control inertia for smooth shifting and increased component life. The electronically controlled transmission enhances productivity, durability and serviceability.

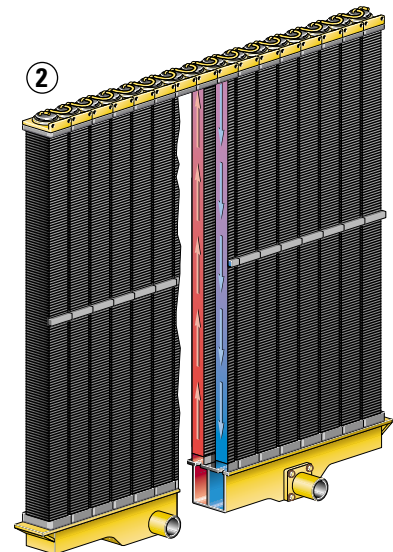
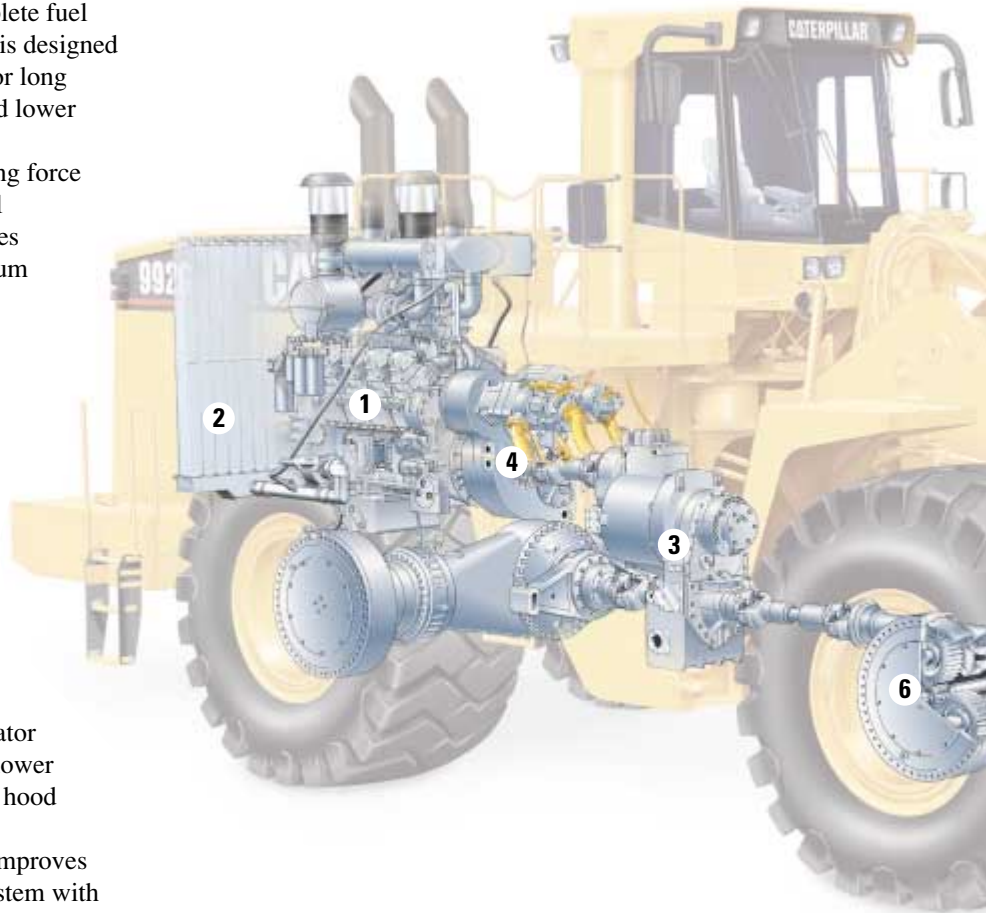



- Rimpull Control System (RCS) allows the operator to select from four preset maximum rimpull settings available in first gear (80,65,50 and 35 percent).
- A lock-up clutch torque converter is also available as an optional attachment.

5 Heavy Duty Axles feature standard axle oil coolers, permanently lubed universal joints and stronger axle components in both the differentials and final drives for increased performance, serviceability and durability.

- Free floating axle shafts can be removed independent of the wheels and planetaries for quick and easy serviceability.
- Axle oil cooling system circulates oil from the brakes and differentials through an oil-to-air cooler providing increased oil life while extending component performance and durability.

6 Oil-enclosed, multiple-disc brakes are adjustment free with fewer parts for improved serviceability. Fully hydraulic actuators with independent front and rear circuits use separate accumulators and new valves for increased performance and reliability.

- Location of the brakes improves serviceability. The axle-shaft brake design allows brake service while leaving the final drive intact.
- Axle shaft brakes require less force by operating on the low torque side of the axle. Combined with improved axle oil circulation for increased cooling, the oil-enclosed, multiple-disc brake design improves durability.

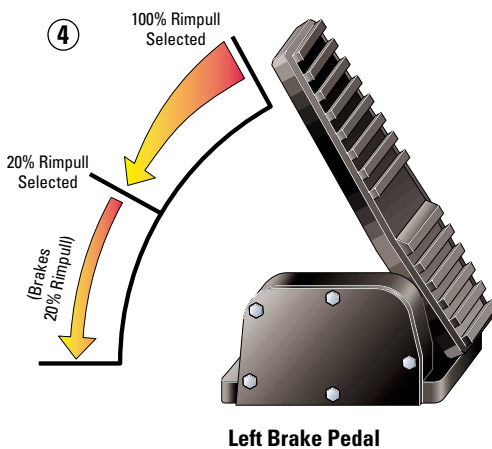

4 Impeller Clutch Torque Converter (ICTC) combined with the Rimpull Control System (RCS) allows the operator maximum flexibility in modulating rimpull.

- The impeller clutch torque converter uses the left brake pedal to modulate rimpull from 100 to 20 percent for reduced tire slippage. After 20 percent is achieved, further pedal travel applies the brake.

Hydraulics and Electronic Monitoring

Precise, low-effort control and trouble-free operation of well balanced hydraulics, combined with electronic controls and machine diagnostics, provide optimized performance and durability.



1 Revolutionary electro-hydraulic control system uses separate hydraulic circuits for the implement/engine fan and steering/brake control. The benefits of the separate hydraulic systems are increased cooling and elimination of cross-contamination. Caterpillar's XT-3 and XT-5 hose and reliable components help reduce the risk of leaks and blown lines, helping protect the environment.

2 Lift and tilt system consists of larger bore lift and tilt cylinders and a combination of variable and fixed displacement pumps contributing to increased performance and serviceability.

- **The variable displacement pump** is controlled by the Electronic Control Module (ECM).

A solenoid valve controls the torque settings allowing the ECM to vary the hydraulic load felt by the engine. This strategy results in faster hydraulics and greater lift forces leading to optimized performance.

- **Fixed displacement hydraulic pump** performs with high efficiency and great reliability. For improved serviceability, all hydraulic pumps are mounted on a single pump drive.



3 Load Sensing Steering with STIC control system integrates steering and transmission into a single controller. The steering system utilizes a variable displacement pump for maximum machine performance by directing power through the steering system only when needed.

4 Case Drain Filtration is included throughout the hydraulic system to protect against contamination. Easily accessed for serviceability, eight filters in total protect the hydraulic pumps, fan motor and axle oil cooler circuit.

- Optional high pressure screens are available as an upgrade to the case drain filtration package. This Deluxe Filtration package places high pressure screens on the output side of the hydraulic pumps and fan motor, further protecting the hydraulic system from contamination.

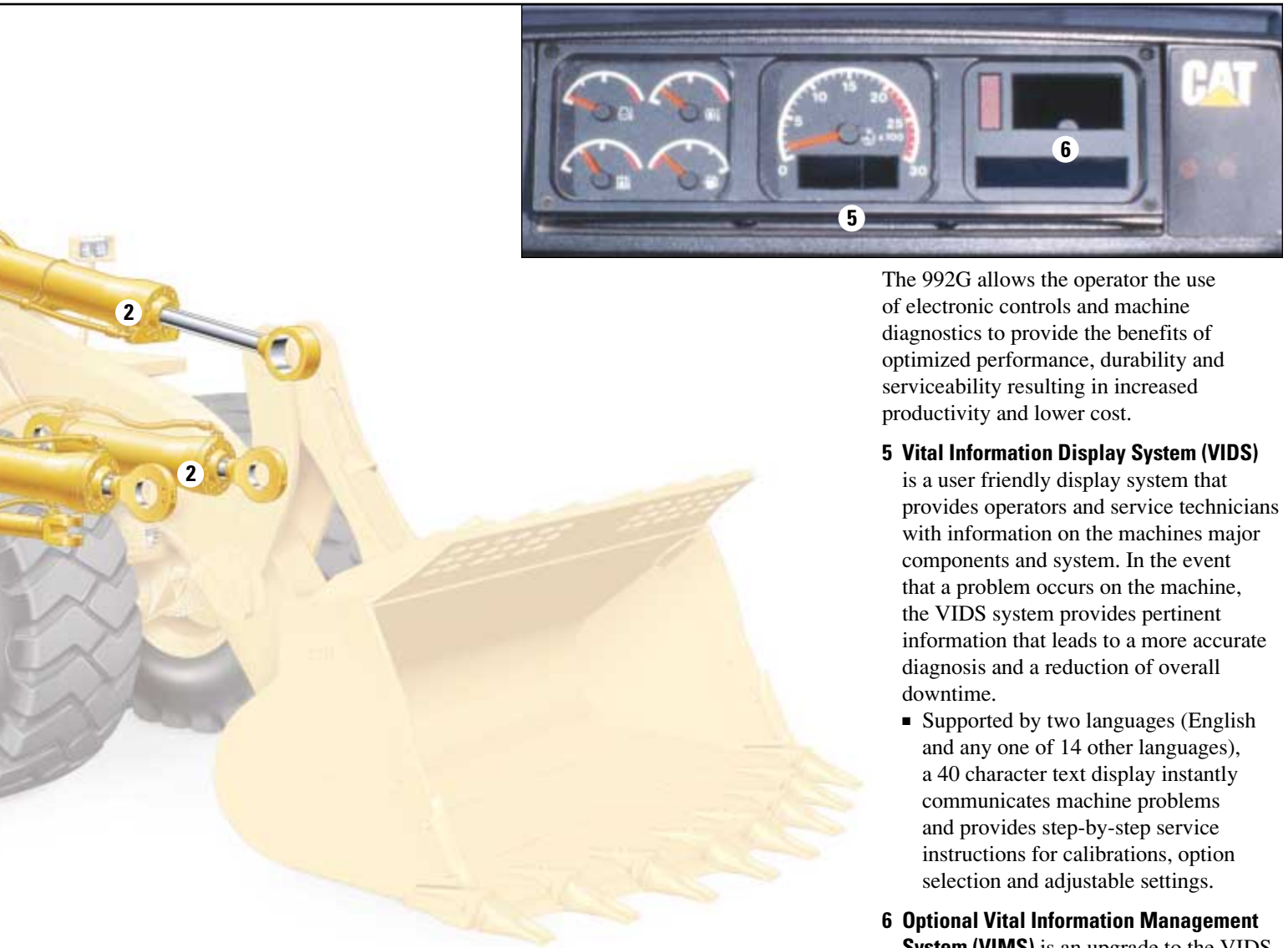

The 992G allows the operator the use of electronic controls and machine diagnostics to provide the benefits of optimized performance, durability and serviceability resulting in increased productivity and lower cost.

5 Vital Information Display System (VIDS)

is a user friendly display system that provides operators and service technicians with information on the machines major components and system. In the event that a problem occurs on the machine, the VIDS system provides pertinent information that leads to a more accurate diagnosis and a reduction of overall downtime.

- Supported by two languages (English and any one of 14 other languages), a 40 character text display instantly communicates machine problems and provides step-by-step service instructions for calibrations, option selection and adjustable settings.

6 Optional Vital Information Management System (VIMS)

is an upgrade to the VIDS system. Including all of the functionality of VIDS, VIMS includes additional machine management information with the capabilities of tracking, downloading and creating summary reports.

- **Payload Control System**, integrated into VIMS, offers on-the-go weighing to provide accurate payload measurements without slowing the operator.

Operator Station

Comfort and control – top quality operator station will help maximize productivity.

Spacious new cab design is 75 percent larger, incorporating innovations for operator comfort, maneuverability and productivity. Features include outstanding viewing, improved cab ventilation, interior sound levels below 75 dB(A), standard coat hook, cup holder, storage bin, intermittent wet-arm wipers, room for a large lunch cooler, and is radio-ready.

1 STIC control system provides a fluid motion that reduces effort and allows the operator to work the machine for long periods of time with little or no fatigue. Simple side-to-side motions of the operator's left arm turn the machine right or left. Transmission shifting forward, neutral and reverse is controlled by the operator's fingers, and gear selection is controlled by the operator's thumb.

2 Left brake pedal operates impeller clutch torque converter.

3 Contour Series Seat with air suspension and retractable seat belt is designed for comfort and support. Seat cushions reduce pressure on the lower back and thighs while allowing unrestricted arm and leg movement. The seat is six-way adjustable and the retractable seat belt remains off the floor and is easy to reach for the operator. Armrests are height and tilt adjustable.





4 Floor mounted Electro-hydraulic Controls and arm rests provide low effort, finger tip control for enhanced comfort and stability.

- Controls and arm rests are fore, aft, and height adjustable to accommodate operators of any size in a comfortable operating position.
- Levers send electrical signals to a pilot valve that controls movement of the linkage and bucket.

5 Vital Information Display System (VIDS) is the standard display system that provides information on the machine's major components and systems.

- Gauge Displays fuel tank level and temperatures for, engine coolant, power train and hydraulic oil. Tachometer is an analog gauge with digital readout for gear selection

6 Optional Vital Information Management System (VIMS) is an upgrade to the VIDS system that monitors additional components and includes Payload Control System.

7 Automatic kickouts for lift, lower, and bucket tilt are adjustable electronically from the cab.

8 Throttle Lock allows operator to preset the engine speed for a variety of applications, resulting in faster cycle times and increased productivity.

9 Rimpull Control System Switch turns RCS on and off.

10 Rimpull Control System (RCS) has four factory preset reduced rimpull settings (80, 65, 50 and 35 percent of rimpull).

11 Optional Ride Control Switch turns Ride Control on and off.

- **Optional Ride Control** attachment provides a boom suspension system by placing accumulators in the boom circuit, reducing fore and aft pitch over terrain. This results in a smoother, more comfortable ride allowing higher load and carry speeds, increased load retention and component life.

12 Quick Shift feature allows quicker cycle times by automatically shifting from 1st forward to 2nd reverse.

13 Improved viewing area. Bonded glass in the front window eliminates distracting metal frames and the narrow loader boom and single tilt cylinder provide excellent operator visibility to the bucket.

Buckets

Caterpillar buckets and Ground Engaging Tools provide the flexibility to match the machine to your application.

The 992G has several buckets available ranging in size from 11.5 m³ to 12.3 m³ that may be configured for a variety of impact and abrasive conditions. Additional bucket sizes are available depending on applications. All buckets are built with shell-tine construction (A) that resists twisting and distortion and feature replaceable, weld-on wear plates to protect the bottom of the bucket. Integral rock guard (B) helps retain big loads while standard floor liners (C) and heavy-duty pins and retainers (D) provide durability.

■ **Mechanically Attached Wear Plates (MAWP)** are available as a custom shop option.

1 Spade-Edge Rock Buckets with bolt-on segments are available in 11.5 m³ and 12.3 m³ sizes. Each accepts up to two sets of sidebar protectors (E), features shouldered, double-strap adapters, easily changed bolt-on segments (F) and several tip options to provide good performance and serviceability.

2 Heavy-duty Mining System is available as a 12.0 m³ capacity bucket. The system features independently attached edge and adapter covers (G), one set of sidebar protectors, and half radius liners (H). The heavy-duty mining system is recommended for high-abrasion in low to moderate impact conditions. Pin-on wear components reduce down-time associated with changing Ground Engaging Tool Components.

3 Heavy-duty Quarry Bucket is available as a 11.5 m³ capacity bucket and is recommended for use in face loading where moderate abrasion and high impact is encountered. This bucket features additional wear protection items, including: thicker base edge and adapters (I), additional liners and wear plates (J), bolt-on half arrow segments (K), and four sidebar protectors.

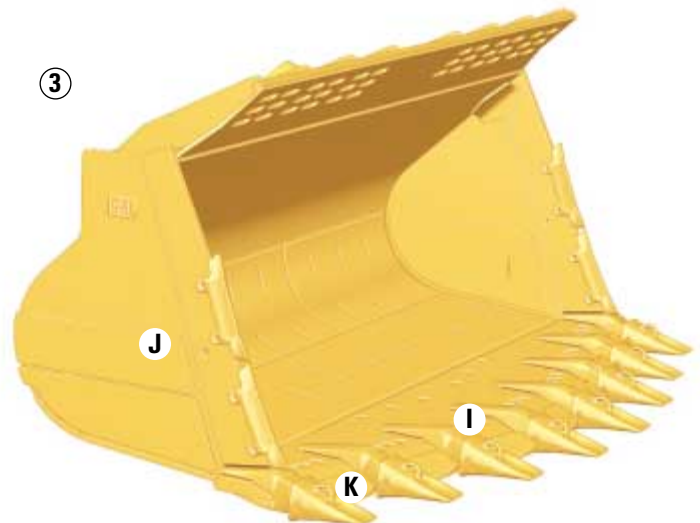
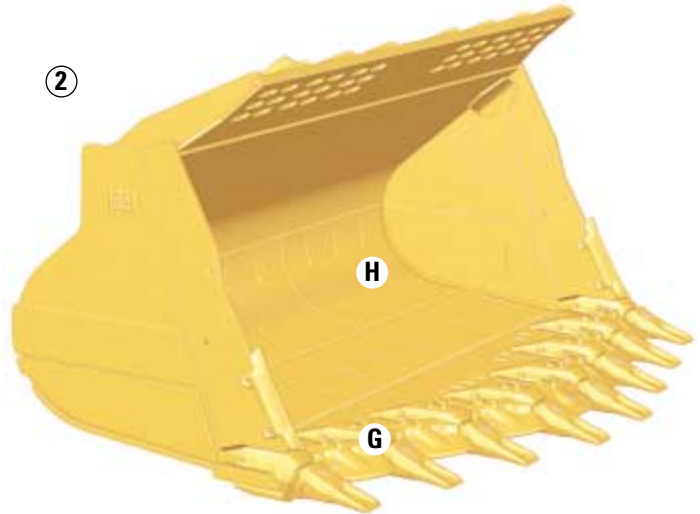
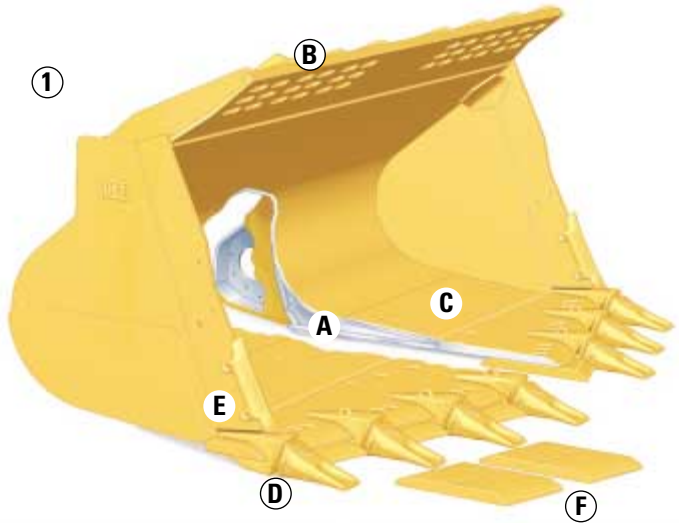

Bucket Match

Proper bucket and application match delivers increased stability and performance.

The 992G offers a variety of bucket sizes and available Ground Engaging Tool configurations to properly configure the machine based on material density, impact and abrasion.

Depending on your material densities, the 992G has available a 11.5 m³ Spade Nose bucket with bolt-on segments for improved performance and increased stability.

Increased full turn static tip load, horsepower and hydraulic capabilities allow the 992G to effectively utilize the 12.3 m³ bucket size in lighter materials such as limestone. All buckets on the 992G feature the well proven shell-tine construction.



Standard Bucket Selection Guide

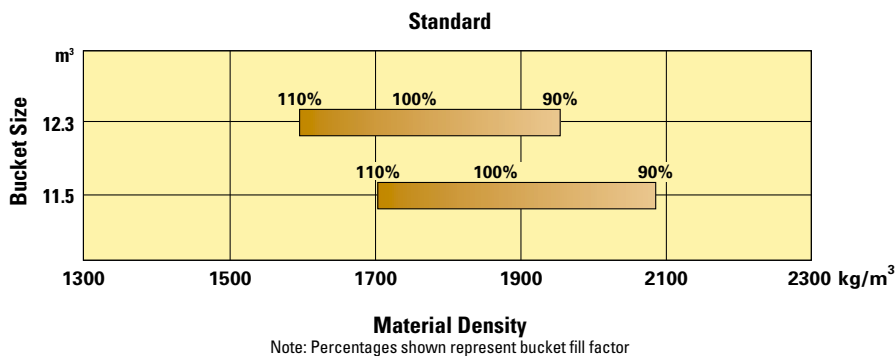

Application Truck Match

Matched payloads and matched buckets ensure optimum performance.

The 992G is an aggressive first gear loader for face and bank excavation. With increased dump clearance the 992G can easily load off-highway, 90 metric tons (100 ton) trucks in four passes. The 992G HL is an excellent six-pass match for 136 metric tons (150 tons) off highway trucks. Increased performance and good pass match make the 992G a versatile performer with a cost per ton that will help your bottom line.

We also designed the versatility of a material handler into the machine. With balanced rimpull and hydraulics and a full match torque converter, the 992G is an aggressive second gear loader. The job gets done quickly and efficiently in loose or stock-pile material and in load and carry work.



Large Wheel Loader/Truck Application Match

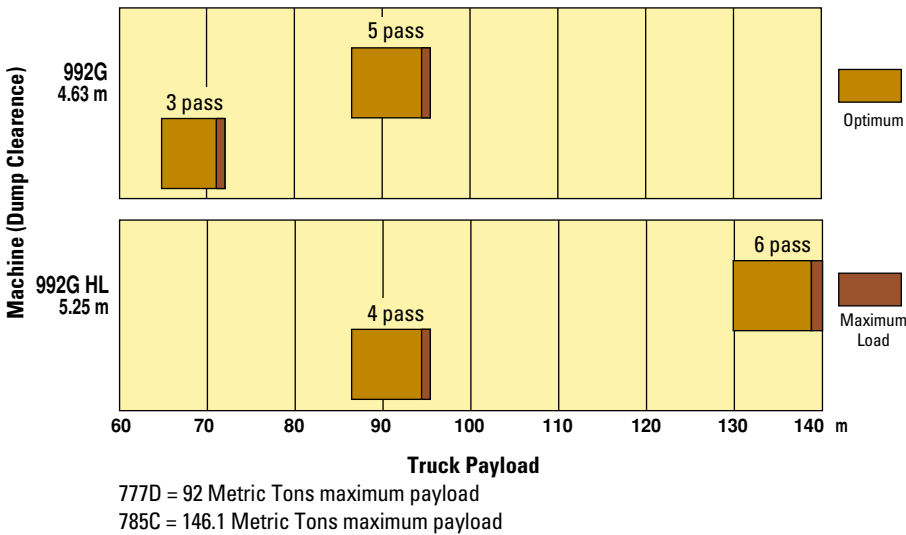

Serviceability

Less time spent on maintenance gives you more time on the job.

Easier maintenance and repair through monitoring key functions and logging critical indicators. Electronic diagnostic access is possible with a single tool, the Electronic Technician. In addition to the servicing features built into the engine, the 992G includes:

- Permanently sealed linkage joints are rebuildable and require minimal service.
- Vented dipsticks in linkage pins are easily accessible for checking and maintaining proper oil levels.
- The Advanced Modular Cooling System is easier to clean and maintain because it is isolated from the engine compartment.
- U-joints are lifetime lubricated, leaving the slip joint as the only drive line component needing grease.
- Lube points are centralized in accessible locations. Fuel fill is located in left hand bumper. Both lube points and fuel fill are accessible from ground level, making lube and fuel service quicker and easier.
- Swing-out doors on both sides of the engine compartment provide easy access to the engine oil dipstick and filler spout, fuel filters, air conditioner compressor, engine oil filters, alternator, starting receptacle, air filter service indicator, coolant fill, and ether starting aid. Disconnect switch and diagnostic connector are located on rear platform.
- Hinged doors in platform provide access to the hydraulic tank fill, implement and steering filters. Transmission dipstick and filler spout are serviced from the hitch area.



- Case drain filters are easily accessible for serviceability and are monitored by the optional VIMS system. For additional protection, high pressure screens are available as an optional attachment.
- Batteries sit in a built-in battery box and are accessible through tread plates on the platform.
- Shock resistant lights are replaceable by hand, not requiring the use of any tools.
- Vital Information Display System/Vital Information Management System provides operators and service technicians with vital diagnostic information on the machine's major components and systems.
- Diagnostic connector enables quick evaluation of eleven starting and charging functions.

Cat '5-Star Customer Service'

Your Cat 992G comes with something unique: Cat '5-Star Customer Service' from your Cat dealer.

Cat '5-Star Customer Service' means peace of mind from the minute you contact your Cat dealer. By building a partnership with your Cat dealer, you can focus on your business instead of your equipment.

Cat '5-Star Customer Service' brings together all the products, services and people from Caterpillar and the Cat dealer network and puts them firmly behind you. Count on them to help you maintain your competitive edge.

Cat '5-Star Customer Service' includes Equipment Management Services to help you make a better business decision. We'll assist you in selecting the right Cat equipment to suit your need, to optimize productivity. And we'll help you make smarter decisions, assist you with machine selection, purchasing or renting options, financing, and projected owning and operating costs.

Maintenance Services that enable you to maximize machine availability and performance. Every Cat dealer has a wide choice of maintenance products and services to make sure your equipment achieves maximum performance for the lowest possible cost.

Predictive Services to anticipate problems. By anticipating potential problems and preventing unscheduled repairs, Cat Predictive Services make sure that your equipment is always up and ready to run – because maximizing uptime means maximum earning capacity.



Reconditioning Services for a wider choice of repair alternatives. Caterpillar factory-reconditioned parts and components get your equipment back on the job in the minimum of time and with lower repair costs, contributing to reduced operating costs and a more efficient operation.

Off-the shelf availability of genuine Cat parts. Genuine parts, together with highly experienced, Cat-trained specialists make sure every repair is right first time and your machine is back earning its keep in the shortest possible time.



"Cat '5-Star Customer Service' is our commitment to combine outstanding equipment and services to give you the most cost effective solutions for your business."

Caterpillar and Cat dealers

Engine

Four-stroke cycle, eight cylinder 3508B EUI twin turbocharged and aftercooled diesel engine.

Ratings at 1750 rpm	kW	hp
Gross power ISO 3046-2	656	880

The following ratings apply at 1750 rpm when tested under the specific standard conditions for the specified standard:

Net Power	kW	hp
ISO 9249	597	800
EEC 80/1269	597	800

Max net torque	4218 Nm at 1300 rpm
Torque rise	30 percent

Dimensions

Bore	170 mm
Stroke	190 mm
Displacement	34.5 liters

Power rating conditions

- net power advertised is the power available when the engine is equipped with alternator, air cleaner, muffler and hydraulic fan drive
- no derating required up to 3050 m altitude

Features

- high pressure unit injection
- full electronic control
- two-piece piston with steel crown (three rings) and thermally isolated aluminum skirt
- copper-bonded crankshaft bearings
- hardened crankshaft journals
- two hard-faced inlet and exhaust valves per cylinder, valve rotators and hard alloy-steel seats
- self-aligning roller followers on cam shaft
- dry-type radial seal air cleaners with primary and secondary elements and precleaner
- direct-electric 24-volt starting system with 100-amp alternator and four 190-amp-hour, low-maintenance, high-output, 12-volt batteries

Transmission

533 mm planetary power shift transmission with three speeds forward and reverse.

Maximum travel speeds (45/65-45 tires)

Forward	km/h
1	6.7
2	11.9
3	20.2
Reverse	km/h
1	7.4
2	12.6
3	22.7

Features

- Electronic Shift Control
- self diagnostics accessible through Vital Information Display System
- Quick-shift feature
- speed and direction finger tip controls housed in STIC controller
- Impeller Clutch Torque Converter is standard with additional lock-up and free wheel stator feature available as an attachment
- Rimpull Control System

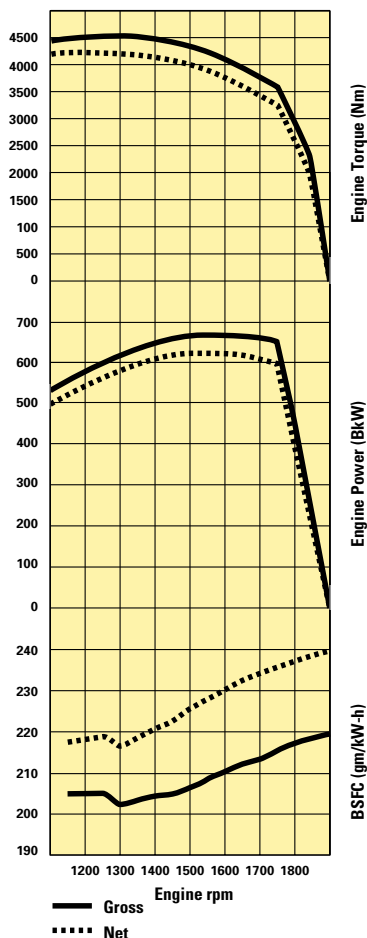

Brakes

Meets ISO 3450: 1992.

Parking brake features

- spring applied, oil-released, dry disc brake
- mounted on transmission transfer gear output shaft for manual operation
- electronic monitoring system alerts operator if transmission is engaged while parking brake is applied

Secondary brake features

- electronic monitoring system alerts operator if pressure drops and automatically applies the parking brake
- fully modulated

Service brake features

- four wheel, hydraulic, oil cooled, multiple-disc brakes
- completely enclosed
- modulated engagement without slack adjusters/adjustment free
- two brake pedals allow standard braking with right pedal and impeller clutch/braking with left pedal

Final Drives

All wheel drive.

Features

- planetary reduction at each wheel
- torque developed at the wheel, less stress on the axle shafts
- planetary units can be removed independently from the wheels and brakes

Axles

Fixed front, oscillating rear ($\pm 10^\circ$).

Features

- maximum single-wheel rise and fall: 630 mm
- conventional differential is standard
- free-floating axle shafts can be removed independently from wheels and planetary final drives
- axle oil cooling is standard on front and rear

Steering

Full hydraulic load sensing steering system meets ISO 5010: 1992 specified standards.

Features

- STIC operated pilot valve controls flow to steering cylinders
- center-point frame articulation
- front and rear wheels track
- hydraulic power with load-sensing system
- seat mounted and adjustable arm rests for a full range of adjustment for comfort
- side to side controller motion
- steering angle of 86° and one-hand operation

Loader Hydraulic System

System is completely sealed. Innovative low-effort controls.

Implement system with two pumps (1 fixed and 1 variable displacement)

Output at 1883 rpm and 31 000 kPa with SAE 10W oil at 66°C	452 lpm
Relief valve setting	31 000 kPa
Cylinders, double acting:	
lift, bore and stroke	279.4 x 1173 mm
tilt, bore and stroke	279.4 x 1816 mm

Pilot system, gear-type pump

Output at 1883 rpm and 2500 kPa	80 lpm
Relief valve setting (low idle)	2500 kPa

Hydraulic cycle time (standard)

Raise	9.12
Dump	3.26
Lower, empty, float down	3.47
Total	15.85 seconds

Features (standard)

- completely enclosed system
- low-effort, electro-hydraulic pilot-operated controls

Cab

Caterpillar cab with integrated Rollover Protective Structure (ROPS) are standard.

Features

- the operator sound exposure Leq (equivalent sound pressure level) measured according to the work cycle procedures specified in ISO 6396 is 75 dB(A), for the cab offered by Caterpillar, when properly installed and maintained and tested with the doors and windows closed
- the exterior sound pressure level for the standard machine measured at a distance of 15 meters as tested according to mid-gear-moving operation, is 82 dB(A)
- standard air conditioning system contains the environmentally safe R134a refrigerant
- ROPS meets the following criteria:
 - ISO 3471-1: 1986
 - ISO 3471: 1994
- Also meets the following criteria for Falling Objects Protective Structure:
 - ISO 3449: 1992 Level II
- ROPS structure is certified for 104 000 kg operating weight
- Spectator sound power level is 116 dB(A) as measured per ISO6395

Bucket Controls

Electro-hydraulic lift and tilt circuits.

Lift circuit features

- four positions: raise, hold, lower and float
- can adjust automatic kickout from cab

Tilt circuit features

- three positions: tilt back, hold, and dump
- can adjust automatic bucket positioner to desired loading angle from cab
- does not require visual spotting

Controls

- two-lever implement control
- electro-hydraulic bucket controls for lower lever efforts

Service Refill Capacities

	Liters
Fuel tank—standard	1562
Cooling system	
Jacket water	204
SCAC system	86
Crankcase	102
Transmission	169
Differentials and final drives	
front	360
rear	345
Hydraulic system	
implement and brakes	
(factory fill)	646
(tank only)	326
steering and engine	
(factory fill)	231
(tank only)	159

Operation/Bucket Specifications

		Standard Spade Edge		Large Standard Spade Edge		Light Aggregate Spade Edge		Heavy Duty Mining	
		Teeth and Segments		Teeth and Segments		Teeth and Segments		Teeth	
		Standard	High Lift	Standard	High Lift	Standard	High Lift	Standard	High Lift
Rated capacity	m ³	11.5	11.5	12.3	12.3	11.5	11.5	12.0	12.0
Struck capacity	m ³	9.39	9.39	10.1	10.1	9.45	9.45	9.86	9.86
Width	mm	4824	4824	4824	4824	4824	4824	4840	4840
Dump clearance at full lift and 45° discharge									
With teeth	mm	4636	5256	4636	5256	4574	5196	4623	5243
Bare	mm	5003	5623	5003	5623	5003	5623	5003	5623
Reach at full lift and 45° discharge									
With teeth	mm	2303	2299	2303	2299	2348	2337	2363	2358
Bare	mm	1699	1694	1699	1694	1699	1694	1729	1725
Reach with boom – horizontal and bucket level									
With teeth	mm	5105	5585	5105	5585	5163	5643	5186	5666
Bare	mm	4176	4657	4176	4657	4176	4657	4219	4700
Digging depth	mm	140	144	140	144	140	144	149	149
Overall length									
With teeth	mm	15 585	16 175	15 585	16 175	15 604	16 194	15 636	16 226
Bare	mm	15 143	15 733	15 143	15 733	15 143	15 733	15 143	15 733
Overall height with bucket at full raise	mm	9415	10 035	9415	10 035	9415	10 035	9415	10 035
Loader clearance circle with bucket in carry position									
With teeth	mm	22 272	22 876	22 272	22 876	22 272	22 876	22 310	22 918
Bare	mm	21 882	22 464	21 882	22 464	21 882	22 464	21 942	22 512
Static tipping load straight*	kg	58 469	56 432	58 130	56 095	56 422	54 403	57 692	55 661
Static tipping load at full 40° turn	kg	52 319	49 971	51 979	49 635	50 272	47 942	51 541	49 200
Static tipping load at full 43° turn	kg	51 146	48 799	50 806	48 443	49 099	46 750	50 368	48 008
Breakout force**	kN	652	637	644	630	635	621	642	627
Operating weight*	kg	93 779	97 544	94 113	97 879	95 796	99 562	94 545	98 311

Dimensions are measured to the tip of the bucket teeth to provide accurate clearance data. SAE Standards specifies the cutting edge.

* Static tipping load and operating weight shown are based on standard machine configuration with 45/65-45, 46 PR (L-5) tires, full fuel tank, coolant, lubricants and operator.

** Measured 102 mm: behind tip of segments with bucket hinge pin as pivot point not in accordance with SAE J732C.

Dimensions

All dimensions are approximate.

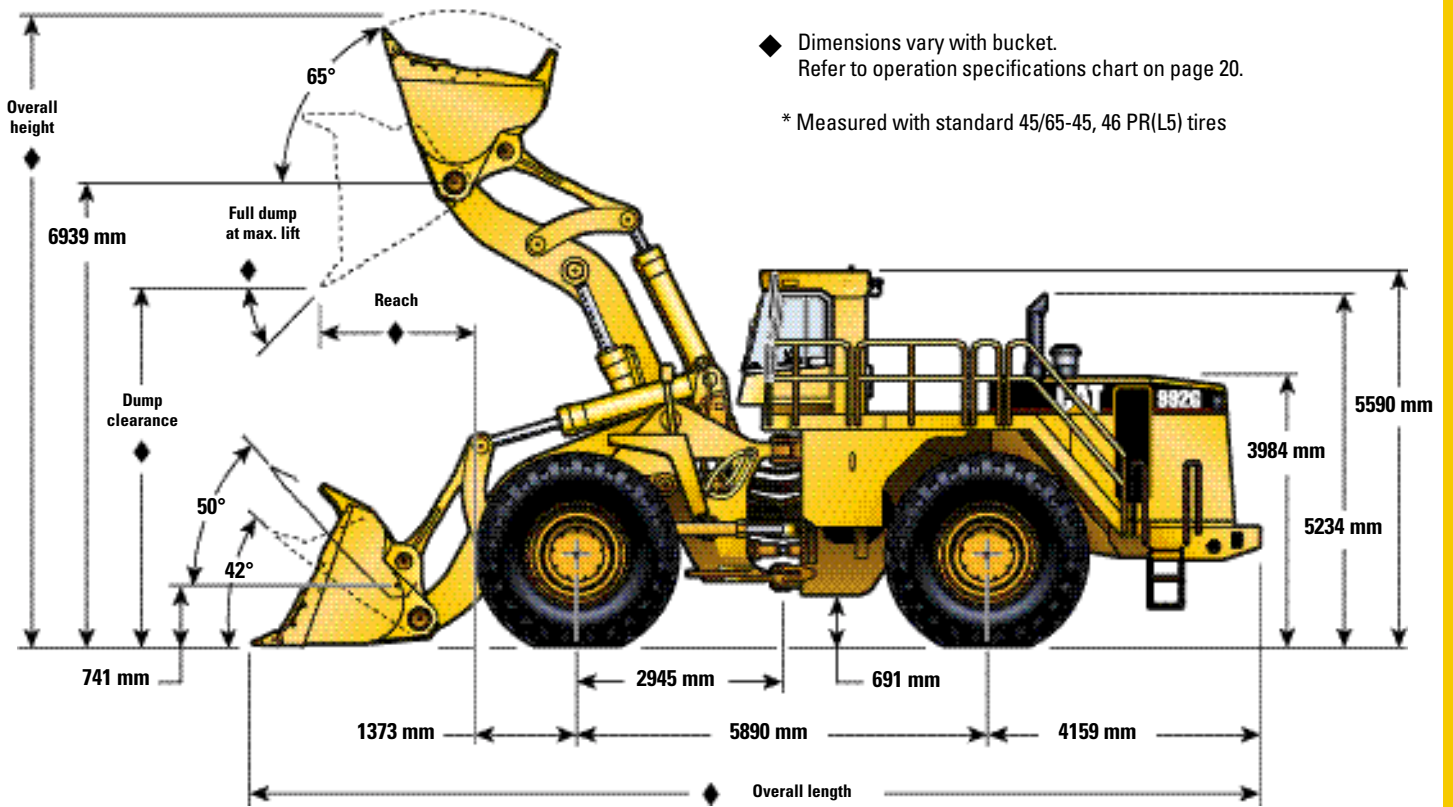

Tire Dimensions/Specifications

	Width over tires mm	Ground clearance mm	Change in vertical dimensions mm
45/65, 46 ply L-5 Firestone	4516	691	0
45/65, 46 ply L-5 General	4475	679	12
45/65, 46 ply L-5 Goodyear	4495	671	20
45/65, 50 ply L-5 Firestone	4516	691	0
45/65, 50 ply L-5 General	4475	679	12
45/65, 50 ply L-5 Bridgestone	4493	632	59
45/65-45, 58 ply L-5 Bridgestone	4493	632	59
45/65-45, 58 ply NRL 6J L-5 Goodyear	4534	622	69
45/65 R45 1* L-5 Bridgestone	4572	581	110
45/65 R45 1* VSDL L-5 Bridgestone	4572	581	110
45/65 R45, RL4 Goodyear	4557	596	95
45/65 R45, RL5 Goodyear	4557	596	95
45/65 R45, 1* L-4 (XLDD1) Michelin	4519	621	70
45/65 R45, 1*L-5 (XLDD2) Michelin	4519	619	72
45/65 R45, 1* L-5 (X MINED2) Michelin	4476	629	62

Note: In certain applications (such as load-and-carry work) the loader's productive capabilities might exceed the tires tonnes-km/h capabilities. Caterpillar recommends that you consult a tire supplier to evaluate all conditions before selecting a tire model. Other special tires are available on request.

Supplemental Specifications

Tires	Change in Operating Weight standard (for four tires)	Change in Articulated Static Tipping Load	
	kg	Standard	High Lift
	kg	kg	kg
45/65, 46 ply L-5 Firestone	0	0	0
45/65, 46 ply L-5 General	+ 427	+ 284	+ 554
45/65, 46 ply L-5 Goodyear	- 162	- 108	- 97
45/65, 50 ply L-5 Firestone	-278	-185	-164
45/65, 50 ply L-5 General	+441	+293	+260
45/65, 50 ply L-5 Bridgestone	-423	-278	-248
45/65-45 58 ply L-5 Bridgestone	-91	-60	-53
45/65-45 58 ply NRL 6J L-5 Goodyear	-1055	-694	-620
45/65 R45 1H L-5 Bridgestone	-1327	-872	-780
45/65 R45 1H VSDL L-5 Bridgestone	-1327	-872	-780
45/65 R45 RL4K Goodyear	-1123	-737	-660
45/65 R45 RL5K Goodyear	-1307	-859	-768
45/65 R45 1H L-4 (XLDD1) Michelin	- 1942	- 1290	- 1142
45/65 R45 1H L-5 (XLDD2) Michelin	- 681	- 452	- 400
45/65 R45 1H L-5 (XMINED2) Michelin	+ 752	+ 523	+ 451

Standard Equipment

Standard and optional equipment may vary. Consult your Caterpillar dealer for specifics.

Electrical

100-ampere alternator
12-volt electrical converter (for radio)
24-volt electrical system
Electric starter (heavy-duty)
External lighting system (front and rear)
Maintenance-free batteries
Starting and charging system diagnostic connector
Starting receptacle for emergency starting

Operator Environment

Air Conditioner
Air suspension seat
Cigarette lighter and ashtray
Coat hook
Dome light (cab)
Electric horn
Electro-hydraulic implement controls
External two-post ROPS structure
Heater and defroster
Implement system lock
Mirrors, Rearview Outboard
Monitoring system (Vital Information Display System)
Action alert system, three-category
Gauges:
 tachometer
 fuel level
 hydraulic oil temperature
 transmission oil temperature
 engine coolant temperature
Radio-ready cab for entertainment or two-way radio (three-point mounting)
Rearview mirrors (interior and exterior mounted)
Retractable seat belt 76 mm wide
Sound-suppressed pressurized ROPS cab
STIC Control System
Sunshade/visor, front and rear
Tinted glass
Transmission gear indicator
Wet-arm wiper/washers (front, rear and corner)

Power Train

Axle oil-coolers
Advanced Modular Cooling System (AMOCS) radiator
Automatic planetary power shift transmission with 3F/3R speed range control
Case drain filtration
Cat 3508B EUI Direct Injected Diesel Engine with 24-volt direct electric starting system
Demand fan
Engine air intake precleaner
Fuel priming aid
Full hydraulic, enclosed, wet multiple disc service brakes and parking/secondary
Impeller Clutch Torque Converter with rimpull control device
Separated cooling system
Sound suppressed muffler
Swing-out cooler cores
Throttle lock

Other Standard Equipment

Adjustable automatic bucket positioner
Adjustable from cab automatic lift/tilt kickouts
Backup Alarm
Counterweight
Drawbar hitch with pin
Fenders (front and rear)
Guards, Crankcase
Hydraulic oil cooler
Lighting, general purpose (four)
Locking engine enclosures
Muffler
Oil change, high speed
Rear Access Stairs
Vandalism protection caplocks

Tires

Several tire options are available

Optional Equipment

Optional equipment may vary. Consult your Caterpillar Dealer for specifics.

Autolube, Lincoln
Battery, 4D gel
Deluxe filtration, high pressure screens
Fuel, fast fill
Fuel heater
Heater, engine coolant, 120-volt
Heater, engine coolant, 240-volt

High Ambient Radiator
High Lift Arrangement
Lock-up clutch
Precleaner, Turbine non-metal
Ride control
Right hand stairway
Secondary steering
VIMS Monitoring System

992G Wheel Loader

HEHL5182-2 (04/2000) ho

Featured photos of machines may not always include standard equipment.
See your Caterpillar Dealer for available options.
Materials and specifications are subject to change without notice.

www.cat.com

© 2000 Caterpillar

CATERPILLAR[®]