

185-200 NET HORSEPOWER



JOHN DEERE

J

DOZER

850J WASTE HANDLER



Purpose-built for handling waste.

850J Waste Handler Outside Dozer with Semi-U Blade

WT undercarriage

185 net hp Tier 3 diesel

7.62-cu.-yd. capacity

14.5-cu.-yd. capacity with trash rack

44,261-lb. operating weight

LGP undercarriage

200 net hp Tier 3 diesel

7.8-cu.-yd. capacity

15.2-cu.-yd. capacity with trash rack

48,263-lb. operating weight



With their full-featured hydrostatic drive-trains, 850J Waste Handlers deliver production-boosting advantages you just don't get with other crawlers in this class. But powerful performance is just the start of the 850J WH story. These 24-ton workhorses

also have what they need to keep their cool in a hostile world. They're purpose-built to be as waste-proof and easy to maintain as possible. With the 850J Waste Handler, you get the productivity and uptime you need for landfill work.

850J Waste Handler with PAT Blade

WLT undercarriage

185 net hp Tier 3 diesel
5.57-cu.-yd. capacity
12.7-cu.-yd. capacity with trash rack
47,182-lb. operating weight

LGP undercarriage

200 net hp Tier 3 diesel
5.87-cu.-yd. capacity
12.9-cu.-yd. capacity with trash rack
48,527-lb. operating weight



Designed and built with extensive input from solid-waste professionals like you, these crawlers are rugged and reliable performers.

For work in the waste pile, equip your 850J WH with an outside-mount semi-U blade and optional trash rack.

For cover and slope work with occasional waste-pile use, opt for the inside-mount PAT blade with optional trash rack.

The reversing fan can be set to change direction every 30, 60, or 90 minutes, or activated from the seat as needed. Keeps the engine running cool and increases productivity.

Variable-speed fan automatically speeds up or slows down, running only as needed to keep things cool. Improves fuel efficiency and decreases noise levels, too.

Unitized mainframe with flush-fit bottom guards combines with tight-fitting side shields to prevent debris from being drawn into the engine compartment.

Generous air intake through the engine compartment slows the velocity and reduces vacuuming of debris. Right and left side shields open wide for easy access.

1. With the fan positioned just behind the heavy-duty grille, coolers are less vulnerable to damage. Split-hinged grille opens wide for convenient clean-out.
2. Five-millimeter perforations in the hood and side shields act as a "first filter," preventing entry of most airborne debris.
3. Six-fin-per-inch side-by-side radiator and coolers resist clogging and are easy to clean.





Cool productivity.

These waste handlers are built to run cool regardless of what's in the air or underfoot. Their highly effective cooling system design employs a hydraulic-driven variable-speed fan that helps

preserve power and precious fuel. The fan automatically reverses to help shed waste and debris from cooler cores and side screens. So your operators can work hard without breaking a sweat.



Unyielding.

You won't have to worry about these waste handlers getting trashed too soon. Engineers started with highly reliable 850J Dozers, then added what was needed to help them survive,

even thrive in, the daily grind of landfill work. Anything that was susceptible to damage has been sealed, rerouted, or re-engineered all in the name of uptime.



Four forward and three rear high-intensity halogen work lights are positioned high for superior illumination.

Lift-cylinder guards keep hydraulic hoses and cylinders out of danger. Blade hoses are steel-cable supported and Cordura covered for extra protection. Semi-U blade hoses are routed internally for extra protection and to prevent snagging.

Air-conditioning condenser is mounted up and away behind the cab for extra protection and dust reduction.

Cantilevered carrier rollers, recessed segmented sprockets, and trapezoidal openings in extreme-duty track shoes help prevent refuse packing.

Uni-body track frames ensure durability. Smooth idler-to-sprocket covers shed material build-up for easier clean-out.

Sealed electrical center protects fuses, relays, and connections from dirt, debris, and moisture, ensuring maximum reliability and uptime.

Optional full-width trash rack reduces front-end damage and increases blade capacity for extra production.

Cab-mounted strobe light is activated whenever the electrical system is switched on.

The curved shape of the final drive housings resists wrapping and sawing action of debris.

1. Heavy-duty tank guards help protect the hydraulic, hydrostatic, and fuel reservoirs. Optional front and rear striker bars help shed material from the tracks.
2. Unitized mainframe with flush-fit bottom guards forms a smooth underbelly that doesn't accumulate or drag trash.



Final Drive Protection:

- A) Final drive seal guard
- B) Final drive seal guard
- C) Stepped labyrinth protection
- D) Protected final drive seals

Bolt-on seal guards and stepped labyrinth housings make the final drives virtually impenetrable. They help minimize downtime and expense by keeping wire, strapping tape, metal springs, and other intrusive contaminants away from final drive seals.

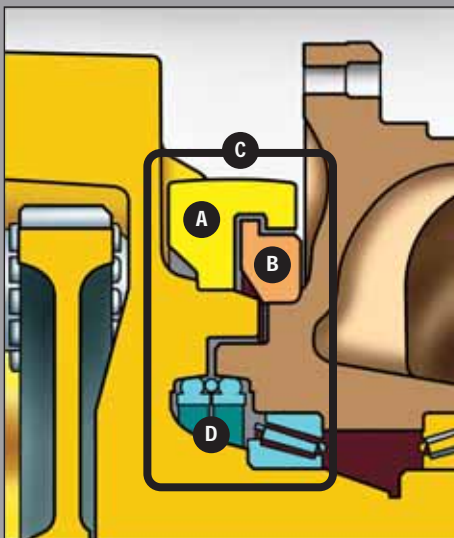

Uncover new ways to keep costs down.

Swing open their hinged side shields and you'll uncover lots of ways these crawlers help keep maintenance and daily operating costs to a minimum. Same-side daily service points make quick work of the daily routine, and extended engine oil and

drivetrain service intervals let you work longer between changes. Other uptime-enhancing features include an easy-to-clean undercarriage, quick-to-replace hydraulic hoses, and designed-in diagnostics, to list just a few.

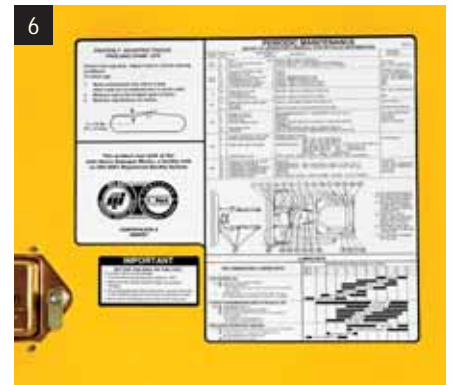
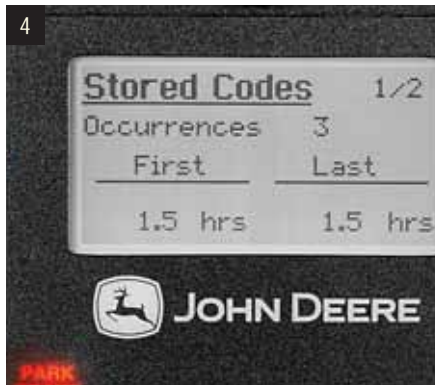

1. Operator station tilts a full 70 degrees in only minutes for wide-open access to internal components.
4. Advanced in-cab monitor gives easy-to-understand diagnostic messages for quick and easy troubleshooting without special tools.

2. Common hydraulic and hydrostatic filters and engine, hydraulic, and transmission oil simplify service and minimize expense.
5. Rotary air pre-cleaner ejects dust to maximize filter life and includes a trash guard to prevent debris entry.

3. Fluid sample and remote drive-system test ports simplify preventative maintenance and troubleshooting for increased uptime.
6. Convenient maintenance and lube chart provides a quick reference to help ensure that nothing gets overlooked.

Five-hundred-hour engine oil and 2,000-hour transmission and hydraulic fluid levels increase uptime, decrease expense.

Hinged bottom guard opens easily for quick and convenient clean-out.

Greaseless center crossbar pin joint provides long life with less maintenance. Lube bank provides easy access to C-frame pivots.

Separate hydraulic and hydrostatic reservoirs eliminate the possibility of cross-contamination. Sight gauges reveal fluid levels at a glance.

Unlike elevated tracks, Deere's heavy-duty sealed and lubricated Dura-Trax™ undercarriage has only one wear-causing forward-travel flex point — for longer life.



Same-side daily service points make quick work of the daily routine.



Tireless performer.

If you're looking for a crawler that does more with less effort, you'll choose a John Deere. The 850J's hydrostatic system goes beyond the limits of other drivetrains, delivering infinite speed control, power management, and full

power turns. What's more, Total Machine Control lets an operator customize machine operation and response to personal preferences. For nearly tireless operating ease that helps make big productivity possible.



Generous hydraulic flow and precise metering ensure powerful and quick blade response.

Power management takes the work out of efficient operation, automatically powering up or down as loads change to maintain peak engine efficiency.

Spacious, pressurized, air-conditioned cab employs two easy-to-service filters and numerous directional vents to deliver a comfortable work environment.

Seven-way adjustable deluxe suspension armchair provides plenty of legroom and daylong comfort.

A convenient 12-volt port powers cell phones and other accessories.



Ergonomically correct joystick provides intuitive, low-effort control of steering, forward/reverse travel, and ground speed.



Exclusive TMC lets an operator select decelerator mode and response, forward/reverse ground-speed ranges, steering modulation, F-N-R shift rate, and forward/reverse ratios for one-of-a-kind control.

Specifications

Engine	850J WH WT w/Semi-U Blade / WLT w/PAT Blade	850J WH LGP w/PAT or Semi-U Blade
Manufacturer and Model	John Deere PowerTech Plus™ 6090HT	John Deere PowerTech Plus 6090HT
Non-Road Emission Standards	certified to EPA Tier 3 regulations	certified to EPA Tier 3 regulations
Cylinders	6	6
Displacement	550 cu. in. (9.0 L)	550 cu. in. (9.0 L)
Net Power (ISO9249)	185 hp (137 kW) @ 1,800 rpm	200 hp (151 kW) @ 1,800 rpm
Net Peak Torque (ISO9249)	611 lb.-ft. (831 Nm) @ 1,500 rpm	675 lb.-ft. (915 Nm) @ 1,500 rpm
Lubrication	pressure system with full-flow spin-on filter and oil-to-water cooler	pressure system with full-flow spin-on filter and oil-to-water cooler
Air Cleaner	dual-stage dry type with tangential unloader	dual-stage dry type with tangential unloader
Cooling		
Type	variable-speed, thermostatically controlled; hydraulically driven with auto reverser on selectable timer or activated by a switch in the cab	
Engine Coolant Rating	- 34 deg. F (- 37 deg. C)	- 34 deg. F (- 37 deg. C)
Powertrain		
Transmission	automatic, dual-path, hydrostatic drive; load-sensing feature automatically adjusts speed and power to match changing load conditions; each individually controlled track is powered by a variable-displacement piston pump and motor combination; ground-speed selection buttons on single-lever steering and direction control; independently selectable reverse speed ratios 80%, 100%, 115%, or 130% of forward ground speed; decelerator pedal controls ground speed to stop	
System Relief Pressure	6,650 psi (45 850 kPa)	6,650 psi (45 850 kPa)
Filter, Charge Oil	10 micron	10 micron
Cooling	oil-to-air	
Travel Speeds (forward and reverse)	6.3 mph (10 km/h)	6.3 mph (10 km/h)
Steering	single-lever steering, speed, direction control, and counterrotation; full power turns and infinitely variable track speeds provide unlimited maneuverability and optimum control; hydrostatic steering eliminates steering clutches and brakes	
Final Drives	double-reduction planetary final drives transfer torque loads over three gear sets; mounted independently of track frames and dozer push frames for isolation from shock loads	
Total Ratio	44.7483 to 1	44.7483 to 1
Drawbar Pull		
Maximum	77,300 lb. (344 kN)	77,300 lb. (344 kN)
@ 1.2 mph (1.9 km/h)	37,500 lb. (167 kN)	40,000 lb. (178 kN)
@ 2.0 mph (3.2 km/h)	27,000 lb. (120 kN)	29,500 lb. (131 kN)
Service Brakes	hydrostatic (dynamic) braking stops the machine when the direction/steering control lever is moved to neutral or the decelerator is depressed to the end of travel	
Type	hydraulic	
Parking Brakes	exclusive safety feature engages wet, multiple-disc brakes whenever the engine stops, the decelerator is depressed to the end of travel, or the park lock lever is placed in the start or neutral positions and motion is detected; machine cannot be driven with brake applied, reducing wear-out or need for adjustment; spring-applied, hydraulic release	

Hydraulics**850J WH WT w/Semi-U Blade / WLT w/PAT Blade / LGP w/PAT or Semi-U Blade**

Load sense, piston pump	
Pump (74 cc)	46 gpm (174 L/min.)
System Relief Pressure	3,625 psi (24 993 kPa)
Differential Pressure	275 psi (1896 kPa)
Filter, Return Oil	10 micron
Maximum Flow @ Unloaded High Idle	43 gpm (163 L/min.)
Control	
Outside Dozer	T-bar hydraulic-pilot two-function joystick
PAT	T-bar hydraulic pilot two-function joystick with push-button angle function
Cooling	convective oil sump

Electrical

Battery Capacity	950 CCA
Reserve Capacity	190 min.
Alternator Rating (cab)	80 amp
Waste-Handler Dozer Lights	7 total: cab roof mounted (4), cab rear mounted (1), grille or lift cylinder mounted (2), and rear reflectors (2)

Undercarriage**850J WH WT w/Semi-U Blade / WLT w/PAT Blade****850J WH LGP w/PAT or Semi-U Blade**

Tracks	John Deere Dura-Trax™ features deep-heat-treated, sealed, and lubricated track links and through-hardened, sealed, and lubricated rollers for maximum wear resistance; sprockets are segmented			
	<i>WT with semi-U blade</i>	<i>WLT with PAT blade</i>	<i>LGP with PAT blade</i>	<i>LGP with semi-U blade</i>
Track Gauge for WT Waste Handler	6 ft. 8 in. (2032 mm)	7 ft. 4 in. (2235 mm)	7 ft. 10 in. (2388 mm)	7 ft. 2 in. (2184 mm)
Grouser Width (single bar, open center)	30 in. (762 mm)	30 in. (762 mm)	36 in. (914 mm)	36 in. (914 mm)
Shoes (each side)	40	45	45	45
Track Rollers (single flange, each side)	7	8	8	8
Track Length on Ground	9 ft. 1 in. (2769 mm)	10 ft. 9 in. (3284 mm)	10 ft. 9 in. (3284 mm)	10 ft. 9 in. (3284 mm)
Ground Contact Area	6,540 sq. in. (42 193 cm ²)	7,758 sq. in. (50 052 cm ²)	9,310 sq. in. (60 064 cm ²)	9,310 sq. in. (60 064 cm ²)
Ground Pressure	6.83 psi (47.1 kPa)	6.11 psi (42.2 kPa)	5.15 psi (35.5 kPa)	5.16 psi (35.6 kPa)
Track Pitch	8 in. (203 mm)	8 in. (203 mm)	8 in. (203 mm)	8 in. (203 mm)
Oscillation at Front Roller	± 4.5 in. (± 114 mm)	± 6.5 in. (± 166.5 mm)	± 6.6 in. (± 168 mm)	± 6.6 in. (± 168 mm)

Serviceability**850J WH WT w/Semi-U Blade / WLT w/PAT Blade / LGP w/PAT or Semi-U Blade**

Refill Capacities*	
Fuel Tank with Lockable Cap	98 gal. (371 L)
Cooling System with Recovery Tank	9.2 gal. (35 L)
Engine Oil with Filter	7 gal. (26 L)
Transmission Reservoir with Filter	27.9 gal. (106 L)
Hydrostatic Reservoir and Filter	27.9 gal. (106 L)

*Please follow drain and refill procedures and volumes listed in the operator's manual.

Operating Weights**850J WH WT w/Semi-U Blade / WLT w/PAT Blade****850J WH LGP w/PAT or Semi-U Blade**

With Waste-Handling Package, Blade with Trash Rack, Full Fuel Tank, and 175-lb. (79 kg) Operator	<i>WT with semi-U blade</i>	<i>WLT with PAT blade</i>	<i>LGP with PAT blade</i>	<i>LGP with semi-U blade</i>
With Extreme-Duty Shoes With Trapezoidal Holes				
30 in. (762 mm)	44,665 lb. (20 260 kg)	47,432 lb. (21 515 kg)		
36 in. (914 mm)			48,906 lb. (22 183 kg)	48,796 lb. (22 133 kg)
Blade With Trash Rack and Push-Beam Weights				
Including Straight End Bits	7,486 lb. (3396 kg)	N/A	N/A	7,644 lb. (3467 kg)
C-Frame Assembly with Cylinder	N/A	7,024 lb. (3186 kg)	7,198 lb. (3265 kg)	N/A

Operating Weights <i>(continued)</i>	850J WH WT w/Semi-U Blade / WLT w/PAT Blade	850J WH LGP w/PAT or Semi-U Blade		
Optional Components <i>(add or subtract from base weight)</i>				
	<i>WT with semi-U blade</i>	<i>WLT with PAT blade</i>	<i>LGP with PAT blade</i>	<i>LGP with semi-U blade</i>
22-in. (560 mm) Extreme-Duty	- 482 lb. (- 218.6 kg)	- 482 lb. (- 218.6 kg)		
24-in. (610 mm) Extreme-Duty	- 148 lb. (- 67.1 kg)	- 148 lb. (- 67.1 kg)		
30-in. (760 mm) Extreme-Duty			- 1,102 lb. (- 500 kg)	- 1,102 lb. (- 500 kg)
Trash Rack	455 lb. (206.4 kg)	436 lb. (197.8 kg)	462 lb. (209.6 kg)	498 lb. (225.9 kg)
Striker Bars				
Front	245 lb. (111.1 kg)	160 lb. (72.6 kg)	160 lb. (72.6 kg)	325 lb. (147.4 kg)
Rear	366 lb. (166 kg)	171 lb. (77.6 kg)	171 lb. (77.6 kg)	171 lb. (77.6 kg)
Air Pre-Cleaner				
Powered Cab	47 lb. (21.3 kg)	47 lb. (21.3 kg)	47 lb. (21.3 kg)	47 lb. (21.3 kg)
Dual-Stage Engine	13 lb. (5.9 kg)	13 lb. (5.9 kg)	13 lb. (5.9 kg)	13 lb. (5.9 kg)
Retrieval Hitch	114 lb. (52 kg)	114 lb. (52 kg)	114 lb. (52 kg)	114 lb. (52 kg)
Drawbar (extended rigid)	286 lb. (130 kg)	286 lb. (130 kg)	286 lb. (130 kg)	286 lb. (130 kg)
Screens				
Front and Door	175 lb. (79 kg)	175 lb. (79 kg)	175 lb. (79 kg)	175 lb. (79 kg)
Rear	75 lb. (34 kg)	75 lb. (34 kg)	75 lb. (34 kg)	75 lb. (34 kg)
Side	120 lb. (54 kg)	120 lb. (54 kg)	120 lb. (54 kg)	120 lb. (54 kg)
Condenser Guard	121 lb. (55 kg)	121 lb. (55 kg)	121 lb. (55 kg)	121 lb. (55 kg)
Limb Risers	600 lb. (272 kg)	600 lb. (272 kg)	600 lb. (272 kg)	600 lb. (272 kg)
Counterweight				
Front	875 lb. (397 kg)	875 lb. (397 kg)	875 lb. (397 kg)	875 lb. (397 kg)
Rear	990 lb. (449 kg)	990 lb. (449 kg)	990 lb. (449 kg)	990 lb. (449 kg)

Machine Dimensions

	<i>WT with semi-U blade</i>	<i>WLT with PAT blade</i>	<i>LGP with PAT blade</i>	<i>LGP with semi-U blade</i>
A Overall Height to Roof	10 ft. 5 in. (3175 mm)	10 ft. 5 in. (3175 mm)	10 ft. 5 in. (3175 mm)	10 ft. 5 in. (3175 mm)
B Tread Depth with Extreme-Duty Single- Bar Grousers	2.8 in. (71 mm)	2.8 in. (71 mm)	2.8 in. (71 mm)	2.8 in. (71 mm)
C Ground Clearance with Grousers (excludes grouser height)	16.1 in. (409 mm)	16.1 in. (409 mm)	16.1 in. (409 mm)	16.1 in. (409 mm)
With Trash Rack				
D Blade Width	11 ft. 8 in. (3556 mm)	13 ft. 2 in. (4013 mm)	14 ft. 0 in. (4267 mm)	12 ft. 8 in. (3861 mm)
E Blade Height				
With Trash Rack	6 ft. 6 in. (1981 mm)	6 ft. 0 in. (1829 mm)	6 ft. 0 in. (1829 mm)	6 ft. 4 in. (1930 mm)
Without Trash Rack	4 ft. 6 in. (1374 mm)	4 ft. 0 in. (1229 mm)	4 ft. 0 in. (1229 mm)	4 ft. 4 in. (1321 mm)
F Blade Lift Height	3 ft. 9 in. (1151 mm)	3 ft. 6 in. (1072 mm)	3 ft. 6 in. (1072 mm)	3 ft. 9 in. (1151 mm)
G Blade Digging Depth	23.6 in. (599 mm)	27.7 in. (704 mm)	28 in. (704 mm)	24 in. (599 mm)
H Blade Tilt (uses tilt jack)	29.6 in. (752 mm)	21.2 in. (538 mm)	23 in. (572 mm)	34 in. (853 mm)
I Overall Length with Blade	17 ft. 8 in. (5385 mm)	18 ft. 10 in. (5728 mm)	18 ft. 10 in. (5728 mm)	19 ft. 6 in. (5944 mm)
J Overall Width with Blade Angled	N/A	9 ft. 6 in. (2896 mm)	12 ft. 10 in. (3901 mm)	N/A
K Blade Angle	N/A	23.8 deg.	23.8 deg.	N/A
L Cut Reach	N/A	5.7 in. (145 mm)	4.3 in. (108 mm)	N/A
M Width Over Track	9 ft. 2 in. (2794 mm)	9 ft. 10 in. (2997 mm)	10 ft. 10 in. (3302 mm)	10 ft. 2 in. (3099 mm)
Blade Capacity				
With Trash Rack	14.5 cu. yd. (11.09 m ³)	12.7 cu. yd. (9.71 m ³)	12.9 cu. yd. (9.86 m ³)	15.2 cu. yd. (11.62 m ³)
Without Trash Rack	7.62 cu. yd. (5.82 m ³)	5.57 cu. yd. (4.26 m ³)	5.87 cu. yd. (4.49 m ³)	7.8 cu. yd. (5.96 m ³)

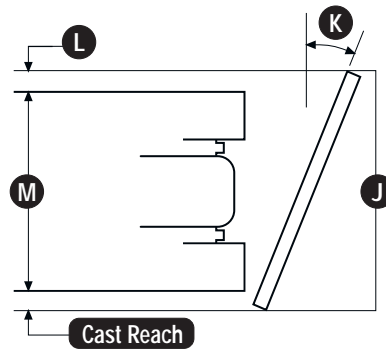
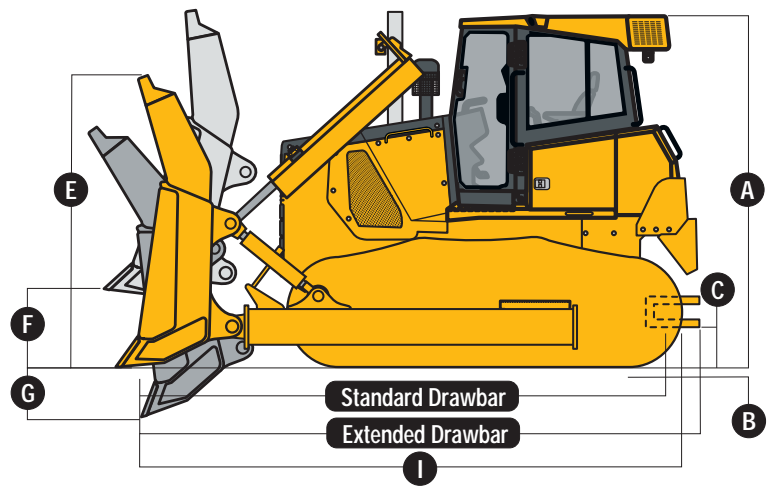
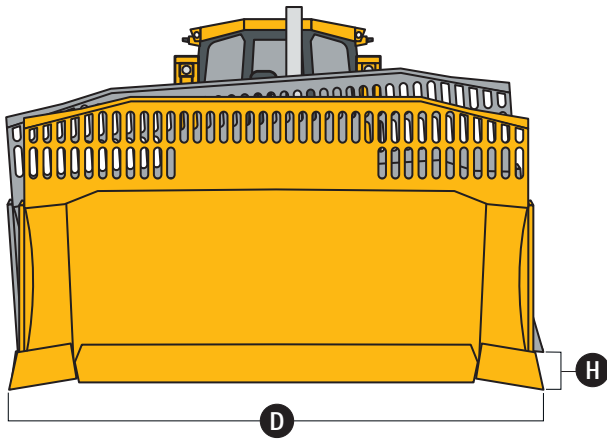

Rear Ripper

850J WH WT w/Semi-U Blade / WLT w/PAT Blade / LGP w/PAT or Semi-U Blade

- Parallelogram ripper with hydraulic pitch adjustment and ESCO ripper tips, multi-shank (3)
- Weight 4,480 lb. (2032 kg)
 - N** Maximum Penetration 28.5 in. (724 mm)
 - O** Maximum Clearance Under Tip 24 in. (610 mm)
 - P** Overall Length (lowered position) 5 ft. 4 in. (1626 mm)
 - P'** Overall length (raised position) 5 ft. 0 in. (1524 mm)
 - Q** Overall Beam Width 7 ft. 10.5 in. (2400 mm)
 - R** Slope Angle (full raise) 24 deg.
 - S** Ripping Width 7 ft. 0.5 in. (2146 mm)
 - T** Distance Between Shanks 3 ft. 5 in. (1041 mm)
 - Number of Teeth 3

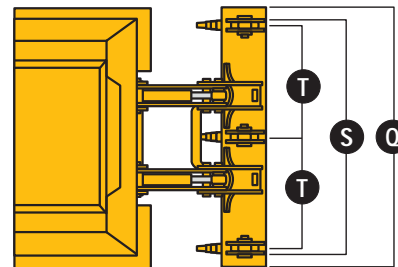
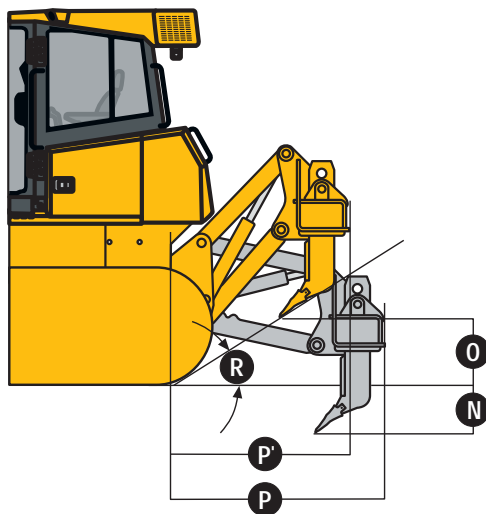

850J WH WASTE HANDLER

Key: ● Standard equipment ▲ Optional or special equipment

*See your John Deere dealer for further information.

Base	Landfill	
850J	Package	Engine
●	●	Certified to EPA Tier 3 regulations
●	●	Electronic control with automatic engine protection
●	●	Dual safety element dry-type air cleaner, evacuator valve
●	●	Muffler, self draining, under hood, with vertical stack
●	●	Environmental service drains
▲	▲	Ether start aid
▲	▲	Chrome exhaust
▲	●	Rotary ejector engine air precleaner
Cooling		
●	●	Cooling fan, suction type, programmable reversing
●	●	Engine coolant radiator (6 fins per in.)
●	●	Hydrostatic cooler (oil/air – 6 fins per in.)
●	●	Hydraulic cooler (oil/air – 6 fins per in.)
●	●	Enclosed safety fan guard (conforms to SAE J1308 and ISO3457)
●	●	Perforated engine side shields
●	●	Split-hinge bar-type grille
▲	●	Extreme-duty grille
Transmission		
●	●	Diagnostic test ports
●	●	Environmental service drains
▲	●	Final-drive seal guards
●	●	Onboard diagnostics
Hydraulic System		
●	●	Two-function hydraulics
▲	▲	Three-function hydraulics
▲	▲	Four-function hydraulics with rear plumbing
Electrical		
●	●	Sealed alternator, 80 amps
●	●	Master electrical disconnect switch
●	●	Lights, grille or lift cylinder mounted (2) and rear mounted (1)
▲	●	Work lights (4), cab roof mounted
Mainframe, Access Panels		
●	●	Tilt operator station transmission access
●	●	Front tow loop
●	●	Integral bottom protection
●	●	Bottom access covers (bolt-on, 6 total, 5 swing away)
●	●	Vandal protection: Engine access door / Side tank access doors / Fuel tank / Instrument panel / Transmission reservoir / Hydraulic reservoir

Base	Landfill	
850J	Package	Attachments
▲	▲	Retrieval hitch with pin
▲	▲	Extended rigid drawbar with pin for pull-type implements
▲	▲	Counterweight, rear, 720 lb. (327 kg)
▲	▲	Counterweight, rear, 1,000 lb. (454 kg)
▲	▲	Ripper, rear, three shank
▲	▲	Cab screens
Undercarriage		
●	●	Oscillating undercarriage with remote lube
●	●	Full-length, smooth-surface track frame covers
●	●	Guides, front and rear, with bolt-on wear strips
●	●	Segmented sprockets
●	●	Double-flange rollers
●	●	Maintenance-free center crossbar pivot
Operator's Station		
▲	●	Cab with roof-mounted air conditioner (24,000 BTU) and heater
●	●	Left and right quarter hinged windows
●	●	Tinted safety glass
●	●	Dome light
●	●	Fresh-air-intake heater/defroster
●	●	Windshield wiper/washers (3) for windshield and doors
●	●	Mechanical suspension high-back fabric seat
▲	▲	Air suspension high-back fabric seat
●	●	3-in. (76 mm) retractable seat belt
●	●	Backrest tilt, thigh support, lumbar, height, weight, and fore-aft positioning
●	●	Power port, 12 volt
▲	▲	Second power port
●	●	Lockable dash-mounted storage compartment
▲	▲	Rear wiper, two speed
▲	▲	AM/FM weather-band radio and digital clock
▲	▲	External mounted attachment mirror
▲	▲	JDLink™ wireless communication system
Landfill Configuration		
▲	●	Tank guards
▲	▲	Lift-cylinder hose guards
●	●	Blade trash rack
▲	●	Beacon
▲	▲	30-in. (762 mm) extreme-service shoes with trapezoidal holes
▲	▲	36-in. (914 mm) extreme-service shoes with trapezoidal holes

CONTROL OWNING AND OPERATING COSTS

Customer Personal Service (CPS) is part of John Deere's proactive, fix-before-fail strategy on machine maintenance that will help control costs, increase profits, and reduce stress. Included in this comprehensive lineup of ongoing programs and services are:

Fluid analysis program – tells you what's going on inside *all* of your machine's major components so you'll know if there's a problem *before* you see a decline in performance. Fluid analysis is included in most extended coverage and preventive-maintenance agreements.

Component life-cycle data – gives you vital information on the projected life span of components and lets you make informed decisions on machine maintenance by telling you approximately how many hours of use you can expect from an engine, transmission, or hydraulic pump. This information can be used to preempt catastrophic downtime by servicing major components at about 80 percent of their life cycle.

Preventive Maintenance (PM) agreements – give you a fixed cost for maintaining a machine for a given period of time. They also help you avoid downtime by ensuring that critical maintenance work gets done right and on schedule. On-site preventive maintenance service performed where and when you need it helps protect you from the expense of catastrophic failures and lets you avoid waste-disposal hassles.

Extended coverage – gives you a fixed cost for machine repairs for a given period of time so you can effectively manage costs. Whether you work in a severe-service setting or just want to spread the risk of doing business, this is a great way to custom-fit coverage for your operation. And an extended coverage contract also travels well because it's backed by John Deere and is honored by *all* Deere construction dealers.

Customer Support Advisors (CSAs) – Deere believes the CSA program lends a *personal* quality to Customer Personal Service (CPS). Certified CSAs have the knowledge and skills for helping make important decisions on machine maintenance and repair. Their mission is to help you implement a plan that's right for *your* business and take the burden of machine maintenance off your shoulders.



JOHN DEERE

DKA850JWH Litho in U.S.A. (08-05)

Net engine power is with standard equipment including air cleaner, exhaust system, alternator, and cooling fan at test conditions per ISO9249. No derating is required up to 10,000-ft. (3050 m) altitude.

Specifications and design subject to change without notice. Wherever applicable, specifications are in accordance with SAE standards. Except where otherwise noted, these specifications are based on a unit with cab, waste-handling package, full fuel tank, 175-lb. (79 kg) operator, and standard equipment: 140-in. (3556 mm) outside-mount semi-U blade or 158-in. (4013 mm) PAT blade.

