

301.7D

Mini Hydraulic Excavator



Engine

Gross Power (ISO 14396)	17.9 kW	24.3 hp
-------------------------	---------	---------

Weights

Transport Weight with Canopy	1610 kg	3,550 lb
Transport Weight with Cab	1720 kg	3,792 lb
Transport Weight with Canopy and Extending Undercarriage	1735 kg	3,825 lb
Transport Weight with Cab and Extending Undercarriage	1845 kg	4,068 lb

**High
performance
in a compact
design for
greater
versatility and
controllability.**



Contents

Performance4
Versatility.....6
Productive Comfort.....7
Engine and Serviceability.....8
Specifications.....10
Standard Equipment.....12
Optional Equipment.....13



The Cat® 301.7D gives you a blend of power, control and stability to make your working day easier and more productive.

Performance

Powerful digging combined with smooth control.



Dig Force

The new 301.7D boasts high bucket and stick forces making it an impressive and productive excavator.

The choice of two stick lengths allows the customer to configure his machine to deliver even higher stick forces or reach.

Stability

An extending undercarriage and fold out dozer blade allow the machine to be configured for optimum performance. Blade extensions are retained with the dozer making them easy to use and ensuring that they are not lost.



Dozer Float

Ground levelling and finishing applications are fast and easy with the dozer float function engaged making site clean-up much more efficient.

Long Dozer Option

The optional longer dozer blade enables improved 'dig to blade' characteristics to give easier on site clean up.



100% Pilot Controls

Delivers excellent machine control and lifetime 'as new' performance eliminating the need for linkage and cable maintenance, lowering owning and operating costs and resulting in less downtime.



Versatility

Flexibility built in for a variety of jobs.



High Flexibility

Compact in size and with a transport weight under 2000 kg (4,500 lb), the 301.7D can be transported easily using a conventional trailer and pick up truck or transit van.

The sturdy hoisting eyelets on the cab roof enable the easy and rapid relocation of the machine between sites.

Automatic Swing Lock

Safe transportation of the machine is aided by the Cat automatic swing lock which locks the machines upper body in place when the control console is raised or the engine is stopped.

Work Tools

A range of work tools are available including buckets, hammer and auger to take advantage of the machines versatility. All these tools are matched to the machine to optimize performance and deliver excellent value through productivity and long life.

Auxiliary Hydraulics as Standard Fit

Machine is 'ready to work'. Hammer and two way lines complete with quick disconnect fittings as standard. Connections are located close to the tool to reduce hose lengths and any potential damage. Additional line options are available to further increase machine versatility. Stick and bucket cylinder hoses are protected by routing them through the boom.

Auxiliary Flow Control

Machines configured with proportional auxiliary hydraulics, include the ability to adjust the flow for even greater tool control. Especially useful with tools such as angling ditching buckets.



Productive Comfort

Large operator environment and ergonomic control layout.

Cab Comfort

The Cat 301.7D gives the operator a large comfortable space in which to work. The ergonomic control layout, travel pedals and adjustable wrist rests are engineered to minimize operator fatigue and increase productivity.

The layout is designed for easy cleaning, minimizing downtime between jobs.

There is a choice of cab with heater or canopy available. The canopy offering two sided access for even greater on site versatility.



Split Front Window

The lower front window section slides into the upper section frame.

Both sections are then raised and stored in the roof using a gas assisted mechanism.

This allows the operator to position in front window to suit their visibility and ventilation requirements with easy storage.

Engine and Serviceability

Superior power with easy access and minimal maintenance requirements keep you working.



Customer Support – Unmatched Support Makes the Difference

Your Cat dealer is ready to assist you with your purchase decision and everything after.

- Financing packages are flexible to meet your needs
- Unmatched parts availability keeps you working
- Make comparisons of machines, with estimates of component life, preventative maintenance and cost of production
- For more information on Cat products, dealer services and industry solutions, visit www.cat.com

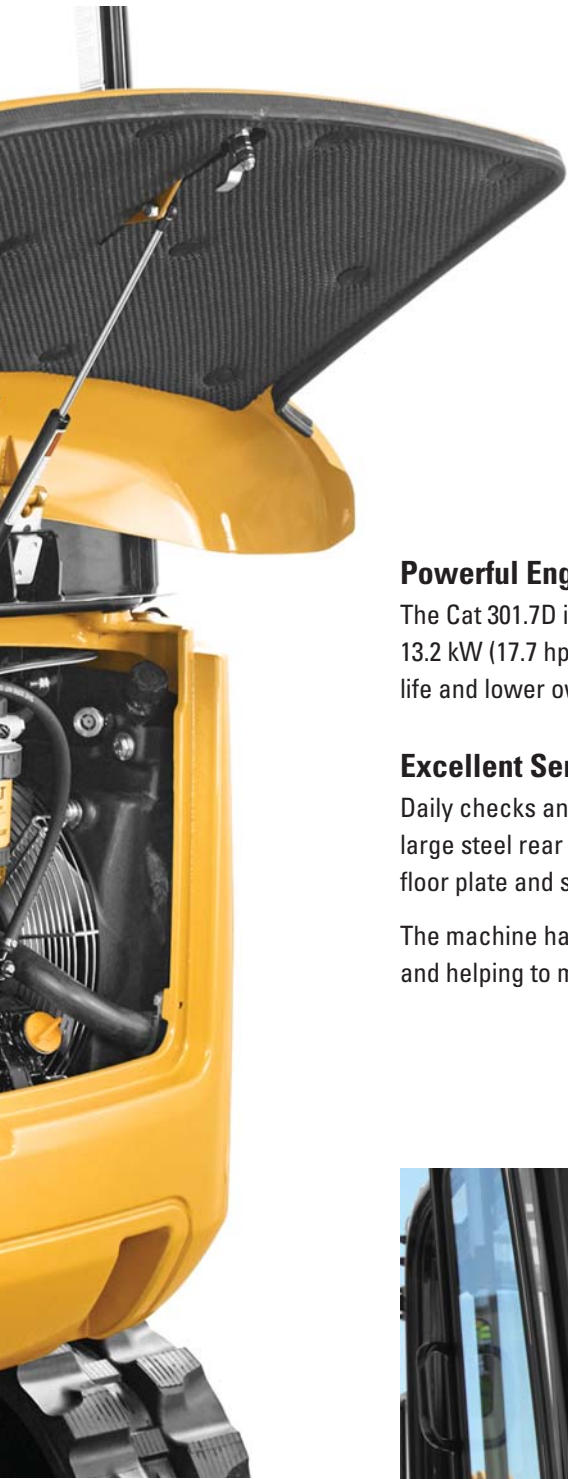

Powerful Engine

The Cat 301.7D is fitted with a 17.9 kW (24.3 hp) gross power engine that is installed at a much lower rated 13.2 kW (17.7 hp). This is designed to reduce engine wear, give cooler running temperatures, with longer life and lower owner and operating costs.

Excellent Service Access

Daily checks and regular service points including fuel and hydraulic oil fill are easily reached via the large steel rear door. The main hydraulic valve and lines are also easily reached through a removable floor plate and side panels.

The machine has durable steel body panels all around, offering good resistance to impact damage and helping to maintain the machine's appearance and value.



301.7D Mini Hydraulic Excavator Specifications

Engine

Engine Model	Yanmar 3TNV76	
Rated Net Power @ 2,200 rpm (ISO 9249)	13.2 kW	17.7 hp
Gross Power (ISO 14396)	17.9 kW	24.3 hp
Displacement	1116 cm ³	40 in ³

Weights

Transport Weight with Canopy	1610 kg	3,550 lb
Transport Weight with Cab	1720 kg	3,792 lb
Transport Weight with Canopy and Extending Undercarriage	1735 kg	3,825 lb
Transport Weight with Cab and Extending Undercarriage	1845 kg	4,068 lb

Travel System

Travel Speed	2.8 km/h/ 5.6 km/h	1.74 mph/ 3.48 mph
Gradeability	30°/58%	

Service Refill Capacities

Fuel Tank Capacity	24 L	6.3 gal
Hydraulic Tank Capacity	21 L	5.5 gal

Blade

Width	990 mm	39 in
Height	230 mm	9 in
Dig Depth – Standard Blade	317 mm	12.5 in
Lift Height – Standard Blade	197 mm	8 in

Hydraulic System

Pump Flow @ 2,200 rpm	23.8 + 23.8 + 19.0 + 6.4 L/min	6.29 + 6.29 + 5.0 + 1.7 gal/min
Operating Pressure – Equipment	200 bar	2,900 psi
Operating Pressure – Travel	200 bar	2,900 psi
Operating Pressure – Swing	125 bar	1,813 psi
Auxiliary Circuits		
Primary	30 L/min at 170 bar	8 gal/min at 2,465 psi
Secondary	17 L/min at 200 bar	4.5 gal/min at 2,900 psi
Maximum Bucket Force	18.8 kN	4,226 lbf
Maximum Stick Force – Standard Stick	11.2 kN	2,518 lbf
Maximum Stick Force – Long Stick	9.8 kN	2,203 lbf

Lift Capacity at Ground Level

Lift Point Radius	2 m (6'7")				2.5 m (8'2")				3 m (9'10")				Maximum			
	Front		Side		Front		Side		Front		Side		Front		Side	
	kg	lb	kg	lb	kg	lb	kg	lb	kg	lb	kg	lb	kg	lb	kg	lb
Long Stick/ Fixed Undercarriage	835*	1,840*	580	1,279	605*	1,334*	400	882	470*	1,036*	325	717	440*	970*	300	661

*The above loads are in compliance with hydraulic excavator lift capacity rating standard ISO 10567:2007 and they do not exceed 87% of hydraulic lifting capacity or 75% of tipping capacity. The excavator bucket weight is not included on this chart.

Dimensions

All dimensions are approximate.

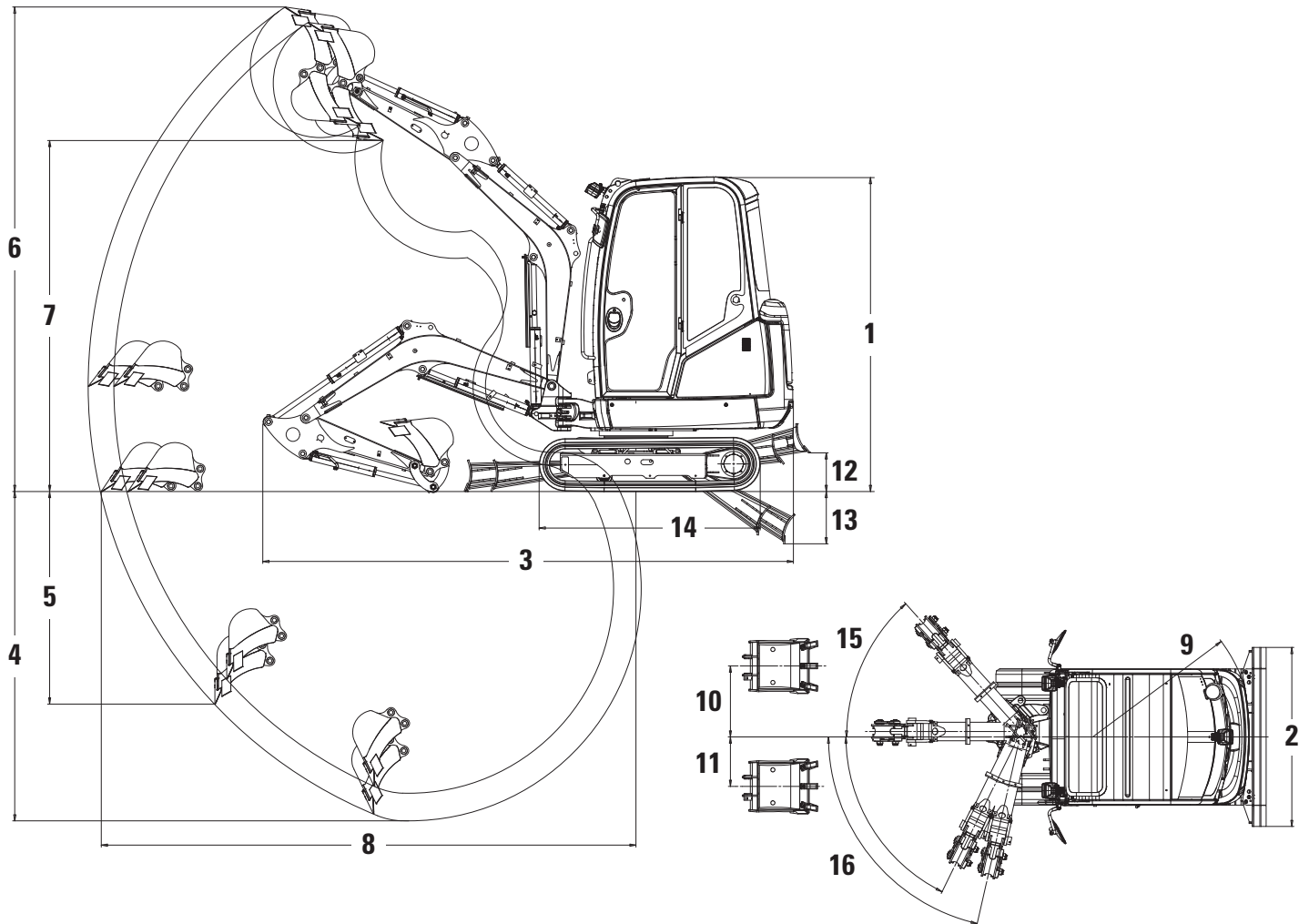

	Standard Stick		Long Stick	
1 Height	2290 mm	7'5"	2290 mm	7'5"
2 Width	990 mm-1300 mm	3'3"-4'3"	990 mm-1300 mm	3'3"-4'3"
3 Transport Length (arm lowered)	3855 mm	12'8"	3855 mm	12'8"
4 Maximum Digging Depth	2200 mm	7'3"	2400 mm	7'11"
5 Maximum Vertical Dig Depth	1430 mm	4'8"	1620 mm	5'4"
6 Maximum Dig Height	3485 mm	11'5"	3595 mm	11'9"
7 Maximum Dump Height	2500 mm	8'3"	2610 mm	8'7"
8 Maximum Reach at Ground Level	3700 mm	12'2"	3895 mm	12'9"
9 Tail Swing Radius	1170 mm	3'10"	1170 mm	3'10"
10 Maximum Boom Offset (RH)	520 mm	1'8"	520 mm	1'8"
11 Maximum Boom Offset (LH)	360 mm	1'2"	360 mm	1'2"
12 Maximum Dozer Lift Height	200 mm	8"	200 mm	8"
13 Maximum Dozer Dig Depth	320 mm	1'0"	320 mm	1'0"
14 Length of Undercarriage (Fixed)	1445 mm	4'9"	1445 mm	4'9"
14 Length of Undercarriage (Extending)	1600 mm	5'3"	1600 mm	5'3"
15 Boom Swing Angle (RH)	48°		48°	
16 Boom Swing Angle (LH)	77°/64°		77°/64°	

301.7D Standard Equipment

Standard Equipment

Standard equipment may vary. Consult your Cat dealer for details.

- 230 mm (9 in) rubber track
- Hammer/two way auxiliary hydraulic lines
- Auxiliary quick disconnect couplers
- Standard length dozer blade
- Working light mounted to boom
- Canopy – ROPS and TOPS protection
- Retractable seat belt
- Suspension seat, vinyl covered
- Travel pedals
- Maintenance free battery
- Hydraulic oil cooler
- Fixed undercarriage
- Automatic swing park brake
- Dozer float

Optional Equipment

Optional equipment may vary. Consult your Cat dealer for details.

- Cab, radio ready – ROPS and TOPS protection
- Suspension seat, fabric covered
- Boom stick or dozer blade check valve
- Mirror pack
- Removable swing stop
- Additional hydraulic circuit diverted from bucket cylinder
- Cab top guard to ISO 10262 (Level 1)
- Auto engine idle
- Joystick mounted proportional auxiliary control with flow control
- Long dozer blade
- Long stick
- Extending undercarriage
- Cab/canopy lights
- Second auxiliary lines

301.7D Mini Hydraulic Excavator

For more complete information on Cat products, dealer services, and industry solutions, visit us on the web at www.cat.com

© 2012 Caterpillar Inc.
All rights reserved

Materials and specifications are subject to change without notice. Featured machines in photos may include additional equipment. See your Cat dealer for available options.

CAT, CATERPILLAR, SAFETY.CAT.COM, their respective logos, "Caterpillar Yellow" and the "Power Edge" trade dress, as well as corporate and product identity used herein, are trademarks of Caterpillar and may not be used without permission.

AEHQ6853 (09-2012)

