

D6R

Track-Type Tractors



Engine – STD

Engine Model	Cat® C9 ACERT™	
Net Power – ISO 9249	130 kW	175 hp

Engine – XL/LGP

Engine Model	Cat® C9 ACERT™	
Net Power – ISO 9249	145 kW	195 hp

Weights – STD S

Operating Weight	18 225 kg	40,179 lb
Shipping Weight	15 017 kg	33,106 lb

Features

Cab and Controls

Comfort features, excellent visibility and low-effort controls help improve operator efficiency so they can stay focused and more productive on the job.

Engine and Power Train

The Cat® C9 engine with ACERT™ Technology provides optimal engine performance and reliability, is capable of meeting EPA Tier 2 and EU Stage II emission levels and has been certified to China Stage II (GB 20891-2007) emission standards.

Undercarriage

The Cat elevated sprocket design offers outstanding traction and balance. A variety of undercarriage configurations and components allow the machine to be matched to application needs.

Integrated Electronic Solutions

Grade control systems help improve operator efficiency and accuracy to help get more work done – on time and on budget. Flexibility is improved as well, allowing easy adjustments to specification changes on the jobsite. The Cat AccuGrade system and controls can be integrated from the factory for even greater system reliability.

Serviceability and Support

The D6R is designed with ease of serviceability in mind to help reduce your operating costs and keep the machine at work on the jobsite. And the D6R comes standard with the renowned service of the Cat dealer network. From preventive maintenance to outstanding parts and service support, Cat dealers excel at keeping you up and running.

Contents

Cab and Controls.....	3
Engine	4
Power Train.....	5
Structures.....	6
Undercarriage	7
Work Tools.....	8
Integrated Electronic Solutions.....	9
Serviceability	10
Total Customer Support	11
D6R Track-Type Tractor Specifications.....	12
D6R Standard Equipment.....	16
D6R Optional Equipment	17
Notes.....	18



Caterpillar has been the world leader in Track-Type Tractors for more than a century. The D6R combines legendary Cat durability and reliability with proven technology designed to reduce emissions while improving your productivity and your bottom line. From rugged structures to fully integrated engine and power train systems, the D6R is a world-class tractor built to help you produce the highest quality work in a variety of applications.

Cab and Controls

Productivity, safety, comfort

Operator Environment

The D6R features an isolation-mounted, pressurized cab that reduces noise and vibration. Large, single pane windows offer good views all around the machine for maximum productivity and enhanced job site safety. The Comfort Series seat is offset by 15 degrees for better visibility. It features fully adjustable positioning and armrests to provide a comfortable platform when working on steep grades or slopes.

Gauges and warning lights on the in-dash instrument cluster are easy to read, even in direct sunlight. The Cat Monitoring System Display gives operators and service technicians easy access to operating and maintenance information. The system provides three levels of warning and system monitoring so the operator can stay informed and still concentrate on the job.

Heating and Air Conditioning vents evenly distribute airflow within the cab. The cab is pre-wired for a 12-volt or 24-volt radio, equipped with two speakers, an antenna and a radio mount recessed in the headliner.

Dozer and Ripper Controls

All D6R controls are ergonomically designed for low-effort and ease of operation. The dozer and ripper control levers feature pilot-operated hydraulics for added operator comfort and precise control. When the AccuGrade system is activated, the dozer is electro-hydraulically controlled. When the operator returns to manual control, the dozer is operated through the pilot hydraulic system.

Throttle Rocker Switch

With the touch of a finger, the rocker switch activates high or low idle. A decelerator pedal gives the operator full control of engine speed when the rocker switch is in the high idle position. Engine speed can also be easily set in any range between high and low idle by simultaneously using the decelerator pedal to set the desired speed and pressing the throttle switch in for three seconds.

Steering and Transmission Control

The operator uses a single handle control to perform all direction and gear selection. The tiller bar control allows the operator to work more precisely in close areas around structures, grade stakes and other machines. Differential Steering provides the finest modulation in the industry.

Work Tool Lock-Out Switch

The work tool lock-out valve prevents inadvertent operation of the hydraulic work tool attachments for added safety.



Engine

Power and reliability



Caterpillar is one of the world's leading engine manufacturers. Every component of a Cat® engine is carefully designed to maximize durability and reliability. Precise controls optimize power and fuel efficiency while reducing emissions. Modular design and advanced electronic diagnostics enhance the engine's serviceability.

ACERT Technology

The D6R features a Cat C9 engine with ACERT™ Technology. A series of Caterpillar innovations provide advanced electronic control, precision fuel delivery and refined air management, resulting in outstanding performance and lower emissions. To help customers work within expanding global regulatory requirements, the C9 engine with ACERT Technology has been certified to China Stage 2 (GB 20891-2007) emissions compliance.

ATAAC

The air-to-air aftercooler (ATAAC) – part of the advanced air management system – brings cool air to the engine. This increases life, reduces emissions, and helps maximize fuel efficiency.

Fuel Delivery

Multiple injection fuel delivery very precisely controls the combustion cycle. This lowers combustion chamber temperatures to reduce emissions and translates into more work output per unit of fuel. The Hydraulic Electronic Unit Injector (HEUI™) fuel system controls injection pressure over the entire engine operating speed range for complete control over injection timing, duration, and pressure.

Fractured Split Connecting Rods

Design creates near-perfect joint alignment, maximizing rod bearing life. This, in combination with a high efficiency oil filter, ensures long engine life.

Cat Advanced High Efficiency Oil Filter

Advanced oil filters provide outstanding contamination control for a much cleaner running engine. The advanced filtration is accomplished without the shorter change intervals often required with other brands.

Next Generation Modular Radiator (NGMR)

Outstanding cooling is achieved through a six-core parallel Flow system. A modular design enhanced reliability, and a single core can be taken out without removing the entire radiator. Site gauge allows for quick service checks.

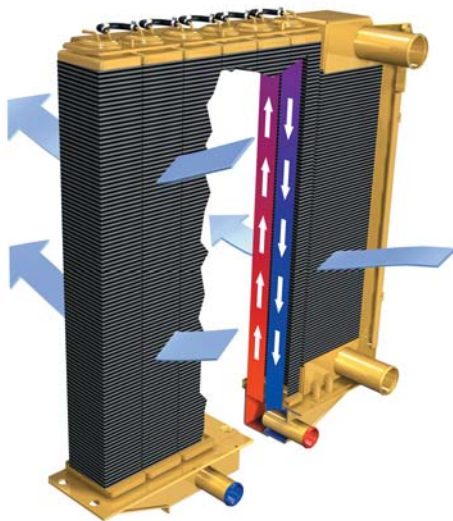



Power Train

Powerful efficiency

The power shift transmission, unique Cat torque divider and differential steering are matched with the C9 engine to deliver outstanding power and reliability. The integrated system efficiently puts more power to the ground, utilizing more of the available horsepower, so you get more done with less.

Differential Steering System

Differential steering puts you on the leading edge of productivity by maintaining power to both tracks while turning. When one track speeds up, the other slows down an equal amount. Maneuverability – especially with large blade loads – is improved, as well as cycle times in some applications. Greater load capacity, power and speed control are possible in soft underfoot conditions on steep slopes because both tracks are powered during turns. A single tiller bar controls all directional and speed functions for ease of operation.

Torque Divider

A unique Cat torque divider sends 70 percent of engine torque through a converter and 30 percent through a direct drive shaft for greater driveline efficiency and higher torque multiplication. The D6R torque divider provides high reliability and low dynamic torque. Components are designed to absorb full engine power, and deliver an optimum combination of operator efficiency and driveline reliability.

Planetary Power Shift Transmission

The transmission includes three speeds forward and three speeds reverse, featuring thick, large diameter, high capacity, oil-cooled clutches. These clutches provide higher torque capacity and increase service life. The planetary power shift transmission has a proven, robust mechanical control system. Modular transmission and differential slide into rear case for servicing ease, even when a ripper is installed. An oil-to-water cooler provides maximum cooling capacity, and forced oil flow lubricates and cools clutch packs for maximum clutch life.

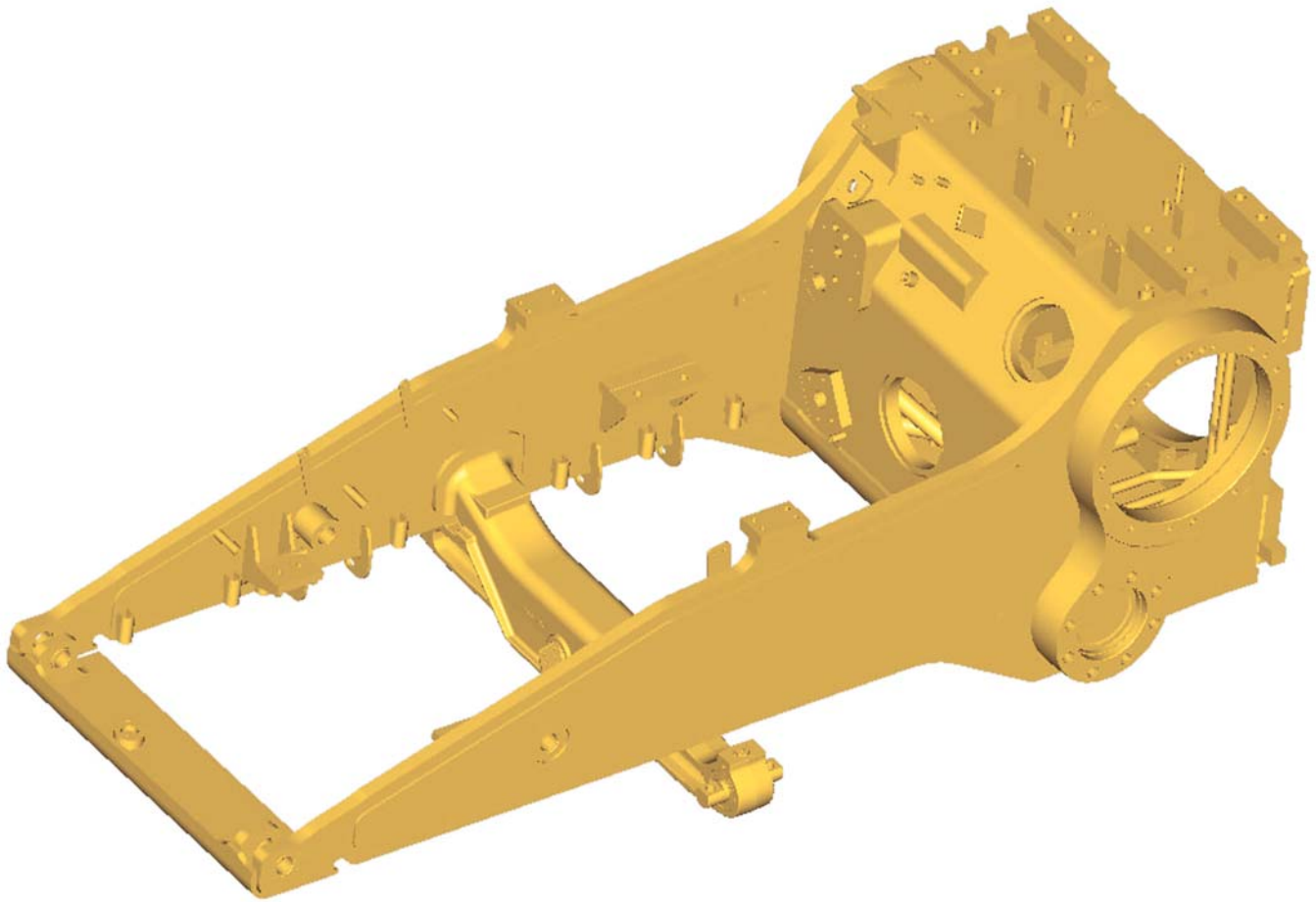

Structures

Rugged design for maximum service

The foundation of every Cat dozer is a rugged frame built to absorb high impact shock loads and twisting forces. A reinforced saddle, welded front cross-member and steel castings on the main case add to the overall strength.

The pivot shaft is bolted to the mainframe and connects to the rear roller frames to allow independent oscillation. The pivot shaft distributes impact loads through the case. This design eliminates alignment problems and the need for diagonal braces on the roller frames.

The pinned equalizer bar gives the roller frames the ability to oscillate up and down to better match ground contours for maximum traction and operator comfort. Bolted end pins offer longer life and reduce downtime with improved serviceability and reliability. A remote lubrication point in the engine compartment provides easy access to lubricate the center pin of the equalizer bar as part of scheduled maintenance practices.

Undercarriage

Proven productivity

Since its ground-breaking introduction in 1978, more than 100,000 Cat Track-Type Tractors have been sold with the elevated sprocket “high drive” undercarriage. This is a field-proven design that offers outstanding machine performance and longer component life.

Ground and implement shock loads are transferred to the mainframe to protect final drives, axles and steering components from harsh impacts for longer component life.

The elevated sprocket design gives the operator excellent sight lines to the blade, sides and back of the machine. However, machine center of gravity remains low, offering excellent stability, balance and traction.

Modular power train components make it quick to remove and repair the transmission, final drives, steering differential or brakes.

Modular undercarriage components simplify service. Lifetime lubricated idlers and track/carrier rollers provide the ability to re-use internal components and rebuild or reshell components. This reduces owning and operating costs, and saves raw materials and natural resources.

Heavy Duty Undercarriage

Standard Heavy Duty undercarriage components are designed for extended wear life in abrasive conditions and high impact applications like forestry, side-slopes, or working in rocky or uneven terrain. Heavy duty track is designed for enhanced penetration. The leading and trailing edges of each track shoe overlap the adjacent shoe to increase durability and component life.

SystemOne™ Undercarriage

Optional SystemOne undercarriage for XL and LGP machines can help reduce total undercarriage owning and operating costs in many applications. SystemOne features lifetime sealed and lubricated cartridges to eliminate bushing turns, and sprockets require no replacement during the life of the chain. All SystemOne undercarriage components are designed to work and wear as a system for longer track life.

Track Shoes

Moderate Service and Extreme Service track shoes are available for both Heavy Duty and SystemOne Undercarriage to help optimize the machine based on its most frequent applications. Proper track shoe selection helps minimize wear for optimal undercarriage life – especially in high impact or highly abrasive conditions.



Work Tools

Equipped for the job



L-Shaped Push Arms

L-shaped push arms bring the blade closer to the machine, providing excellent maneuverability, balance and blade penetration. The design provides solid lateral stability and better cylinder positions for constant pry-out independent of blade height.

Load Sensing Hydraulics

Field-proven, load-sensing, pilot controlled hydraulics respond to operating requirements by automatically and continually adjusting hydraulic power to maximize work tool efficiency.

Cat Blades

Semi-Universal, Straight and Angle blade designs feature a strong box-section design, made from Cat DH-2™ steel with high tensile strength to stand up to the most severe applications. Heavy moldboard construction and hardened bolt-on cutting edges and end bits add strength and durability.

- Semi-Universal Blade – designed for superior load retention and penetration in tightly packed materials.
- Straight Blade – versatile blade, ideal for heavier materials.
- Angle Blade – secured by outside-mounted push arms using a pinned connection that allows blade angling and tilting, left or right. Blade angle is changed manually and blade tilt is changed hydraulically.

Multi-Shank Ripper

The three-shank parallelogram style ripper is available with curved or straight ripper shanks. This ripper is an excellent tool for preparing hard-packed material before dozing operations.

Rear Counterweight

Optimize balance for backing up steep slopes or increasing performance in heavy dozing applications. Proper machine balance also helps the undercarriage wear more evenly. Rear counterweights are recommended if another rear attachment is not specified.

Winch

See your Cat dealer for available Winch options best suited to your applications.



Integrated Electronic Solutions

Technology to reduce costs and improve productivity

AccuGrade System for Track-Type Tractors

The AccuGrade system automates blade control for improved grading accuracy and more cost effective operation. Machine-mounted sensors calculate precise blade slope and elevation, then automatically adjust the blade to maintain grade. Automated blade control improves efficiency by reaching grade faster and in fewer passes, reducing the need for traditional survey stakes or grade checkers.

AccuGrade™ Ready Option

AccuGrade systems and controls can be integrated from the factory, making system installation and setup quick and easy. Integration also provides greater system protection and reliability.

AccuGrade Laser

Laser signals from a transmitter on the work site are picked up by a machine mounted receiver to provide a constant grade reference. The system calculates blade adjustments to achieve grade, makes automatic elevation adjustments and provides automatic blade control. The operator simply steers the machine. The system also calculates cut/fill requirements for manual blade control.

AccuGrade GPS

Computes machine positioning information, compares the position of the blade relative to a more complex design plan, and delivers that information to the operator via an in-cab display.

Product Link

The optional Product Link* system is a factory installed or easily retrofitted wireless system that simplifies equipment fleet tracking. Using satellite or cellular technology, it automatically reports key machine parameters such as location, machine hours, active and logged service codes and security alarms.

* Product Link licensing not available in all areas.

Serviceability

Stay up and running



Cat machines are designed with serviceability in mind. Modular components, easy access to regular service points and features that enable quicker diagnostics all add up to less maintenance time and more time on the job.

Cat Monitoring System

The D6R features a flexible monitoring system that is easily upgraded by flashing software. As technology changes and new electronics and software become available, this upgradable monitoring system allows the machine to be easily updated and take advantage of improvements. With the use of a Cat Electronic Technician (ET), your Cat dealer can determine historical performance parameters of the machine.

The Cat Monitoring System is designed to:

- Allow easy upgrades
- Reduce downtime
- Match software to unique application needs
- Provide feedback on machine performance events

Scheduled Oil Sampling (S•O•SSM) Analysis

Monitor machine health and identify key maintenance needs before they lead to downtime through Cat Scheduled Oil Sampling. Cat machines feature live sampling ports for the engine oil, power train hydraulics and coolant. Cat oil sampling offers accurate analysis using tests designed by Caterpillar for Cat products, as well as knowledgeable interpretation of the results.

Built to be Rebuilt

Major components on the D6R are built to be rebuilt, extending the useful life of the machine. Machine and component rebuilds save money, and offer a sustainability element by saving raw materials and natural resources. See your Cat dealer to learn more about rebuild options.



Total Customer Support

Renowned dealer support

Only Cat machines come with the industry's best sales and service support – the Cat Dealer network. From helping you choose the right machine to ongoing support, your Cat dealer provides the best in sales and service. Manage your costs with preventive maintenance programs like Custom Track Service, Scheduled Oil Sampling (S•O•SSM) analysis, and guaranteed maintenance contracts. Stay productive with best-in-class parts availability. Your Cat dealer can even help with operator training to help you boost your profits.

And when it's time for replacement, your Cat dealer can help you save even more with Genuine Cat Remanufactured parts. Remanufactured power train and hydraulic components cost less, but come with the same warranty and reliability as new products. Talk with your Cat dealer to learn more about reducing waste and saving money through Cat Remanufacturing.

D6R Track-Type Tractor Specifications

Engine – STD

Engine Model	Cat® C9 ACERT™	
Gross Power – SAE J1995	148 kW	199 hp
Gross Power – ISO 14396	144 kW	193 hp
Net Power – SAE J1349	130 kW	175 hp
Net Power – ISO 9249	130 kW	175 hp
Net Power – 80/1269/EEC	130 kW	175 hp
Bore	112 mm	4.4 in
Stroke	149 mm	5.9 in
Displacement	8.8 L	537 in ³

Engine – XL/LGP

Engine Model	Cat® C9 ACERT™	
Gross Power – SAE J1995	163 kW	219 hp
Gross Power – ISO 14396	159 kW	213 hp
Net Power – SAE J1349	145 kW	195 hp
Net Power – ISO 9249	145 kW	195 hp
Net Power – 80/1269/EEC	145 kW	195 hp
Bore	112 mm	4.4 in
Stroke	149 mm	5.9 in
Displacement	8.8 L	537 in ³

- Engine ratings apply at 2,000 rpm
- Net power advertised is the power available at the engine flywheel when the engine is equipped with a fan at maximum speed, air cleaner, muffler and alternator
- No deratings required up to 2286 m (7,500 ft) altitude, beyond 2286 m (7,500 ft) automatic derating occurs

Transmission

1.0 Forward	3.8 km/h	2.3 mph
2.0 Forward	6.6 km/h	4.1 mph
3.0 Forward	11.5 km/h	7.1 mph
1.0 Reverse	4.8 km/h	3 mph
2.0 Reverse	8.4 km/h	5.2 mph
3.0 Reverse	14.6 km/h	9.1 mph

Service Refill Capacities

Fuel Tank	424 L	112 gal
Cooling System	76.8 L	20.3 gal
Engine Crankcase	28 L	7.4 gal
Power Train	145.7 L	38.5 gal
Final Drives (each)	13.6 L	3.6 gal
Roller Frames (each)	24.6 L	6.5 gal
Pivot Shaft Compartment	5 L	1.3 gal
Hydraulic Tank	51.5 L	13.6 gal

Weights

Operating Weight – STD S	18 225 kg	40,179 lb
Shipping Weight – STD S	15 017 kg	33,106 lb
Operating Weight – STD A	18 669 kg	41,148 lb
Operating Weight – STD SU	18 325 kg	40,400 lb
Operating Weight – XL SU	20 080 kg	44,270 lb
Operating Weight – LGP S	21 715 kg	47,874 lb
Shipping Weight – STD A	15 017 kg	33,106 lb
Shipping Weight – STD SU	15 017 kg	33,106 lb
Shipping Weight – XL SU	17 012 kg	37,505 lb
Shipping Weight – LGP S	19 153 kg	42,225 lb

- Operating weight includes lubricants, coolant, full fuel tank, standard track, cab, hydraulic controls, drawbar and operator.
- Shipping weight includes lubricants, coolant, cab, hydraulic controls, standard track and 10 percent fuel.

Undercarriage

Width of Shoe – STD/XL	560 mm	22 in
Width of Shoe – LGP	915 mm	36.02 in
Shoes/Side – STD	39	
Shoes/Side – XL	41	
Shoes/Side – LGP	45	
Grouser Height	65 mm	2.56 in
Pitch	203 mm	7.99 in
Ground Clearance	383 mm	15 in
Track Gauge – STD/XL	1880 mm	74 in
Track Gauge – LGP	2286 mm	90 in
Track on Ground – STD	2664 mm	104.88 in
Track on Ground – XL	2871 mm	113.03 in
Track on Ground – LGP	3275 mm	128.94 in
Ground Contact Area (STD Track) – STD	2.98 m ²	4,620 in ²
Ground Contact Area (STD Track) – XL	3.22 m ²	4,972 in ²
Ground Contact Area (STD Track) – LGP	5.99 m ²	9,288 in ²
Ground Pressure – STD	0.614 kg/cm ²	8.74 psi
Ground Pressure – XL	0.623 kg/cm ²	8.9 psi
Ground Pressure – LGP	0.362 kg/cm ²	5.15 psi

- STD, XL with SU blade, with no rear attachments unless otherwise specified.

Hydraulic Controls – Pump

Pump Capacity at	6900 kPa	1,001 psi
RPM at Rated Engine Speed	2,125 rpm	
Pump Output	214 L/min	56.5 gal/min
Lift Cylinder Flow	190 L/min	50.2 gal/min
Tilt Cylinder Flow	80 L/min	21.1 gal/min
Ripper Cylinder Flow	160 L/min	42.3 gal/min

Hydraulic Controls – Main Relief Valve

Pressure Setting	42 000 kPa	6,092 psi
------------------	------------	-----------

Hydraulic Controls – Maximum Operating Pressure

Bulldozer	19 300 kPa	2,799 psi
Bulldozer Tilt	19 300 kPa	2,799 psi
Tilt Cylinder	19 300 kPa	2,799 psi
Ripper (Lift)	19 300 kPa	2,799 psi
Ripper (Pitch)	19 300 kPa	2,799 psi
Steering	40 000 kPa	5,802 psi

Blades

SU-Blade Capacity	5.61 m ³	7.34 yd ³
SU-Blade Width	3260 mm	10 ft 8 in
S-Blade Capacity	3.89 m ³	5.09 yd ³
S-Blade Width	3360 mm	11 ft 0 in
A-Blade Capacity	3.93 m ³	5.14 yd ³
A-Blade Width	4166 mm	13 ft 8 in
LGP S-Blade Capacity	3.75 m ³	4.9 yd ³
LGP S-Blade Width	4063 mm	13 ft 4 in

Ripper

Type	Fixed Parallelogram	
Number of Pockets	3	
Overall Beam Width	2202 mm	87 in
Beam Cross Section	216 × 254 mm	8.5 × 10 in
Maximum Clearance Raised (under tip, pinned in bottom hole)	511 mm	20.1 in
Maximum Penetration	500 mm	19.7 in
Maximum Penetration Force	6603 kg	14,557 lb
Pryout Force	9134 kg	20,137 lb
Weight – with Three Shanks	1782 kg	3,932 lb

Standards

ROPS/FOPS	ROPS meets criteria SAE J395, SAE 1040 MAY94, ISO 3471-1994/ FOPS meets ISO 3449-1992 Level II
Brakes	Brakes meet criterion SAE J/ISO 10265 MAY98
Cab	Meets appropriate standards as listed below.

- The operator sound exposure Leq (equivalent sound pressure) measured according to the dynamic conditions in ISO 6396 is 79 dB(A) for a cab offered by Caterpillar when properly installed and maintained and with doors and windows closed when tested.
- Hearing protection may be needed when operating with an open operator station and cab (when not properly maintained or doors/windows open) for extended periods or in noisy environment.
- The exterior sound pressure level for a standard machine was measured according to the dynamic conditions in ISO 6395. On a machine equipped with a carrier roller, the sound level is 115 dB(A). On a machine without a carrier roller, the level is 114 dB(A).

D6R Track-Type Tractor

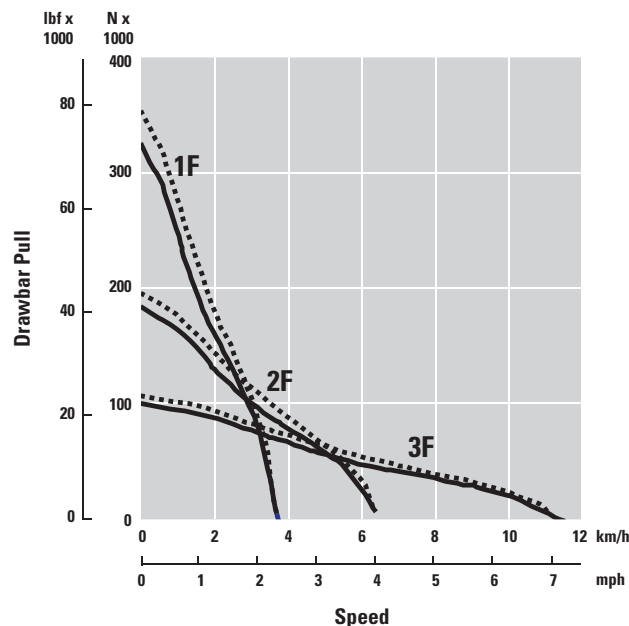

— STD
 XL/LGP

D6R Track-Type Tractor Specifications

Dimensions

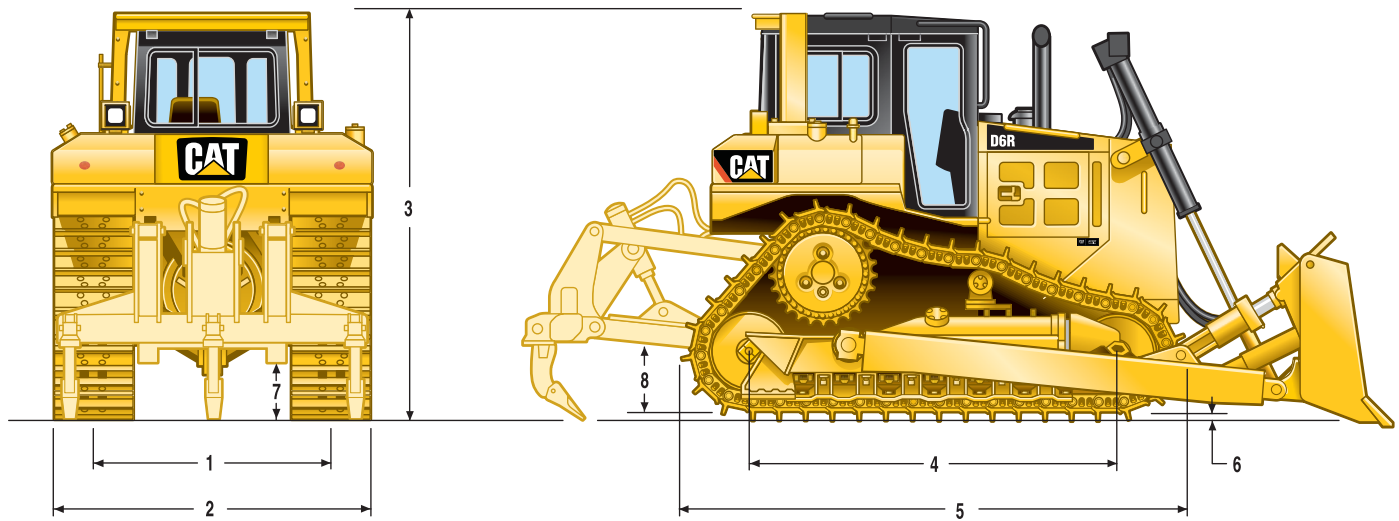

	STD	XL	LGP
1 Track gauge	1880 mm (74 in)	1880 mm (74 in)	2286 mm (90 in)
2 Width of tractor			
Over trunnions	2640 mm (8 ft 8 in)	2640 mm (8 ft 8 in)	3491 mm (11 ft 5 in)
Without trunnions (standard track)	2440 mm (8 ft 0 in)	2440 mm (8 ft 0 in)	3201 mm (10 ft 6 in)
3 Machine height from tip of grouser:			
Stack	3143 mm (10 ft 4 in)	3143 mm (10 ft 4 in)	3193 mm (10 ft 6 in)
ROPS	3195 mm (10 ft 6 in)	3195 mm (10 ft 6 in)	3245 mm (10 ft 8 in)
4 Length of track on ground	2664 mm (8 ft 9 in)	2871 mm (9 ft 5 in)	3275 mm (10 ft 9 in)
5 Length of basic tractor	3860 mm (12 ft 8 in)	3860 mm (12 ft 8 in)	4247 mm (13 ft 11 in)
With following attachments add:			
Drawbar	217 mm (8.5 in)	217 mm (8.5 in)	251 mm (9.9 in)
Ripper Multi-Shank (tip at ground line)	1403 mm (4 ft 7 in)	1403 mm (4 ft 7 in)	—
Winch	517 mm (1 ft 8 in)	517 mm (1 ft 8 in)	397 mm (1 ft 4 in)
S Blade	1043 mm (3 ft 5 in)	—	1218 mm (4 ft 0 in)
SU Blade	1235 mm (4 ft 1 in)	1472 mm (4 ft 10 in)	—
A Blade	1147 mm (3 ft 9 in)	1349 mm (4 ft 5 in)	—
6 Height of grouser	65 mm (2.6 in)	65 mm (2.6 in)	65 mm (2.6 in)
7 Ground clearance	383 mm (1 ft 3 in)	383 mm (1 ft 3 in)	433 mm (1 ft 5 in)
Track pitch	203 mm (8.0 in)	203 mm (8.0 in)	203 mm (8.0 in)
Number of shoes per side	39	41	45
Number of rollers per side	6	7	8
Standard shoe	560 mm (22 in)	560 mm (22 in)	915 mm (36 in)
Ground contact area (standard track)	2.98 m ² (4,620 in ²)	3.22 m ² (4,972 in ²)	5.99 m ² (9,288 in ²)
Ground pressure*	0.614 kg/cm ² (8.74 psi)	0.623 kg/cm ² (8.90 psi)	0.362 kg/cm ² (5.15 psi)
8 Drawbar height (center of clevis from ground face of shoes)	576 mm (22.68 in)	576 mm (22.68 in)	576 mm (22.68 in)

*STD, XL with SU blade, with no rear attachments unless otherwise specified.

Bulldozer Specifications

Bulldozer Specifications	S		SU		A	
	STD	LGP	STD	XL	STD	XL
Blade capacity (SAE J1265)	3.89 m ³ (5.09 yd ³)	3.75 m ³ (4.90 yd ³)	5.61 m ³ (7.34 yd ³)	5.61 m ³ (7.34 yd ³)	3.93 m ³ (5.14 yd ³)	3.93 m ³ (5.14 yd ³)
Width (over end bits)	3360 mm (11.00 ft)	4063 mm (13.33 ft)	3260 mm (10.66 ft)	3260 mm (10.66 ft)	4166 mm (13.66 ft)	4166 mm (13.66 ft)
Height	1257 mm (50 in)	1101 mm (44 in)	1412 mm (56 in)	1412 mm (56 in)	1155 mm (45 in)	1155 mm (45 in)
Digging depth	473 mm (19 in)	655 mm (26 in)	473 mm (19 in)	459 mm (18 in)	506 mm (20 in)	524 mm (21 in)
Ground clearance	1104 mm (44 in)	1083 mm (43 in)	1104 mm (44 in)	1195 mm (47 in)	1142 mm (45 in)	1205 mm (47 in)
Maximum tilt	765 mm (30 in)	701 mm (28 in)	743 mm (29 in)	743 mm (29 in)	408 mm (16 in)	408 mm (16 in)
Weight*	2599 kg (5,730 lb)	2836 kg (6,252 lb)	2699 kg (5,950 lb)	2973 kg (6,554 lb)	3050 kg (6,724 lb)	3150 kg (6,945 lb)

*Includes push arms, blade, blade tilt cylinder(s), cutting edges and miscellaneous hardware components.

Undercarriage Specifications

Undercarriage	STD	XL	LGP
Track gauge	1880 mm (74 in)	1880 mm (74 in)	2286 mm (90 in)
Length of track on ground	2664 mm (8 ft 9 in)	2871 mm (9 ft 5 in)	3275 mm (10 ft 9 in)
Height of grouser	65 mm (2.6 in)	65 mm (2.6 in)	65 mm (2.6 in)
Track pitch	203 mm (8.0 in)	203 mm (8.0 in)	203 mm (8.0 in)
Number of shoes per side	39	41	45
Number of rollers per side	6	7	8
Number of carriers per side	—	1	1
Standard shoe width	560 mm (22 in)	560 mm (22 in)	915 mm (36 in)
Ground contact area (STD Track)	2.98 m ² (4,620 in ²)	3.22 m ² (4,972 in ²)	5.99 m ² (9,288 in ²)
Ground pressure*	0.614 kg/cm ² (8.74 psi)	0.623 kg/cm ² (8.90 psi)	0.362 kg/cm ² (5.15 psi)
Ground clearance	383 mm (1 ft 3 in)	383 mm (1 ft 3 in)	433 mm (1 ft 5 in)

*STD, XL with SU blade, with no rear attachments unless otherwise specified.

D6R Standard Equipment

Standard equipment may vary. Consult your Cat dealer for details.

ELECTRICAL

Alarm, backup
Alternator, 70 amp, brushless
Batteries, 2 maintenance free 12V (24V system)
Converter, 12V, 10 amp w/2 outlets
Connector, diagnostic
Lights, 4
Electric start, 24V
Horn, forward warning

OPERATOR ENVIRONMENT

Air conditioner, under-hood
Armrest, adjustable
Cab, ROPS/FOPS
Decelerator pedal
Differential steering control
Cat Monitoring System
Coolant temperature
Hydraulic temperature
Power train temperature
Fuel level
Tachometer
Hour meter
Diagnostics
Foot pads, dash
Heater
Hydraulic controls, pilot operated with electronic deactivation switch
Mirror, rearview
Radio ready
Seat, adjustable contour suspension
Seatbelt, retractable, 76 mm (3 in)
Throttle switch, electronic
Wipers, intermittent

POWER TRAIN

Cat C9 (8.8 L) diesel
NGMR (Next Generation Modular Radiator)
Air cleaner, pre-cleaner with strata tube dust ejector
Air filter with electronic service indicator
After-cooler, air to air (ATAAC)
Coolant, extended life
Fan, blower, direct drive
Final drives, 3-planet single reduction planetary
Fuel priming pump, electric
Muffler with mitered stack
Parking brake
Pre-screener
Starting aid, ether, automatic
Torque divider
Planetary transmission, mechanical power shift 3F/3R speeds
Turbocharger, waste-gate
Water separator

UNDERCARRIAGE

Carrier rollers, lifetime lubricated (XL and LGP)
Equalizer bar
Guards, end track guiding
Guards, center track guiding (LGP)
Idlers, lifetime lubricated
Rollers, lifetime lubricated track
Track roller frames, tubular
Track adjusters, hydraulic
Sprocket rim segments, replaceable
Track, HD SALT, moderate service
Standard arrangement: 560 mm (22 in), 39-section
XL arrangement: 560 mm (22 in), 41-section
LGP arrangement: 915 mm (36 in), 45-section

OTHER STANDARD EQUIPMENT

Parts book – CD ROM
Operation and Maintenance Manual – Paper
Engine enclosures, perforated
Front pull device
Guards, hinged bottom
Mounting, lift cylinder
Lift cylinder with lines, LH
Lift cylinder with lines, RH
Hood, perforated
Hydraulics, load sensing, dozer lift and tilt
Oil cooler, hydraulic
Product Link ready
Radiator doors, louvered, hinged, fan blast deflector
Sampling ports
Engine oil
Power train oil
Hydraulic oil
Engine coolant
Tool box
Vandalism protection
Cap locks for fluid compartments and battery box

Optional equipment may vary. Consult your Cat dealer for details.

ELECTRICAL

Alternator, 150 amp
Converter, 24 volt to 12 volt
Lights, additional 2 fwd

PRODUCT LINK COMMUNICATIONS

Cat Product Link – 321

GUARDS

Guard, crankcase and radiator, heavy duty
Guard, radiator, hinged, louvre
Screen, rear
Screen, side, cab
Sweeps w/lights
Striker bar, front, XL
Striker bars, front, angled LGP

OPERATOR ENVIRONMENT

Air conditioner, ROPS mounted
Canopy w/vinyl seat
Seat, cloth, air suspension

POWER TRAIN

Drains, ecology, power train
Grid, radiator core protector
Prescreener
Precleaner, turbine w/screen
Cold weather package
Cold weather package, extreme

UNDERCARRIAGE

Undercarriage, SystemOne, XL,
560 mm ES (41 sec)
Undercarriage, SystemOne, LGP,
914 mm ES (45 sec)

HEAVY-DUTY S & L TRACK

Track, 560 mm ES (39 sec) HD
Track, 610 mm MS (39 sec) HD
Track, 560 mm ES (41 sec) HD
Track, 610 mm MS (41 sec) HD
Track, 610 mm MS (41 sec) HD trap
Track, 914 mm ES (45 sec) HD, trap
Track, 991 mm Self-Cleaning (45 sec)

SYSTEMONE TRACK

Track, 610 mm ES (41 sec)
Track, 560 mm ES (41 sec)
Track, 914 mm ES (45 sec)

GUARDS, TRACK GUIDING, HEAVY-DUTY S & L

Guide, Track, Moderate Service, STD
Guide, Track, Moderate Service, XL
Guide, Track, Moderate Service, LGP
Guide/Guard, Track, Full Length, STD
Guide/Guard, Track, Full Length, XL
Guide/Guard, Track, Full Length, LGP
Guards, Track Guiding, SystemOne
Guide/Guard, Track, Full Length, XL
Guide/Guard, Track, Full Length, LGP

OTHER ATTACHMENTS

Drawbar, rigid long
Batteries, heavy duty and starter
Counterweight, rear
Counterweight, rear slab

SPECIAL ARRANGEMENTS

Waste Handling Arrangement, XL
Waste Handling Arrangement, LGP

TECHNOLOGY PRODUCTS

Installation, AccuGrade Ready w/Cab
Hydraulics, AccuGrade, w/o Rear Hyd
Hydraulics, AccuGrade, w/Rear Hyd
Mounting, AccuGrade, 6SU
Mounting, AccuGrade, 6SU XL
Mounting, AccuGrade, 6S LGP

BULLDOZERS

Bulldozer Package, STD, S/SU
Bulldozer Package, A
Bulldozer Package, XL, A
Bulldozer Package XL, SU
Bulldozer Package, LGP

BULLDOZER ATTACHMENTS

Blade, 6S
Blade, 6SU
Blade, 6A, STD
Blade, 6SU XL
Blade 6A, XL
Blade, 6S LGP
Blade, Landfill, 6SU XL w/Trash Rack
Blade, Landfill, 6S LGP w/Trash Rack

HYDRAULICS

Hydraulics, Ripper

RIPPER

6 Ripper, Multi-Shank, w/3 Curved Shanks

RIPPER ATTACHMENTS

Teeth, Straight, Set of 3

D6R Track-Type Tractor

For more complete information on Cat products, dealer services, and industry solutions, visit us on the web at www.cat.com

© 2010 Caterpillar Inc.
All rights reserved

Materials and specifications are subject to change without notice. Featured machines in photos may include additional equipment. See your Cat dealer for available options.

CAT, CATERPILLAR, SAFETY.CAT.COM, their respective logos, "Caterpillar Yellow" and the "Power Edge" trade dress, as well as corporate and product identity used herein, are trademarks of Caterpillar and may not be used without permission.

AEHQ6149-01 (12-2010)
Replaces AEHQ6149

