

325B L

Hydraulic
Excavator

CAT[®]



Operating weight

6.15 m (20'2") boom 3.2 m (10'6") stick

and std. 800 mm (32") track

27 530 kg 60,600 lb

Travel Speed (maximum)

5.0 km/h 3.1 MPH

Cat[®] 3116TA Diesel Engine (Gross)

132 kW 177 HP

(Flywheel power)

125 kW 168 HP

Hydraulics

Caterpillar hydraulics deliver power and control to keep material moving at high volume.



Dramatically increased control responsiveness aids operation and improves cycle time.

- Control movements better matched to hydraulic action for improved operator performance.
- Improved swing damping restrains drift and improves positioning during finishing and lifting applications reducing operator fatigue.

Sixteen percent larger boom cylinders and full-time nine percent increase in hydraulic relief pressure increases boom, stick, and bucket forces for better productivity, eighteen percent average higher lift capacity and wider range of workable material.

Hydraulic cross-sensing system improves productivity with faster implement speeds and quicker, stronger pivot turns.

- 100 percent of engine horsepower deliverable as hydraulic power.
- Full power to a single motor for strong, fast turns. Balanced power to two pumps for straight travel.

Boom regeneration circuit diverts oil within the cylinder to lower the boom, pumps have all pressure and flow available for other circuits.

Fine swing control cushions swing start and stop for better implement control.

Pump flow decreases when controls are in neutral for reduced fuel consumption and sound.

Auxiliary hydraulic valve is standard on the 325B for use with optional hydraulic circuits.

Auxiliary hydraulic flow control system option provides up to four programmable flow presets to precisely match hydraulic tool requirements (i.e., hammers, shears, processors, brush cutters, etc.).

Hydraulic cylinder snubbers at rod-end of boom cylinders and both ends of stick cylinders cushion shocks, reduce sound and increase cylinder life.

Cat's XT hose and reusable couplings meet the critical flexibility and strength demands of the 325B.

- O-ring face seal couplings provide positive sealing for reliable, leak-free connections.
- Hydraulic tank located closer to pumps for increased hydraulic efficiency.

Reach Boom Lift Capacities



Load Point Height



Load at Maximum Reach



Load Radius Over Front



Load Radius Over Side

3.20C STICK – 3200 mm (10'6")

BUCKET – 948 mm, 1.1 m³ (36", 1.5 yd³)

UNDERCARRIAGE – Long

SHOES – 800 mm (32") triple grouser

BOOM – 6150 mm (20'2")

Reach	kg	1.5 m (5.0 ft)		3.0 m (10.0 ft)		4.5 m (15.0 ft)		6.0 m (20.0 ft)		7.5 m (25.0 ft)		9.0 m (30.0 ft)		m	
		kg	lb	kg	lb	kg	lb	kg	lb	kg	lb	kg	lb		
9.0 m	kg													28.10	
30.0 ft	lb													28.10	
7.0 m	kg									13600	13600			8.9	
25.0 ft	lb									30000	30000			26.3	
6.0 m	kg									13910	8700			9.8	
20.0 ft	lb									31200	19200			31.4	
4.5 m	kg								7290	8960	10500	4000	3020	3200	10.3
15.0 ft	lb								16300	20000	23300	9000	6700	33.3	
3.0 m	kg													10.5	
10.0 ft	lb													34.2	
3.0 m	kg													10.4	
10.0 ft	lb													34.3	
1.5 m	kg													10.1	
5.0 ft	lb													33.6	
1.5 m	kg													8.9	
5.0 ft	lb													31.9	
3.0 m	kg													8.9	
10.0 ft	lb													29.1	
4.5 m	kg													8.9	
15.0 ft	lb													24.7	

* Indicates that the load is limited by hydraulic capacity rather than tipping capacity. Lift capacity ratings are based on SAE standard J11097. Rated loads do not exceed 87% of hydraulic lifting capacity or 75% of tipping capacity.

† Ground line

2.7C STICK – 2650 mm (8'8")

BUCKET – 948 mm, 1.1 m³ (36", 1.5 yd³)

UNDERCARRIAGE – Long

SHOES – 800 mm (32") triple grouser

BOOM – 6150 mm (20'2")

Reach	kg	3.0 m (10.0 ft)		4.5 m (15.0 ft)		6.0 m (20.0 ft)		7.5 m (25.0 ft)		m
		kg	lb	kg	lb	kg	lb	kg	lb	
7.5 m	kg									26.2
25.0 ft	lb									26.2
6.0 m	kg									8.3
20.0 ft	lb									29.5
4.5 m	kg									9.4
15.0 ft	lb									31.6
3.0 m	kg									10.0
10.0 ft	lb									32.6
1.5 m	kg									9.3
5.0 ft	lb									32.7
1.5 m	kg									9.6
5.0 ft	lb									31.9
1.5 m	kg									8.9
5.0 ft	lb									30.1
3.0 m	kg									7.8
10.0 ft	lb									27.1
4.5 m	kg									22.2
15.0 ft	lb									22.2

* Indicates that the load is limited by hydraulic capacity rather than tipping capacity. Lift capacity ratings are based on SAE standard J11097. Rated loads do not exceed 87% of hydraulic lifting capacity or 75% of tipping capacity.

† Ground line

Standard Equipment

Standard and optional equipment may vary. Consult your Caterpillar dealer for specifics.

Alternator, 52-amp	Literature compartment	Lights, working
Alarm, travel	Low fuel indicator light	Frame mounted, one
Automatic engine speed control	Joysticks, adjustable pilot-operated	Boom, both sides
Automatic swing parking brake	Prewired radio mounting	Cab mounted, two
Auxiliary hydraulic valve and auxiliary pump drive location	Positive filtered ventilation	Mirrors, frame and cab
Cab	Seat belt, retractable	Muffler
Air conditioner with automatic climate control	Seat, suspension, fully adjustable	Pre-start monitoring system
Ash tray with cigar lighter	Stationary skylight	Polycarbonate and glass windows
Coat hook	Storage compartment suitable for a lunch box cooler	Power Mode Selector
Drink holder	Travel control pedals	Power train
Floor mat	Two-speed auto shift travel	CAT 3116TA Diesel engine with 24-volt electric starting and air intake heater
Heater and defroster	Windshield wiper and washer	Water separator
Horn	Counterweight (5210 kg, 11,480 lb)	Work Mode Selector
Instrument panel with gauges	Door locks and caps locks with Caterpillar one-key security system	Undercarriage
Gauges and indicator lights for fuel level, coolant temperature and hydraulic oil temperature	Fine swing control	Hydraulic track adjusters
Light, interior	Fully pressurized hydraulic system	Track-type sealed undercarriage
	Hydraulic neutralizer lever for all controls	Idler and center section track guides
		800 mm (32") triple-grouser shoes

Optional Equipment

Optional equipment may vary. Consult your Caterpillar dealer for specifics.

Air conditioner, with automatic climate control, omission	Guards:	Rubber bumper side impact protection
Alarm, travel (required in U.S.)	Falling Object, for cab	Starting aid, cold weather
Booms:	Full length track guiding	Starting aid, ether
Reach 6.15 m (20'2")	Sprocket guiding	Straight travel third pedal option
Mass excavation 5.55 m (18'2")	Heavy duty, under house	Sticks:
Buckets, see pages 13 and 20	Vandalism protection	Reach 6.15 m (20'2") Boom:
Bucket linkage:	Hydraulic arrangements, basic auxiliary:	3200 mm (10'6") R/M3.2C
C family	One-way/two-way, includes two-pump combined flow	2650 mm (8'8") R2.7C
D family	Hydraulic lines, auxiliary for	Mass excavation 5.55 m (18'2") Boom:
Bucket sidecutters and tips	Reach Boom and sticks	3200 mm (10'6") R/M3.2C
Check valves:	Hydraulic tank suction line shut-off valve	2500 mm (8'2") M2.5D
Boom lowering	Quick Coupler	Sun screen
Cooling system, high ambient		Track:
Easy Shift Control Pattern Changer		600 mm (24") double-grouser shoes
		700 mm (28") double-grouser shoes

325B Bucket Specifications and Compatibility

	Capacity*		Width		Tip Radius		Weight		Teeth Qty	Reach		Mass Ex.	
	m ³	yd ³	mm	in	mm	in	kg	lb		3.2C (10'6")	2.7C (8'8")	3.2C (10'6")	2.5D (8'3")
C Buckets for Reach Linkage													
Heavy Duty (HD)	0.7	0.88	775	30	1638	64.5	792	1,742	3	●	●	●	—
	0.9	1.25	948	36	1638	64.5	888	1,954	4	●	●	●	—
	1.1	1.5	1098	42	1638	64.5	962	2,116	5	●	●	●	—
	1.2	1.5	1378	54	1518	60	1082	2,380	5	●	●	●	—
	1.3	1.75	1248	48	1638	64.5	1037	2,281	5	●	●	●	—
	1.5	2.0	1395	54	1638	64.5	1119	2,462	6	●	●	●	—
	1.7	2.25	1522	60	1638	64.5	1195	2,629	7	●	●	●	—
	1.9	2.5	1680	66	1638	64.5	1281	2,818	7	○	○	○	—
General Purpose (GP)	0.8	1.12	775	30	1778	70	803	1,767	3	●	●	●	—
	1.1	1.5	948	36	1778	70	890	1,958	5	●	●	●	—
	1.3	1.75	1098	42	1778	70	951	2,092	5	●	●	●	—
	1.6	2.12	1248	48	1778	70	1046	2,301	6	●	●	●	—
	1.9	2.5	1395	54	1778	70	1116	2,455	7	○	○	○	—
Ditch Cleaning (DC)	1.1	1.5	1676	66	1132	45	813	1,789	—	●	●	●	—
	1.2	1.62	1829	72	1132	45	860	1,892	—	●	●	●	—
Heavy Duty Rock (HDR)	0.9	1.25	948	36	1638	64.5	1000	2,200	4	●	●	●	—
	1.1	1.5	1098	42	1638	64.5	1084	2,385	5	●	●	●	—
	1.3	1.75	1248	48	1638	64.5	1168	2,570	5	●	●	●	—
Rock Ripping (RR)	0.6	0.75	850	33	1660	65	1084	2,385	5	X	●	X	—
D Buckets for Mass Ex. Linkage													
Heavy Duty (HD)	0.7	1.0	775	30	1764	69	875	1,925	3	—	—	—	●
	0.9	1.25	925	36	1764	69	968	2,130	3	—	—	—	●
	1.2	1.5	1098	42	1764	69	1079	2,374	4	—	—	—	●
	1.4	1.88	1246	48	1764	69	1206	2,653	5	—	—	—	●
	1.5	2.0	1440	57	1695	67	1330	2,926	5	—	—	—	●
	1.6	2.12	1400	55	1764	69	1306	2,873	5	—	—	—	●
	1.8	2.5	1540	60	1764	69	1407	3,095	6	—	—	—	●
	2.0	2.75	1695	66	1764	69	1493	3,285	6	—	—	—	●
	2.2	3.0	1820	72	1764	69	1620	3,564	7	—	—	—	○
General Purpose (GP)	0.8	1.12	775	30	1854	73	947	2,083	3	—	—	—	●
	1.1	1.5	925	36	1854	73	1024	2,253	3	—	—	—	●
	1.4	1.88	1098	42	1854	73	1116	2,455	5	—	—	—	●
	1.7	2.25	1246	48	1854	73	1146	2,521	5	—	—	—	●
	1.9	2.5	1400	55	1854	73	1192	2,622	5	—	—	—	●
	2.2	3.0	1540	60	1854	73	1400	3,080	6	—	—	—	●
Ditch Cleaning (DC)	1.7	2.25	1676	66	1424	56	1192	2,622	—	—	—	—	●
	1.8	2.5	1829	72	1424	56	1239	2,726	—	—	—	—	●
Heavy Duty Rock (HDR)	1.2	1.5	1098	42	1764	69	1294	2,847	4	—	—	—	●
	1.4	1.88	1246	48	1764	69	1437	3,161	5	—	—	—	●
	1.6	2.12	1400	55	1764	69	1553	2,417	5	—	—	—	●
Rock Ripping (RR)	0.7	0.88	900	35	1746	69	1123	2,471	5	—	—	—	●

Assumptions for maximum material density rating:

1. Front linkage fully extended at ground line

2. Bucket curled

3. 100% bucket fill factor

* Based on SAE J296, some calculations of capacity specs fall on borderlines. Rounding may allow two buckets to have the same English rating, but different metric ratings.

● 2,000 kg/m³ (3,400 lbs/yd³) max material density

○ 1,800 kg/m³ (3,000 lbs/yd³) max material density

○ 1,500 kg/m³ (2,500 lbs/yd³) max material density

— Not Available

X Not Recommended

Mass Excavator Working Ranges

Mass (M) boom configuration

Feet Meters

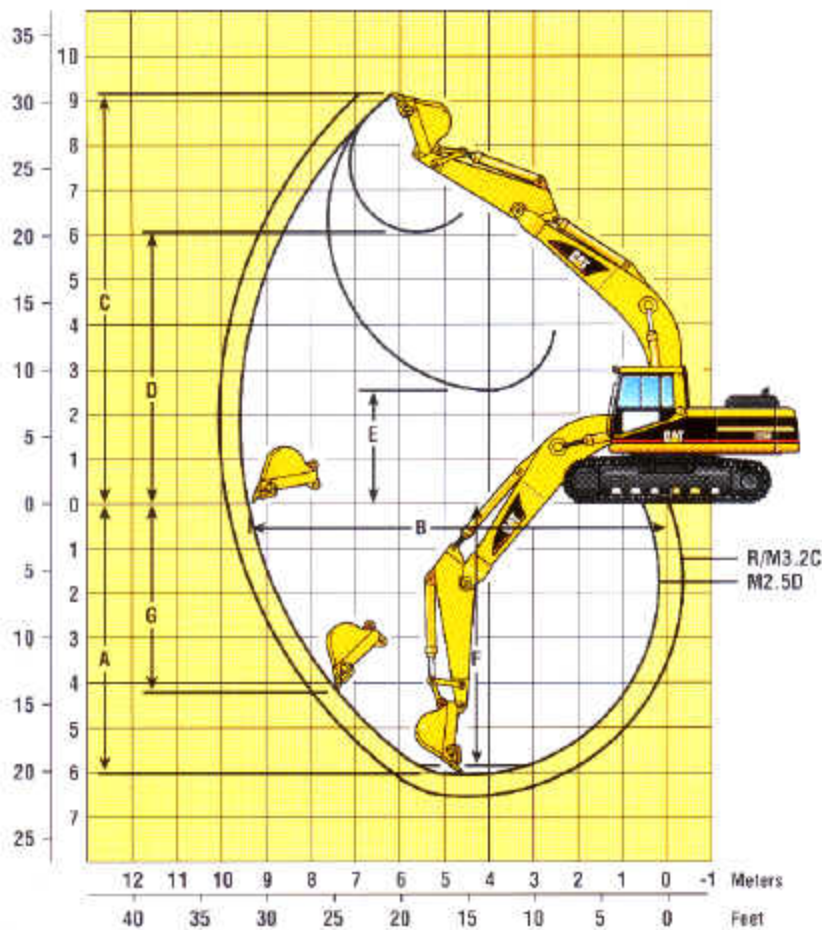

Stick Length	R/M3.2C m (10'6") ^{**}	M2.5D m (8'2") [*]
A Maximum Digging Depth	6.57 m (21'6")	6.04 m (19'10")
B Maximum Reach at Ground Level	9.91 m (32'6")	9.38 m (30'9")
C Maximum Cutting Height	9.47 m (31'1")	9.15 m (30'0")
D Maximum Loading Height	6.66 m (21'10")	6.06 m (19'11")
E Minimum Loading Height	2.00 m (6'7")	2.53 m (8'3")
F Maximum Depth Cut for 244 mm (8") Level Bottom	6.40 m (21'0")	5.85 m (19'2")
G Maximum Vertical Wall Digging Depth	4.87 m (16'0")	4.21 m (13'10")
Bucket Digging Force (SAE)	164 kN (37,000 lb)	195 kN (43,800 lb)
Stick Digging Force (SAE)	117 kN (26,400 lb)	139 kN (31,300 lb)

** All measurements shown are for machines equipped with the 1.2 m³ (1.5 yd³) bucket

* All measurements shown are for machines equipped with the 1.5 m³ (2.0 yd³) bucket

Reach Excavator Working Ranges

Reach (R) boom configuration

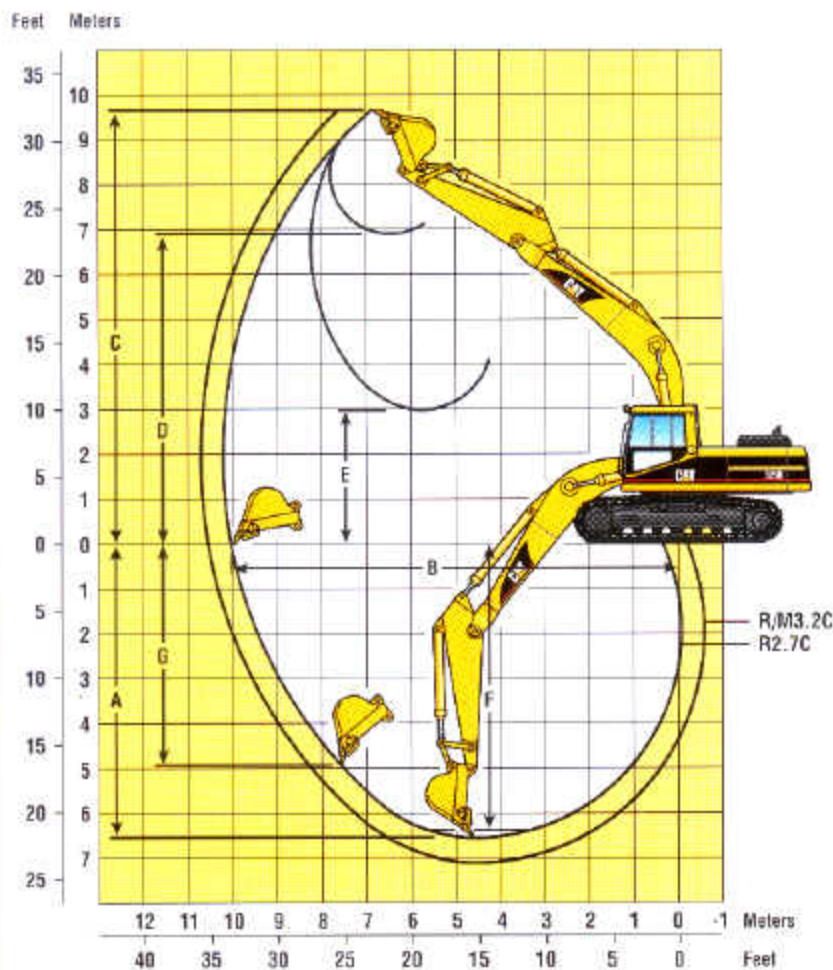

Stick Length	R/M3.2C m (10'6")*	R2.7C m (8'8")*
A Maximum Digging Depth	7.12 m (23'4")	6.57 m (21'7")
B Maximum Reach at Ground Level	10.55 m (34'7")	10.04 m (32'11")
C Maximum Cutting Height	9.88 m (32'5")	9.68 m (31'9")
D Maximum Loading Height	7.08 m (23'3")	6.87 m (22'6")
E Minimum Loading Height	2.42 m (7'11")	2.97 m (9'9")
F Maximum Depth Cut for 244 mm (8') Level Bottom	6.96 m (22'10")	6.38 m (20'11")
G Maximum Vertical Wall Digging Depth	5.36 m (17'7")	4.95 m (16'3")
Bucket Digging Force (SAE)	164 kN (37,000 lb)	163 kN (36,700 lb)
Stick Digging Force (SAE)	117 kN (26,400 lb)	135 kN (30,400 lb)

* All measurements shown are for machines equipped with the 1.2 m³ (1.5 yd³) bucket

Dimensions and Weights

All dimensions are approximate.

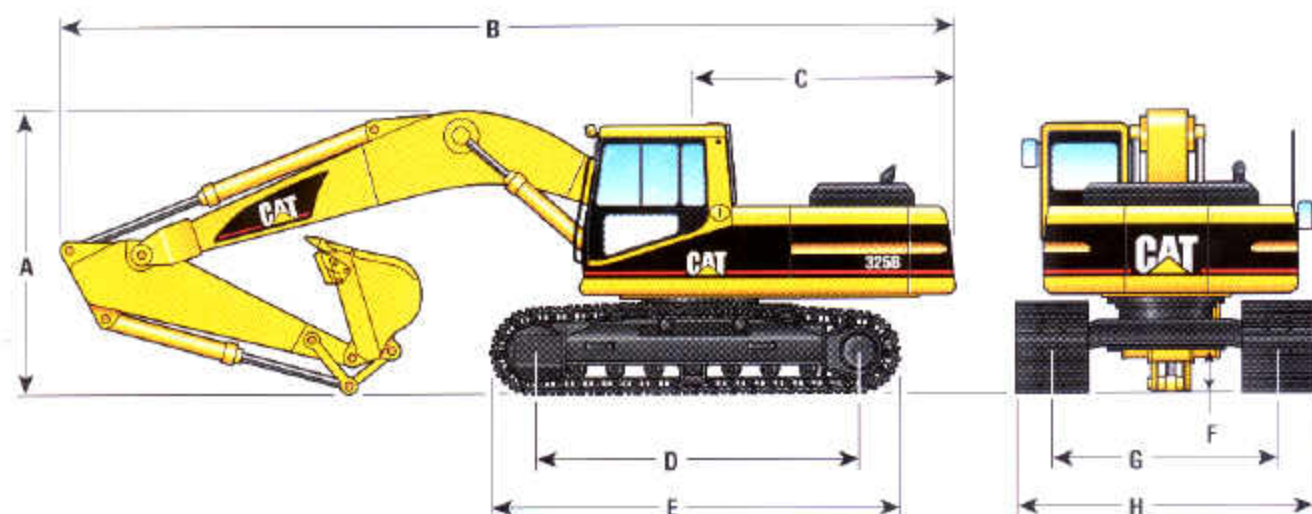

Reach Boom 6.15 m (20'2")	R/M3.2C m (10'6") Stick	R2.7C m (8'8") Stick
A Shipping height	3270 mm (10'9")	3270 mm (10'9")
B Shipping length	10 290 mm (33'9")	10 290 mm (33'9")
C Tail swing radius (Reach and Mass Boom)	3050 mm (10')	3050 mm (10')
D Length to centers of rollers (Reach and Mass Boom)	3795 mm (12'5")	3795 mm (12'5")
E Track length (Reach and Mass Boom)	4660 mm (15'3")	4660 mm (15'3")
F Ground clearance (Reach and Mass Boom)	480 mm (1'7")	480 mm (1'7")
G Track gauge (Reach and Mass Boom)	2590 mm (8'6")	2590 mm (8'6")
H Transport width (Reach and Mass Boom) with 800 mm (32") Shoes	3390 mm (11'1")	3390 mm (11'1")

Mass Boom 5.55 m (18'2")	R/M3.2C m (10'6") Stick	M2.5D m (8'2") Stick
A Shipping height	3190 mm (10'6")	3460 mm (11'4")
B Shipping length	9700 mm (31'10")	9710 mm (31'10")

Operating Weight	600 mm (24") Shoes		700 mm (28") Shoes		800 mm (32") Shoes	
	kg	lb	kg	lb	kg	lb
Reach Boom 6.15 m (20'2")						
Sticks:						
3.2 m (10'6")	26 940	59,300	27 320	60,200	27 530	60,600
2.7 m (8'8")	26 860	59,200	27 230	60,000	27 450	60,500
Mass Boom 5.55 m (18'2")						
Sticks:						
3.2 m (10'6")	27 010	60,800	27 390	60,300	27 600	60,800
2.5 m (8'3")	27 370	60,300	27 740	61,100	27 950	61,600

Ground Pressure: Reach Boom, 3.2 m (10'6") Stick	600 mm (24") Shoes	700 mm (28") Shoes	800 mm (32") Shoes
	53.6 kPa	7.8 psi	46.6 kPa
			6.8 psi
			41.1 kPa
			6.0 psi

Steering

Two rocker pedals with detachable hand levers control steering and travel functions.

Controls

- controls are pilot-operated for reduced efforts
- left pedal and lever control left track; right pedal and lever control right track
- when idlers are in front, pushing both pedals or levers forward moves the excavator straight ahead
- when the idlers are in front, rocking both pedals or pulling both levers backward moves the excavator straight back
- moving one pedal or lever more than the other, either forward or backward, results in a gradual turn
- moving one pedal or lever forward and the other pedal or lever backward counter-rotates the tracks for spot turns
- optional straight travel third pedal drives both tracks forward or reverse at the same speed. Steering adjustments can be made by simultaneously pressing right or left pedal.

Implement Controls

Two joystick hand levers actuate boom, stick, bucket and swing (SAE pattern).

Boom/Bucket Controls (Right Joystick)

- move forward and backward to lower and raise boom
- move left and right to control bucket curl and dump
- button on top is one-touch low idle

Stick/Swing Controls (Left Joystick)

- move forward and backward to move stick out and in
- move left and right to control direction of swing
- button on top controls horn

Brakes

Meets the following standards:
SAE J1026-APR90

Service and parking brake features

- wet, multiple-disc brakes are used on the final drive input shafts
- spring-applied, hydraulically released
- actuating a travel control simultaneously releases the brakes
- when the controls are released, the brakes automatically apply

Track

Caterpillar designed and built track-type undercarriage.

Track width

standard	800 mm (32")	triple grouser
optional	600 mm (24")	double grouser
	700 mm (28")	double grouser

Ground clearance 480 mm (17")

Swing Mechanism

Hydrostatic with independent planetary reduction.

Ratings

Swing Torque	76 kN-m (56,080 lb-ft)
Maximum Swing Speed	10.0 rpm

Features

- the swing mechanism is driven by a pinion gear sealed in a grease bath through a double-reduction planetary gear set.

Service Refill Capacities

	L	Gallons
Fuel Tank	420	111
Cooling System	31.5	8.3
Engine Oil	20	5.3
Swing Drive	10	2.6
Final Drive (each)	8	2.1
Hydraulic system (including tank)	310	82
Hydraulic tank	175	46

Major Component Weights

Booms: includes lines, boom cylinders, stick cylinder

	kg	lb
Reach 6.15 m (20'2")	2740	6030
Mass 5.55 m (18'2")	2810	6190

Sticks: includes bucket cylinder and bucket linkage

	kg	lb
R3.2C	1320	2910
R2.7C	1240	2730
M2.5D	1430	3160
Counterweight	5210	11,480

Engine

Caterpillar four-cycle 3116TA quad turbo-charged and aftercooled, diesel engine.

Ratings at 2000 rpm*	kW	HP
Gross power	132	177
Net power	125	168

The following ratings apply at 2000 rpm when tested under the specified standard conditions for the specified standard:

Net power	kW	HP
Caterpillar	125	168
ISO 9249	125	168
SAE J1349	125	168
EEC 80/1269	125	168

Dimensions

Bore	105 mm	4.13 in.
Stroke	127 mm	5.0 in.
Displacement	6.6 liters	403 in ³

Hydraulic System

Two variable displacement, axial-piston pumps power the boom, stick, swing, bucket, auxiliary and travel circuits. One single-section, gear-type pump powers the pilot circuit.

Main Implement System

Maximum flow	2 x 214 liters/min (2 x 56.5 gpm)
Maximum pressure	
Implements	34 300 kPa (4980 psi)
Travel	34 300 kPa (4980 psi)
Swing	29 400 kPa (4250 psi)

Pilot System

Maximum flow	41 liters/min (10.8 gpm)
Maximum pressure	4100 kPa (595 psi)

Cylinders, Bore and Stroke

Boom (2)	140 x 1407 mm (5.5" x 4'7")
Stick (1)	150 x 1569 mm (5.9" x 5'2")
Bucket (1)	
C family	130 x 1156 mm (5.1" x 3'10")
D family	150 x 1156 mm (5.9" x 3'10")

Features

- main hydraulic pumps are electronically controlled and dependent on engine speed
- power modes match hydraulic output to application severity

*Power rating conditions

- based on standard air conditions of 25°C (77°F) and 99 kPa (29.32 in Hg) dry barometer
- used 35° API gravity fuel having an LHV of 42 780 kJ/kg (18,390 Btu/lb) when used at 30°C (86°F) [ref. a fuel density of 838.9 g/L (7.001 lb/ U.S. gal)]
- net power advertised is the power available at the flywheel when the engine is equipped with fan, air cleaner, muffler, and alternator

Drive

Drive system is fully hydrostatic.

Ratings

Maximum drawbar pull	215 kN	(48,350 lb)
Maximum travel speed	5.0 kph	(3.1 mph)
Maximum gradeability (based on engine operation)		70%

Features

- each track is driven by one independent, automatic shifting, two-speed bent-axis piston motor via integral planetary final drives
- multiple disc brakes have increased braking capacity, are spring-engaged and pressure released
- each drive module is well integrated into the roller frame for total protection

Cab/FOGS

Bolt-on Falling Object Guard System (FOGS) is available as an attachment.

Cab Certifications

- Optional Falling Object Guard System is designed to protect the operator from falling objects, and is certified under SAE J1356 Feb 88 and ISO 3449-1984 specifications.

Note

When properly installed and maintained, the cab offered by Caterpillar, when tested with doors and windows closed according to ANSI/SAE J1166 MAY90, meets OSHA and MSHA requirements for operator sound exposure limits in effect at time of manufacture.

Buckets

Increased offerings of buckets help optimize machine performance.

Caterpillar buckets provide increased service life with reduced repair costs. All buckets except ditch cleaning have the following features:

- Dual Radius design for increased heel clearance and reduced wear.
- Robot welding of hinge assembly (Cat and Balderson) and other critical areas (Cat only) for increased weld penetration and longer life.
- High strength and heat treated steel in high wear areas.

1 Heavy Duty (HD) Buckets for digging in moderate to hard abrasive materials. Differences from GP buckets are as follows:

- Larger Ground Engaging Tools (GET), thicker cutting edges and thicker bottom and side wear plates improve performance in demanding applications.

General Purpose (GP) Buckets (from Balderson) are best for digging in soft to hard ground with low to moderate abrasive materials.

2 Heavy Duty Rock (HDR) Buckets perform best when digging fragmented rock, frozen ground, caliche and highly abrasive materials. Differences from HD buckets are as follows:

- Additional, thicker wear plates extend beyond side plates for corner and rear dent protection and improved durability.
- Larger side plates provide additional dent protection.
- Sidebar protectors decrease sidebar wear.

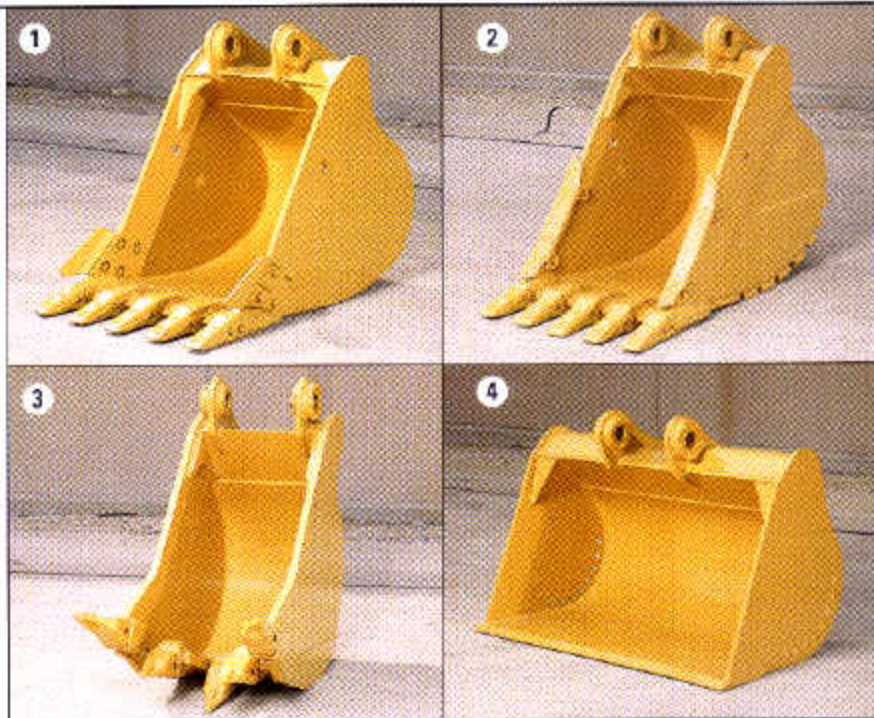

3 Heavy Duty Rock Ripping (RR) Buckets dig hard rock and work in areas where material is virgin or poorly prepared. Differences from HDR buckets are as follows:

- Stepped tooth design allows one or two tip penetration for higher break-out forces and keeps the trench floor flat.
- Thicker side wear plates, cutting edges and larger GET (C family only) mean additional wear life.

4 Ditch Cleaning (DC) Buckets (from Balderson) are wide shallow buckets for bank forming, ditch cleaning and finishing.

Mechanical quick coupler speeds attachment changes.

- Actuator mechanism is sealed, lubricated and has high strength, heat-treated steel wear surfaces for use in severe applications.
- The quick coupler allows buckets and attachments from the 320 through the 330 to be interchanged.

Booms, Sticks and Attachments

The 325B has designed-in flexibility to help bring higher production and efficiency to your jobs.

Select the right combination for the job with your Cat dealer and you'll help ensure top production from the start.

The choice of two booms and three sticks, plus a wide selection of buckets and attachments, means the 325B offers a large combination of reach and digging forces for optimum versatility.

Choose from a variety of work tools such as hammers, shears, rotators, grapples or crushers. Ask your Cat dealer for information on attachments or special configurations.

The Reach Boom (R) 6.15 m (20'2") features an optimum design that maximizes digging envelopes with two stick choices.

- The R/M3.2C stick gives the largest working envelope with medium (C-sized) buckets.
- The R2.7C stick uses the higher capacity buckets and is best suited to trenching, excavation and general construction applications.

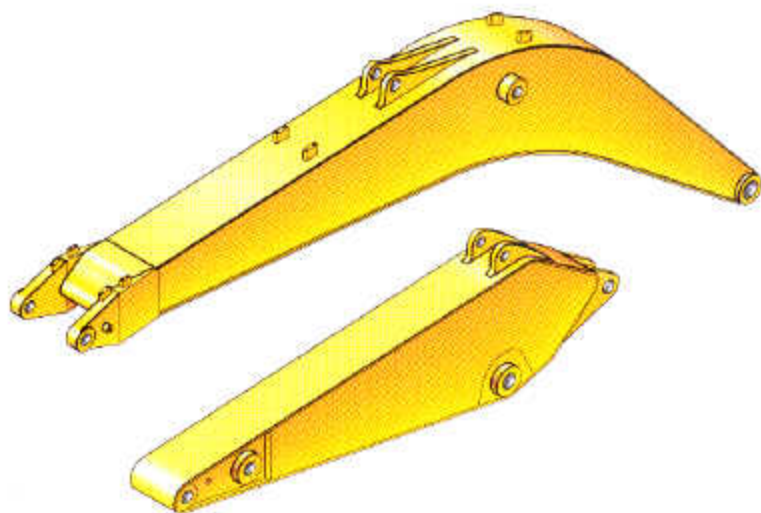

The Mass Excavator (M) Boom 5.55 m (18'0") maximizes productivity. The M version offers significantly higher digging forces to allow use of larger buckets.

- The R/M3.2C stick gives the largest working envelope with the Mass Excavator (M) Boom and C-sized buckets.
- The M2.5D stick has been specifically designed for large earth moving applications and uses D-sized buckets.

1 Caterpillar side impact protection (optional) bumpers help protect machines from damage, reducing repair and service time. Rubber is bonded to high-strength steel plates and bolted to the upper frame.



Undercarriage

Durable undercarriage absorbs stresses and provides excellent stability.



Precision robotic welding ensures a quality weld every time. Those welds increase rigidity, reduce internal stresses and enhance durability for the chassis and track roller frames.

Heavy-duty, X-shaped chassis design. Cat undercarriage components are purposely oversized to offer heavy-duty performance and durability.

Strutted track links are sealed for longer life. Track rollers, carrier rollers and idlers are also sealed and lubricated for excellent service life.

Smoother autoshifting two-speed travel motors offer 11 percent increase in top travel speeds and plenty of pull on slopes or turns.

Long (L) undercarriage maximizes stability and lifting capacity. Long, wide and sturdy undercarriage offers a very stable work platform.

Steeper track roller frame design and the elimination of a ledge at carbody and roller frame juncture reduces material build-up and makes digging out easier.

Standard idler guards and center track guides maintain track alignment. Optional sprocket guiding guards or full length track guiding guards are available for additional protection on steep side slopes.

Structures

The 325B structural components are the backbone of the machine's durability.



1 Advanced carbody design stands up in the toughest applications.

- Modified X-shaped, box-section carbody provides excellent resistance to torsional bending.
- Upper structure weight and stresses are distributed evenly across the full length of the track roller frame.
- Smooth transitions and long welds reduce stresses at the carbody-to-roller frame junctions for excellent durability.
- Robot welding ensures consistent, high-quality welds throughout the manufacturing process.

Robot-welded track roller frames are press-formed, pentagonal units to deliver exceptional strength and service life.

2 Rugged main frame is designed for maximum durability and efficient use of materials.

- Outer frame utilizes curved side rails, which are die-formed, for excellent uniformity and strength throughout the length.
- Box section channels improve upper frame rigidity under the cab.
- Inverted U-channels span the width of the main frame and are formed, rather than fabricated, for superior strength and reduced weight.
- Boom tower and main rails are constructed of solid, high-tensile strength steel plates.
- Boom foot and engine mount areas reinforced for additional strength.
- Sheet metal supporting structure is improved by integrating the mounting into upper frame structure.

Caterpillar excavator booms and sticks are built for performance and long service life.

- Castings and forgings are used at high stress areas such as boom nose, boom foot, boom cylinder and stick foot.
- Large, welded, box-section structures with thick, multi-plate fabrications in high-stress areas.
- Construction allows structures to flex and dissipate stresses.
- All booms and sticks are stress relieved to maximize material strength and durability, while minimizing weight for improved performance.

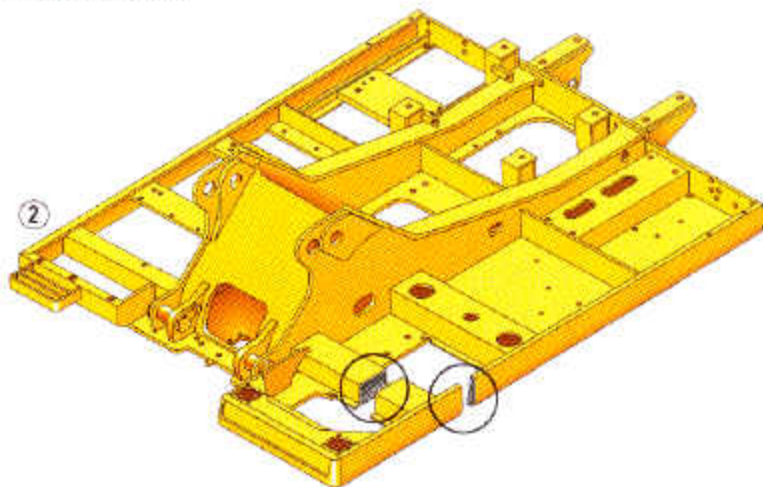

Cat 3116TA Engine

The six cylinder turbo-charged and aftercooled engine is built for power, reliability, economy and low emissions.



Automatic Engine Control with convenient one-touch command. Three-stage control maximizes fuel efficiency and reduces sound levels.

- When placed in the "OFF" mode, if a no-load condition or light-load condition continues more than three seconds, the automatic engine control reduces engine speed by 100 rpm.
- When placed in the "ON" mode, if a no-load condition or light-load condition continues more than three seconds, the automatic engine control reduces engine speed from high idle to 1300 rpm.
- At any time, the operator can activate a switch on the top of the right control lever to reduce the engine speed to 950 rpm. This feature, referred to as one-touch idle, can be used both to conserve fuel and to reduce engine sound levels. Activate switch again to return to previous level.

High displacement, low rpm rating and conservative HP rating mean longer service hours with less downtime for maintenance and repair.

Turbo-charged and aftercooled to increase engine power by burning fuel with greater efficiency.

Two-piece pistons are used for high durability, good fuel efficiency and low vibration. These pistons better withstand higher internal cylinder pressure.

Meets all current and proposed worldwide emissions standards up to the year 2001.

Air intake heating is standard on the 325B for easier cold starts. When coolant temperature is above 10° C (50° F) the air intake heater does not operate, below that temperature the length of the heating period automatically adjusts to the temperature.

Fuel tank capacity has been increased to allow 15 hours of continuous operation under normal load.

Mass Excavation Boom Lift Capacities



Load Point
Height



Load at
Maximum Reach



Load Radius
Over Front



Load Radius
Over Side











3.20C STICK – 3200 mm (10'6")

BUCKET – 948 mm, 1.1 m³ (36', 1.5 yd³)

UNDERCARRIAGE – Long

SHOES – 800 mm (32") triple grouser

BOOM – 5500 mm (18'2")

	1.5 m (5.0 ft)		3.0 m (10.0 ft)		4.5 m (15.0 ft)		6.0 m (20.0 ft)		7.5 m (25.0 ft)			m ft	
													
7.0 m 23.0 ft											*2630 *5,900	*2620 *5,900	8.2 25.0
6.0 m 20.0 ft									*4590 *8,800	*4590 *8,800	*2510 *5,600	*2510 *5,600	9.1 29.1
4.5 m 15.0 ft							*7930 *16,300	6990 15,000	*6270 *13,200	4710 10,100	*2510 *5,900	*2510 *5,900	9.6 31.1
3.0 m 10.0 ft			*17,320 *38,900	*17,320 *38,900	*11,250 *24,200	10,700 23,000	*9990 *19,200	6670 14,300	8590 15,000	4570 9,800	*2610 *5,700	*2610 *5,700	9.8 32.2
1.5 m 5.0 ft			*7060 *16,800	*7060 *16,800	*3,950 *30,100	9930 21,400	9850 21,100	6320 13,600	4900 14,600	4000 9,400	*2820 *6,000	*2820 *6,000	9.8 32.3
10.0 m 33.0 ft			*7920 *18,200	*7920 *18,200	*16,670 *33,400	9420 20,300	9540 20,500	6060 13,000	8850 14,300	4380 9,100	*3170 *6,700	2940 8,400	9.4 31.8
10.0 m 33.0 ft			*18,200 *41,000	*18,200 *41,000	*32,200 *70,400	19,800 44,000	20,100 45,000	12,700 28,200	14,100 31,300	9,000 20,000	*7,700 *17,000	7,000 15,500	29.6 91.3
10.0 m 33.0 ft			*11,400 *25,800	*11,400 *25,800	*19,900 *44,000	14,600 32,200	14,600 32,200	9,240 20,500	9,240 20,500	5900 13,000	*4830 *10,700	4220 9,400	7.6 23.3
10.0 m 33.0 ft			*25,800 *57,000	*25,800 *57,000	*41,000 *90,400	26,000 58,000	26,000 58,000	16,800 37,200	16,800 37,200	12,700 28,200	*9,700 *21,500	8,400 18,700	26.8 81.6
4.5 m 15.0 ft			*17,330 *37,100	*17,330 *37,100	*12,170 *26,900	9470 20,400	9370 20,400	6140 13,600			*7,400 *16,400	*7,400 *16,400	21.5 66.3

* Indicates that the load is limited by hydraulic capacity rather than tipping capacity. Lift capacity ratings are based on SAE standard J1097. Rated loads do not exceed 87% of hydraulic lifting capacity or 75% of tipping capacity.

† Ground line.











2.50D STICK – 2500 mm (8'2")

BUCKET – 1098 mm, 1.4 m³ (42', 1.88 yd³)

UNDERCARRIAGE – Long

SHOES – 800 mm (32") triple grouser

BOOM – 5500 mm (18'2")

	1.5 m (5.0 ft)		3.0 m (10.0 ft)		4.5 m (15.0 ft)		6.0 m (20.0 ft)		7.5 m (25.0 ft)			m ft	
													
7.5 m 25.0 ft											*3740 *8,400	*3740 *8,400	7.3 22.8
6.0 m 20.0 ft							*7400 *16,200	6750 14,400			*2680 *7,900	*2680 *7,900	8.4 26.7
4.5 m 15.0 ft					*9690 *21,300	9690 21,300	*9100 *20,200	8500 13,500	*6450 *14,200	4320 9,000	*3600 *8,200	3200 7,300	8.0 29.0
3.0 m 10.0 ft					*12,310 *26,500	10,110 21,800	*9340 *20,200	6980 13,500	6640 14,200	4230 9,000	*3770 *8,200	2940 6,600	8.2 30.1
1.5 m 5.0 ft					*7400 *16,200	6750 14,400	*6200 *13,600	5600 12,300	4060 9,000	3100 6,800	*2100 *4,600	1910 5,000	8.2 25.3
10.0 m 33.0 ft					*31,400 *69,400	26,200 58,000	*29,300 *64,000	20,800 46,000	*13,900 *30,600	9,200 20,400	*11,500 *25,500	7,500 16,600	30.2 92.3
10.0 m 33.0 ft					*15,150 *32,400	9610 21,400	9020 19,800	5740 12,300	6390 12,700	3990 8,600	*4660 *10,300	3100 6,600	8.8 29.3
10.0 m 33.0 ft					*13,150 *29,000	10,800 23,900	*13,020 *28,700	9670 21,300	8030 17,800	5740 12,400	*4130 *9,000	*4130 *9,000	8.6 26.3
10.0 m 33.0 ft					*17,700 *39,000	*17,700 *39,000	*30,400 *66,800	*30,400 *66,800	*32,200 *70,400	19,200 42,600	*11,500 *25,500	7,500 16,600	27.3 83.3
10.0 m 33.0 ft					*17,700 *39,000	*17,700 *39,000	*30,400 *66,800	*30,400 *66,800	*32,200 *70,400	19,200 42,600	*11,500 *25,500	7,500 16,600	27.3 83.3
4.5 m 15.0 ft					*9480 *20,900	9480 20,900	*9480 *20,900	8480 18,700			*7,400 *16,400	*7,400 *16,400	8.6 26.3

* Indicates that the load is limited by hydraulic capacity rather than tipping capacity. Lift capacity ratings are based on SAE standard J1097. Rated loads do not exceed 87% of hydraulic lifting capacity or 75% of tipping capacity.

† Ground line.