

990H

Wheel Loader



Engine

Engine Model	Cat® C27 ACERT®	
Gross Power	512 kW	687 hp
Net Power – ISO 14396	499 kW	669 hp
Net Power – EEC 80/1269	468 kW	627 hp

Operating Specifications

Rated Payload	15 tonnes	16.5 tons
Operating Weight	77 842 kg	171,642 lb
Buckets		
Bucket Capacities	8.4 m ³ -9.2 m ³	11 yd ³ -12 yd ³

990H Features

Productivity

Productivity is critical to your bottom line. The 990H offers features and systems that help to improve performance and lower your cost-per-ton.

Efficiency

From everyday production to daily maintenance, the 990H offers features to minimize cost.

Reliability

The 990H offers field proven components and systems, high hour machine life standards and multiple rebuild options for continued uptime and long machine life.

Operator Comfort

From low effort controls to reduced operator sound, the 990H has a number of features that minimize operator fatigue, resulting in a safe, productive work site.

Serviceability

Designed to ensure minimal downtime with attention to ground level access and grouped service points, the 990H maximizes production and minimizes service time.

Sustainability

With a number of features and options that lower customer cost and waste, the 990H can assist you in being an environmental steward.

Safety

The 990H offers a number of features that optimize visibility, allow for safe machine service and enhance operator health and well-being.

Contents

Productivity	3
Fuel Efficiency	4
Reliability	5
Operator Comfort	6
Technology Solutions	7
Buckets and Ground Engaging Tools.....	8
Serviceability	9
Customer Support.....	10
Sustainability	11
Safety	12
990H Wheel Loader Specifications.....	13
990H Standard Equipment	18
990H Optional Equipment.....	19



The Cat® 990H is a proven performer in quarry and industrial applications around the world. With superior quality and world class productivity, the 990H provides the lowest cost per ton of any wheel loader in its size class.

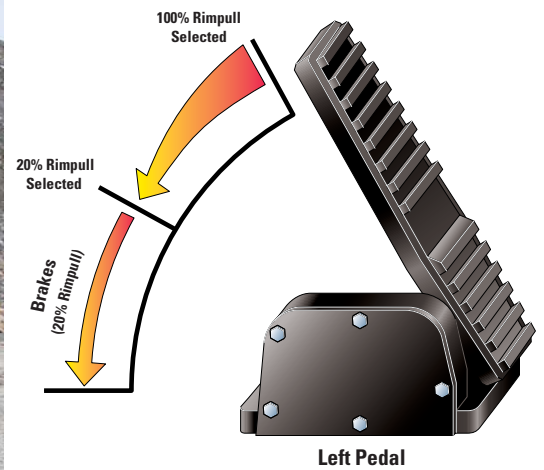

Productivity

Designed with the right features to meet the daily demands of your job site

Engine

The Cat® C27 engine with ACERT® Technology is U.S. EPA Tier 3 and EU Stage III compliant. It features increased horsepower and efficient fuel management for quick response, high productivity and exceptional service life. A sculpted cylinder block provides greater strength and is lighter weight.

Impeller Clutch Torque Converter (ICTC) and Rimpull Control System (RCS)

ICTC combined with the RCS allows the operator maximum flexibility in the modulating rimpull.

- Left brake pedal modulates rimpull from 100 to 20 percent for reduced tire slippage and wear. After 25 percent is achieved, further pedal travel applies the brake.
- RCS reduces the potential for wheel slippage without reducing the hydraulic efficiency. An in-cab switch allows the operator to set percentage of maximum rimpull to meet operating conditions. Four settings are available, and operators can set rimpull at 70, 80, 90 and 100 percent.

Fuel Efficiency

Fuel Management

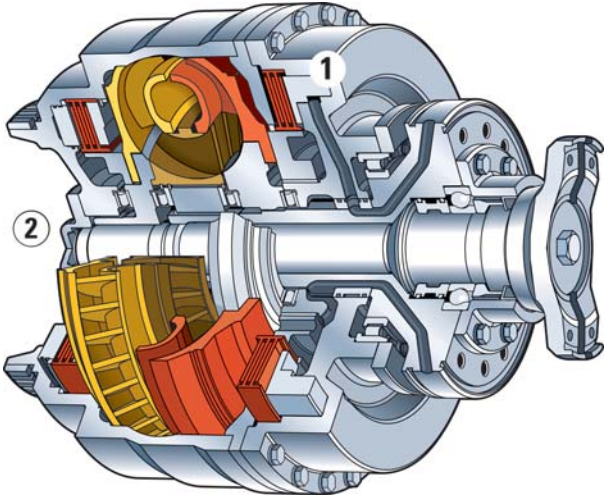

Load Sense Steering System

Typical steering systems can draw more than 30 kW (40 hp) from the engine. The draw is constant, even when the operator is not steering. This system maximizes performance by directing power through the steering system only when it's needed. More efficient use of power results in decreased fuel consumption and higher production.

Torque Converter Lock Up Clutch

The torque converter lock up clutch provides direct drive for improved fuel economy, especially in load and carry operations. This feature activates in second and third gears forward and first through third gears reverse.

Demand Driven Cooling Fan

A variable displacement pump drives the fans hydraulic motor so that fan speed varies independent of engine speed. The pump increases output as temperatures increase, improving cooling capability. The fan draws only the power needed for cooling, reducing fuel consumption and increasing efficiency.

Engine Idle Shutdown

This new feature will automatically shutdown the engine after the machine has been in a safe idling state for an extended amount of time. The operator in the cab will be audibly and visually warned before the shutdown occurs.

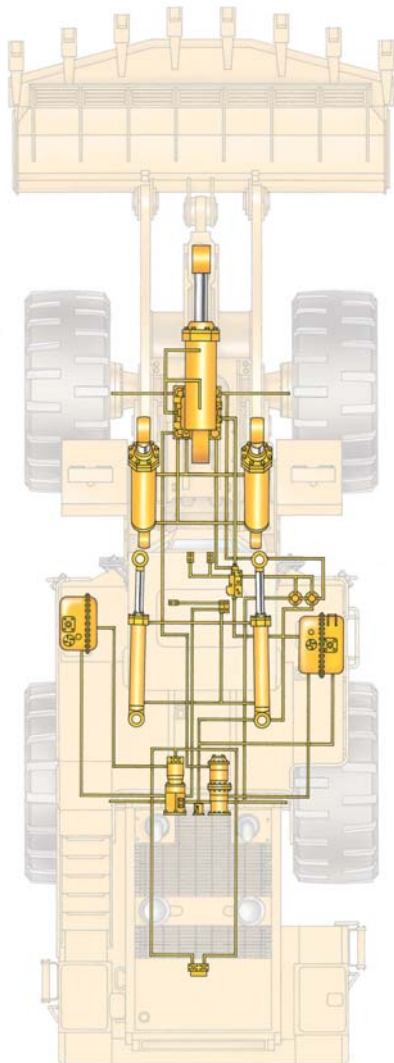

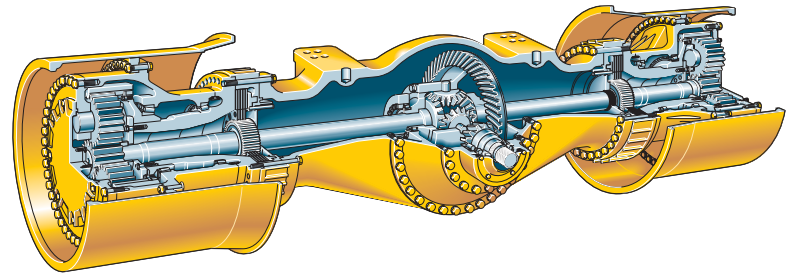
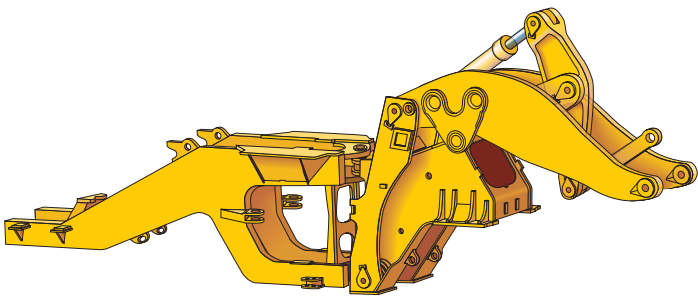

Reliability

Maximize uptime, long life – it's what you expect from your Cat[®] wheel loader

Structures

Combining the use of robotic welding and castings in critical high-stress areas, more than 80 percent of the 990H structure is robotically-welded to provide highly consistent welds and increased strength. Castings are also used in several areas to increase strength by helping to spread the loads and reduce the number of parts.

Front Frame and Rear Frame

Highly engineered and field-proven, the 990H uses high-strength plates and castings which distribute loads and increases structure robustness. A key differentiator from other manufacturers' machines is the box-section rear frame and box-shaped loader tower. The box section absorbs torsional forces generated in a loading cycle, maintaining alignment for hitch pins and driveline. The box-shaped loader tower resists shock and torsional loads, maintaining hitch and loader linkage pin alignment, maximizing pin life.

Axle-Shaft, Oil Disc Brakes

These brakes are adjustment-free, fully hydraulic and completely sealed. Disc face grooves provide cooling even when brakes are applied for a longer component life.

- Location of the brakes allows for improved serviceability. The axle shaft brake design allows for brake service while leaving the final drive intact.
- Axle-shaft brakes require less force by operating on the low torque side of the axle. Combined with improved axle oil circulation for increased cooling, the oil-enclosed, multiple disc brake design improves durability.

Z-bar Loader Linkage

Proven Z-bar loader linkage geometry delivers maximum productivity. Fewer pivot points and moving parts are designed to reduce maintenance costs.

Operator Comfort

Best-in-class working environment



Best-in-Class Working Environment

A comfortable operator is a productive operator, which is why Caterpillar has designed the 990H with a best in-class working environment for this size wheel loader class.

- World class cab incorporates features for operator comfort and ergonomics, visibility and ease of operation.
- Ergonomic controls are fully adjustable and designed for low-effort comfort. Switches and controls for various systems are located within easy reach of the operator.
- Interior noise levels are reduced to a quiet 72 dB(A).
- Cat Monitoring System (EMS-III) provides information on machine's major components. This includes gauge displays for the fuel tank level; temperature gauges for the engine coolant, torque converter and hydraulic oil; tachometer analog gauge with digital readout for gear selection and ground speed and a monitoring system.
- Optional features are available for improved visibility. These options include a rear vision camera to clearly monitor movement behind the wheel loader and high intensity discharge (HID) lights for greater visibility at night.
- Standard trainers seat allows for a safe method to properly train your operator.



Technology Solutions

Systems and features to achieve even greater productivity

Payload Control System

Payload Control System (PCS) is designed to help the 990H owners and operators manage truck payloads and produce accurate records of material movement. This advanced electronic control system is designed for on-the-go weighing.

Cat Product Link

Cat® Product Link enables convenient, remote monitoring of equipment. It provides usable information to keep jobs on schedule, maintain machine health and reduce fleet owning and operating costs.

- Simplify fleet management and monitor machine use
- Link all machines, regardless of brand
- Three levels of insight to meet specific business requirements

Cat Detect

Using a combination of radars, an in-cab display, and multiple cameras, Cat Detect provides equipment operators with enhanced awareness for increased site safety.

The touch screen display alerts the operator when objects have entered critical areas around the equipment. The radar view provides a visual indication of where the objects are relative to the machine.

Buckets and Ground Engaging Tools

Provide flexibility to match the machine to your application

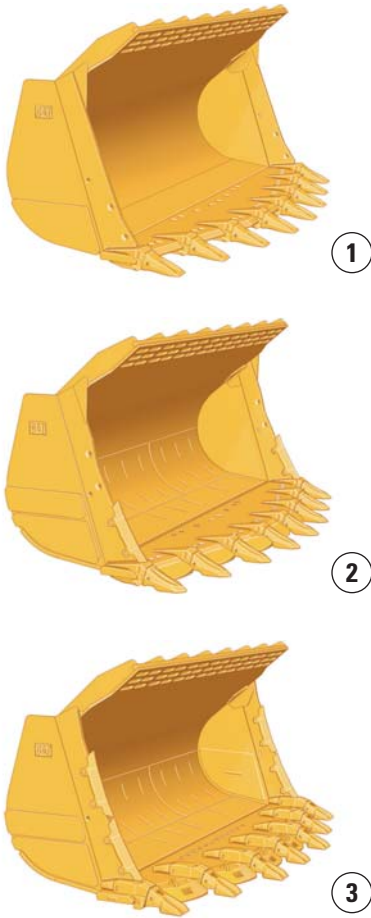

Buckets

Buckets for the 990H range in size from 8.6 m³ (11.25 yd³) to 9.2 m³ (12 yd³) and may be configured for a variety of impact and abrasive conditions.

All buckets are built with shell-tine construction that resists twisting and distortion and feature replaceable, weld-on wear plates to protect the bottom of the bucket. The integral rock guard helps retain big loads while heavy-duty pins and retainers provide durability.

Rock Buckets

Available in spade edge or straight edge configurations. Spade edge buckets use bolt-on segments and are available from 8.6 m³ (11.25 yd³) to 9.2 m³ (12 yd³). An 8.6 m³ (11.25 yd³) Straight Edge Rock is also available. Each bucket accepts up to two sets of sidebar protectors, features double-strap adapters, easily changed bolt-on segments and several tip options.

Heavy-Duty Quarry Bucket

Available as an 8.6 m³ (11.25 yd³) capacity bucket and is recommended for use in face loading where moderate abrasion and high impact is encountered. It features additional wear protection items, including: thicker base edge and adapters, additional liners and wear plates, bolt-on half arrow segments and four sidebar protectors.

High Abrasion Bucket

Available as an 8.6 m³ (11.25 yd³) capacity bucket and is recommended for use in face loading where high abrasion and moderate impact is encountered. This bucket features additional wear protection items including independently attached edge and adapter covers, flush mount adapters, additional liners and wear plates, four sidebar protectors (two sets) and a thicker base edge. Flush mount adapters provide a smooth finish floor and reduce wear on the adapters.

Material Density				Bucket Volume	
kg/m ³	tonnes/m ³	lb/yd ³	tons/yd ³	m ³	yd ³
1483-1614	1.47-1.61	2,500-2,750	1.25-1.38	9.2	12
1638-1801	1.64-1.80	2,700-3,000	1.39-1.50	8.6	11.25



Serviceability

Increase uptime by reducing service time

The 990H is designed to ensure minimal downtime through ground level or platform access, grouped service points, and attention to key serviceable areas on the machine.

- Maintain three points of contact at all times through ground level or platform accessible service areas.
- Ground level viewable site gauges on all major systems.
- Ground level engine shutdown, battery disconnect switch and steering hitch lock lever allow service technicians to perform maintenance while the machine stays static.
- Longer service intervals on fluids and filters.
- Swing-out doors on both sides of the engine compartment provide easy access to the engine oil dipstick and filler spout, S·O·SSM ports, fuel filters, air conditioner compressor, engine oil filters, alternator, starting receptacle, air filter service indicator, cooler fill and ether starting aid.
- Maintenance-free batteries
- Ecology drains for ease of service and prevention of spilling potential environmental contaminants. Ecology drains are standard on the hydraulic, engine, transmission and coolant systems.



Customer Support

Count on Cat dealers for business solutions

Selection

Cat dealers can help customers compare and choose the right machine for their business.

Financing

Cat dealers offer financing options to meet a variety of needs.

Operation

Improve operating technique for better productivity and profit with the latest Cat dealer training resources.

Product Support

Cat dealers are with customers every step of the way with unsurpassed worldwide parts support, trained technicians and customer support agreements.



Sustainability

Protecting the environment

Protecting the Environment

With the 990H having a long legacy, it is only fitting this machine has features and services that show environmental responsibility.

- First in this wheel loader size class to meet Tier 3 emissions, and Caterpillar continues to develop technology to meet changing regulatory requirements.
- Maintenance-free, ease of maintenance or extended maintenance, attention has been paid to lowering routine maintenance cost while eliminating waste to the environment.
- Caterpillar provides a number of sustainable options such as our Reman and Certified Rebuild programs. In these programs, reused or remanufactured components can deliver cost savings of 40 to 70 percent, which lowers operating cost while benefiting the environment.
- Caterpillar offers retrofit packages to bring new features to older machines, maximizing your resource. And, when you go through the Cat Certified Rebuild program, these retrofit kits are part of the rebuild process.

Safety

Keeping your people safe and productive is our number one priority

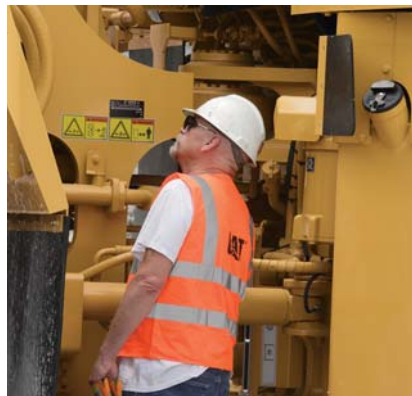

At Caterpillar, we have designed the 990H with your most important asset in mind – People. Drawing from a history of technological advancements and practical wisdom, you can be assured that your people are protected while working in, on or around the 990H Wheel Loader.

Visibility

Whether it be positioning to the truck or watching for people and vehicles on the site, the 990H offers a number of standard and optional features to enhance job site visibility.

Features include:

- Articulated wiper/washer system with intermittent features
- Optional high intensity discharge (HID) lights
- Optional warning beacons
- Optional rear vision camera

Access and Egress

The 990H has a number of features to ensure your operator gets safely on and off the 990H.

- Primary and secondary stairwell exits
- Punch stamped tread plates
- Ground level night time stairwell lights
- Full perimeter railings and toe kicks on upper platform
- Side platform emergency egress
- Optional roading fenders

Maintenance Safety

With the 990H, design efforts were taken to group service points with convenient access. As seen in the serviceability section, all service points are at ground level or platform access to maintain three points of contact, and a number of disconnect switches are available to ensure the 990H is static during service.

Operator Health and Well Being

The 990H offers many features that enhance operator comfort and aid in keeping the operator safe.

- Ergonomic cab controls designed for easy adjustment, low effort and minimal motion
- Cab air filtration system
- Laminated cab glass to minimize sound levels
- Optional secondary steering

990H Wheel Loader Specifications

Engine

Engine Model	Cat® C27 ACERT®	
Gross Power	512 kW	687 hp
Net Power	468 kW	627 hp
Net Power – ISO 14396	499 kW	669 hp
Net Power – EEC 80/1269	468 kW	627 hp
Net Power – ISO 9249	468 kW	627 hp
Net Power – SAE J1349	463 kW	621 hp
Net Power – DIN 70020	650 PS	
Bore	137 mm	5.4 in
Stroke	152 mm	6 in
Displacement	27.1 L	1,666 in ³

- These ratings apply at 2,000 rpm when tested under the specified standard conditions for the specified standard.
- Power rating conditions are based on standard air conditions of 25° C (77° F) and 99 kPa (29.32 in Hg) dry barometer, used 35° API gravity fuel having an LHV of 42 780 kJ/kg (18,390 Btu/lb) when used at 30° C (86° F) [ref. a fuel density of 838.9 g/L (7.001 lb/gal)].
- Net power advertised is the power available at the flywheel when the engine is equipped with fan, air cleaner, muffler and alternator.
- No derating required up to 3300 m (11,000 ft) altitude.

Operating Specifications

Rated Payload	15 tonnes	16.5 tons
Operating Weight	77 842 kg	171,642 lb

Transmission

Transmission Type	Powershift	
Forward 1	7 km/h	4.35 mph
Forward 2	12.8 km/h	7.95 mph
Forward 3	22.4 km/h	13.92 mph
Reverse 1	7.9 km/h	4.91 mph
Reverse 2	14.1 km/h	8.76 mph
Reverse 3	24.8 km/h	15.41 mph
Converter Drive – Forward 1	7 km/h	4.3 mph
Converter Drive – Forward 2	12.1 km/h	7.5 mph
Converter Drive – Forward 3	20.8 km/h	12.9 mph
Converter Drive – Reverse 1	7.7 km/h	4.8 mph
Converter Drive – Reverse 2	13.4 km/h	8.3 mph
Converter Drive – Reverse 3	22.8 km/h	14.2 mph
Direct Drive – Forward 1	Lock-up disabled	
Direct Drive – Forward 2	12.8 km/h	7.9 mph
Direct Drive – Forward 3	22.4 km/h	13.9 mph
Direct Drive – Reverse 1	7.9 km/h	4.9 mph
Direct Drive – Reverse 2	14.1 km/h	8.8 mph
Direct Drive – Reverse 3	24.8 km/h	15.4 mph

Hydraulic Cycle Time

Raise	9.2 Seconds
Dump	2.9 Seconds
Lower Float Down (Empty)	3.8 Seconds
Total Hydraulic Cycle Time	15.9 Seconds

Service Refill Capacities

Fuel Tank	1074 L	284 gal
Cooling System	190 L	50.2 gal
Crankcase	95 L	25 gal
Transmission	110 L	29 gal
Differentials and Final Drives – Front	271 L	71.6 gal
Differentials and Final Drives – Rear	261 L	68.9 gal
Hydraulic System (tank only)	174 L	45.97 gal
Hydraulic System – Lift/Tilt and Brakes	435 L	113 gal
Hydraulic System – Steering and Engine Cooling Fan	194 L	50.5 gal
Hydraulic System (including tank)	435 L	114.91 gal

990H Wheel Loader Specifications

Buckets

Bucket Capacities 8.4-9.2 m³ (11-12 yd³)

Axles

Maximum Single-Wheel Rise and Fall 572 mm 22.5 in

Front Fixed

Rear Oscillating

Oscillation Angle ±11°

Brakes

Brakes Meet SAE/ISO 3450 1996

Cab

Cab – ROPS/FOPS Meets SAE and ISO standards

- Cat cab Rollover Protective Structure (ROPS/FOPS) are standard.
- Standard air conditioning system contains environmentally friendly R134a refrigerant.
- ROPS meets SAE J1040 APR88 and ISO 3471:1994 criteria.
- FOPS meets SAE J231 JAN81 and ISO 3449:1992 Level II criteria.

Sound Performance Sound Performance Meets ANSI, SAE and ISO standards

- The operator sound exposure Leq (equivalent sound pressure level) measured according to the work cycle procedures specified in ANSI/SAE J1166 OCT98 is 72 dB(A), for the cab offered by Caterpillar, when properly installed, maintained and tested with the doors and windows closed.
- Hearing protection may be needed when operating with an open operator station and cab (when not properly maintained or doors/windows open) for extended periods or in noisy environment.
- The exterior sound pressure level for the standard machine measured at a distance of 15 m (49.2 ft) according to the test procedures specified in SAE J88 JUN86 mid-gear-moving operation is 82 dB(A).
- The machine sound power level is 114 dB(A), measured according to the test procedures and conditions specified in ISO 6395:2008 for a standard machine configuration. The measurement was conducted at 70% of the maximum engine cooling fan speed.
- The machine sound power level is 111 dB(A), measured according to the test procedures and conditions specified in ISO 6395:2008 for a sound suppression machine configuration. The measurement was conducted at 70% of the maximum engine cooling fan speed.
- The operator sound pressure level is 72 dB(A), measured according to the test procedures and conditions specified in ISO 6396:2008 for a sound suppression machine configuration. The measurement was conducted at 70% of the maximum engine cooling fan speed.

Steering

Minimum Turning Radius (over bucket) 10 337 mm 407 in

Steering Angle, each direction 35°

Hydraulic Output at 2,128 rpm and 6900 kPa (1,000 psi) 410 L/min 108 gal/min

Relief Valve Setting 31 000 kPa 4,500 psi

Minimum Turning Radius (over bucket) – HL 10 757 mm 424 in

Tires

Tires Tires used for measurement – 41.25/70-39 42 ply

- 41.25/70-39 42PR L5 General
- 41.25/70-39 42 PR L5 Firestone
- 45/65 R39 L5 VSDL Bridgestone*
- 45/65 R39 XLDD2 L5 Michelin*
- Note: In certain applications (such as load and carry), the loader's productive capabilities might exceed the tires' tonnes-km/h (ton-mph) capabilities. Caterpillar recommends that you consult a tire supplier to evaluate all conditions before selecting a tire model. Other special tires are available on request.

Loader Hydraulic System

Main Hydraulic System Output at 2,128 rpm and 6900 kPa (1,000 psi) 650 L/min 172 gal/min

Relief Valve Setting 31 000 kPa 4,500 psi

Cylinders, Double Acting: Lift, Bore and Stroke 234 mm × 1270 mm 9.25 in × 50 in

Cylinder, Double Acting: Tilt, Bore and Stroke 292 mm × 820 mm 11.5 in × 32.3 in

Pilot System, Gear-Type Pump Output at 2,000 rpm and 6900 kPa (1,000 psi) 46 L/min 12 gal/min

Relief Valve Setting (low idle) 2400 kPa 350 psi

Operation Specifications: Standard Lift

		990H STD Tires: 45/65R39 XLDD2 Part No. SLR:1203 mm				
Bucket Type		Rock	Rock	Rock	Rock	
Ground Engaging Tools		Teeth & Segments	Teeth & Segments	Teeth & Segments	Teeth & Segments	
Cutting Edge Type		Spade	Spade	Spade	Spade	
Bucket Part No. (Group Level)		255-3757	255-3754	310-9100	283-1880	
Bucket Load at Rated Capacity	kg lb	15 000 33,070	15 000 33,070	15 000 33,070	15 000 33,070	
Heaped Capacity ISO	m ³ yd ³	8.5 11.1	9.0 11.8	8.5 11.1	8.5 11.1	
Struck Capacity ISO	m ³ yd ³	7.0 9.2	7.5 9.9	7.0 9.2	7.0 9.2	
Bucket Width	mm ft-in	4450 14'7"	4610 15'1"	4634 15'2"	4450 14'7"	
Clearance at Full Lift, 45° Dump	SAE	mm ft-in	4227 13'10"	4171 13'8"	4270 14'0"	4226 13'10"
	Tooth Tip	mm ft-in	4026 13'2"	3973 13'0"	4012 13'2"	3976 13'1"
Reach at Full Lift, 45° Dump	SAE	mm ft-in	2024 6'8"	2080 6'10"	1981 6'6"	2025 6'8"
	Tooth Tip	mm ft-in	2211 7'3"	2264 7'5"	2250 7'5"	2242 7'4"
Reach @ Level Arm and Level Bucket	SAE	mm ft-in	3951 13'0"	4031 13'3"	3891 12'9"	3953 13'0"
	Tooth Tip	mm ft-in	4226 13'10"	4301 14'1"	4263 14'0"	4283 14'1"
Digging Depth	mm ft-in	113 4"	113 4"	113 4"	113 4"	
Overall Length	mm ft-in	12 787 41'11"	12 862 42'2"	12 824 42'1"	12 844 42'2"	
Overall Height	mm ft-in	8127 26'8"	8127 26'8"	8127 26'8"	8127 26'8"	
Clearance Circle @ Carry	Tooth Tip	mm ft-in	20 675 67'10"	20 849 68'5"	20 808 68'3"	20 731 68'0"
Tipping Load	Straight	kg lb	46 827 103,236	46 296 102,064	44 640 98,415	45 836 101,050
	At Operating Weight Art 35°	kg lb	41 855 92,275	41 344 91,147	39 685 87,491	40 861 90,083
Breakout Force	kN lb	594.0 133,546	568.5 127,814	603.7 135,706	591.0 132,861	
Operating Weight*	kg lb	78 370 172,777	78 655 173,405	80 204 176,820	79 378 174,999	

* Static tipping load and operating weight are based on standard machine configuration with 41.25/70-39 42 PR (L-5) tires, full fuel lubricants and operator.

990H Wheel Loader Specifications

Operation Specifications: High Lift

		990H HL Tires: 45/65R39 XLDD2 Part No. SLR:1203 mm			
Bucket Type		Rock	Rock	Rock	
Ground Engaging Tools		Teeth & Segments	Teeth & Segments	Teeth & Segments	
Cutting Edge Type		Spade	Spade	Spade	
Bucket Part No. (Group Level)		255-3757	310-9100	283-1880	
Bucket Load at Rated Capacity	kg lb	15 000 33,070	15 000 33,070	15 000 33,070	
Heaped Capacity ISO	m ³ yd ³	8.5 11.1	8.5 11.1	8.5 11.1	
Struck Capacity ISO	m ³ yd ³	7.0 9.2	7.0 9.2	7.0 9.2	
Bucket Width	mm ft-in	4450 14'7"	4634 15'2"	4450 14'7"	
Clearance at Full Lift, 45° Dump	SAE	mm ft-in	4793 15'9"	4835 15'10"	4792 15'9"
	Tooth Tip	mm ft-in	4591 15'1"	4578 15'0"	4542 14'11"
Reach at Full Lift, 45° Dump	SAE	mm ft-in	2318 7'7"	2275 7'6"	2319 7'7"
	Tooth Tip	mm ft-in	2505 8'3"	2544 8'4"	2536 8'4"
Reach @ Level Arm and Level Bucket	SAE	mm ft-in	4551 14'11"	4491 14'9"	4553 14'11"
	Tooth Tip	mm ft-in	4826 15'10"	4863 15'11"	4883 16'0"
Digging Depth	mm ft-in	155 6"	155 6"	155 6"	
Overall Length	mm ft-in	13 526 44'5"	13 563 44'6"	13 583 44'7"	
Overall Height	mm ft-in	8693 28'6"	8693 28'6"	8693 28'6"	
Clearance Circle @ Carry	Tooth Tip	mm ft-in	21 328 70'0"	21 473 70'5"	21 389 70'2"
Tipping Load	Straight	kg lb	43 178 95,190	40 984 90,354	42 031 92,663
	At Operating Weight Art 35°	kg lb	38 239 84,303	36 061 79,501	37 091 81,771
Breakout Force	kN lb	559.9 125,869	568.4 127,787	556.9 125,192	
Operating Weight*	kg lb	82 467 181,808	84 301 185,851	83 475 184,030	

* Static tipping load and operating weight are based on standard machine configuration with 41.25/70-39 42 PR (L-5) tires, full fuel lubricants and operator.

Dimensions

All dimensions are approximate.

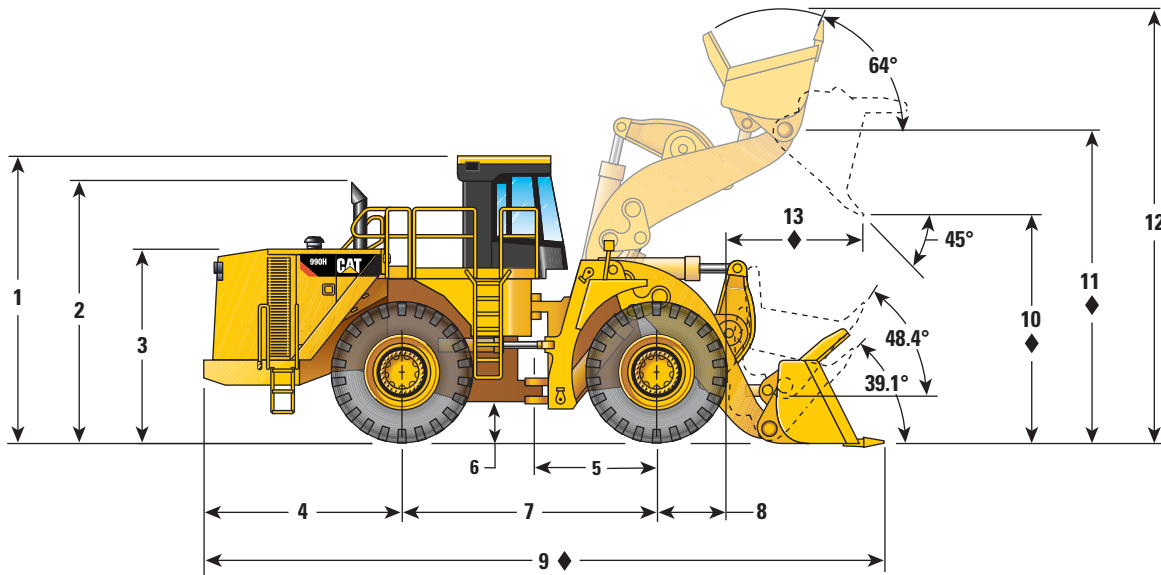

1 Height to Top of ROPS/FOPS	5070 mm	16 ft 8 in
2 Height to Top of Exhaust Stacks	4726 mm	15 ft 6 in
3 Height to Top of Hood	3515 mm	11 ft 6 in
4 Center Line of Rear Axle to Edge of Rear Bumper	3615 mm	11 ft 10 in
5 Center Line of Front Axle to Hitch	2300 mm	7 ft 7 in
6 Ground Clearance	478 mm	1 ft 7 in
7 Wheel Base Length	4600 mm	15 ft 1 in
8 Center Line Front Axle to Front of Front Tires	1289 mm	4 ft 3 in
9 Overall Length – Standard Lift	12 787 mm	41 ft 11 in
Overall Length – High Lift	13 526 mm	44 ft 5 in
10 Clearance at Maximum Lift/Dump – Standard Lift	4026 mm	13 ft 2 in
Clearance at Maximum Lift/Dump – High Lift	4591 mm	15 ft 1 in
11 B-Pin Height at Full Lift – Standard Lift	5921 mm	19 ft 5 in
B-Pin Height at Full Lift – High Lift	6487 mm	21 ft 4 in
12 Overall Height with Bucket Raised – Standard Lift	8127 mm	26 ft 8 in
Overall Height with Bucket Raised – High Lift	8693 mm	28 ft 6 in
13 Reach at Maximum Lift/Dump – Standard Lift	2211 mm	7 ft 3 in
Reach at Maximum Lift/Dump – High Lift	2505 mm	8 ft 3 in
Turning Circle – Standard Lift	20 675 mm	67 ft 10 in
Turning Circle – High Lift	21 328 mm	70 ft
Straight Static Tipping Load – Standard Lift	46 827 kg	103,236 lb
Straight Static Tipping Load – High Lift	44 152 kg	97,338 lb
Width Over Tires	4071 mm	13 ft 4 in
Full Turn Static Tipping Load at 35° – standard lift	41 855 kg	92,275 lb
Tread Width	3050 mm	10 ft

990H dimensions based on 8.5 m³ (11.1 yd³) bucket with teeth and segments.

◆ Dimensions vary with bucket. Refer to operating specifications charts.

990H Standard Equipment

Standard equipment may vary. Consult your Cat dealer for details.

Electrical

- Alarm, back-up
- Alternator (95-amp)
- Batteries, maintenance-free
- Deutsch terminal connectors
- Diagnostic connector starting and charging system
- Electrical system, 24-volt
- Electronic transmission control
- Lighting system, halogen
(front and rear) working, plus stop lights
- Starter, electric
- Starter receptacle for emergency start

Operator Environment

- Air conditioner
- Cab, sound-suppressed rollover protective structure (ROPS/FOPS)
 - Radio ready for (entertainment) includes antenna, speakers and converter (12-volt 5-amp)
- Cigar lighter and ashtray
- Coat hook
- Computerized monitoring system (EMS II)
 - Instrumentation, gauges:
 - Coolant temperature
 - Fuel level
 - Hydraulic oil temperature
 - Tachometer
 - Transmission oil temperature
 - Instrumentation, warning indicators:
 - Axle oil temperature (front and rear)
 - Brake oil pressure
 - Brake, parking/secondary
 - Electrical system (low voltage)
 - Engine oil pressure
 - Engine coolant flow
 - Engine overspeed
 - Secondary steering (if so equipped)
 - Steering oil temperature
 - Transmission filter status

Heater and defroster

- Horn, electric
- Indicator lights:
 - Quick-shift, throttle lock, torque converter and reduced rimpull control
- Lift and tilt function lockout
- Light, dome (cab)
- Lunchbox and beverage holders
- Mirrors, rearview (exterior mounted)
- Quick shift feature
- Seat belt, retractable, 76 mm (3 in) wide
- Seat, Cat Comfort, (cloth) air suspension
- STIC™ control system
- Tinted glass
- Wet-arm wiper/washers
(front, rear, and corner)
 - Intermittent front wiper

Power Train

- Brakes, full hydraulic, enclosed, oil-disc
 - Axle-shaft oil-disc service brake, parking/secondary brake
- Demand fan
- Engine, Cat C27 ACERT® with MEUI fuel system, ATAAC and ECM
- Fuel priming pump
- Precleaner, engine air intake
- Radiator, Next Generation Modular Separated cooling system
- Starting aid (ether) manual override
- Throttle lock
- Torque converter, impeller clutch with lock-up clutch feature and rimpull control system
- Transmission, 533 mm (21 in) planetary power shift (electronic) (3F/3R)

Other Standard Equipment

- Automatic bucket leveler
- Automatic lift kickout
- Axle temperature sensor
- Engine, crankcase, 500 hour interval with Cat approved oil
- Fenders, steel (front)
- Grouped labeled lube points
- Guards, crankcase and power train
- Hood, tapered
- Hitch, drawbar with pin
- Mufflers (under hood)
- Oil sampling valves
- Sight gauges for steering/fan and implement/brake
- Stairway, left side rear access
- Steering, load sensing
- Step for front windshield cleaning
- Vandalism protection caplocks
- Venturi stack

Tires, Rims and Wheels

A tire must be selected from the mandatory attachments section. Base machine price includes a tire allowance.

Antifreeze

Premixed 50% concentration of extended life coolant with freeze protection to -34° C (-29° F)

Optional equipment may vary. Consult your Cat dealer for details.

Buckets

Bucket attachments:

- Bucket teeth, long (set of 8)
- Bucket teeth, short (set of 8)
- Bucket teeth, HD long (set of 8)
- Side bar protectors (set of 2)

Camera, Rear Vision

Filtration, Case Drain

Fuel system – Fast Fill meets EUI Pressure

Vessel Requirements

High Ambient Cooling Arrangement

High Lift Arrangement

Lights

Engine Compartment

HID

Warning Beacon

Oil change system

Auto Lube

Payload Control System II

Precleaner, Cab

Ride Control System

Sound Suppression/Spectator

Stairway

Left/Right with Rooding Fenders

Right Hand

Starting aids

Cold weather starting system

Diesel fuel heater

Heater, engine coolant

Supplemental steering

Tires

990H Wheel Loader

For more complete information on Cat products, dealer services, and industry solutions, visit us on the web at www.cat.com

© 2012 Caterpillar Inc.
All rights reserved

Materials and specifications are subject to change without notice. Featured machines in photos may include additional equipment. See your Cat dealer for available options.

CAT, CATERPILLAR, SAFETY.CAT.COM, their respective logos, "Caterpillar Yellow" and the "Power Edge" trade dress, as well as corporate and product identity used herein, are trademarks of Caterpillar and may not be used without permission.

AEHQ6698 (05-2012)

