

844H

Wheel Dozer



Engine

Engine Model	Cat [®] C27 ACERT [™]	
Gross Power	512 kW	687 hp
Net Power	468 kW	627 hp

Operating Specifications

Blade Capacities	15.9-30.7 m ³	20.7-40.2 yd ³
------------------	--------------------------	---------------------------

Weights

Operating Weight	70 815 kg	156,120 lb
------------------	-----------	------------

844H Wheel Dozer

A strong power train combined with a heavy-duty front frame provides long life and economical operation.

Power Train

- ✓ The Cat® C27 ACERT™ engine is U.S. EPA Tier 3/EU Stage IIIa compliant and combined with MEUI, ADEM™ IV, axle-shaft brakes and impeller clutch torque converter with lock-up clutch provides smooth consistent shifting with rimpull control and direct drive efficiency. **pg. 4**

Cooling System

- ✓ The Next Generation Modular Radiator with Air-to-Air Aftercooling System has been added to the 844H to help meet emissions requirements and improve efficiency, serviceability and sound levels. **pg. 6**

Structures

The 844H features a box-section rear frame and four-plate front frame providing strength and stability. Together they provide resistance to dozing shocks and stresses while absorbing shock loads and twisting forces. **pg. 7**

Serviceability

- ✓ Large engine doors, rear access stairs and convenient service platform with large doors enhance serviceability on the 844H. Hydraulic, transmission and radiator sight gauges make daily checks quick and easy. **pg. 12**

Complete Customer Support

The Caterpillar® dealer network provides world class customer support and offers a wide range of services that help you operate longer with lower costs. **pg. 13**

Engineered for demanding work in large dozing applications, the Cat 844H Wheel Dozer is an ideal match for power generating utilities, clean up, road maintenance and production dozing at mines.



Hydraulics

Two, independent hydraulic systems and load-sensing steering are the invisible force behind the mobility and versatility of the 844H. **pg. 8**

Blades and Blade Controls

✓ Choose between semi-U, heavy-duty semi-U and coal blades. Replaceable bolt-on cutting edges and bottom wear plates help extend blade life. A new ergonomic, pilot controlled joystick is used to hydraulically control all blade operations. **pg. 9**

Operator Station

✓ Experience high level efficiency, productivity and comfort with the state-of-the-art cab featuring one-hand STIC™ operation, excellent ventilation, low sound levels, large viewing area and a new blade control and trainer's seat. **pg. 10**



✓ *New Feature*

Power Train

The 844H power train components deliver dependable, reliable performance customers expect from Cat Wheel Dozers.

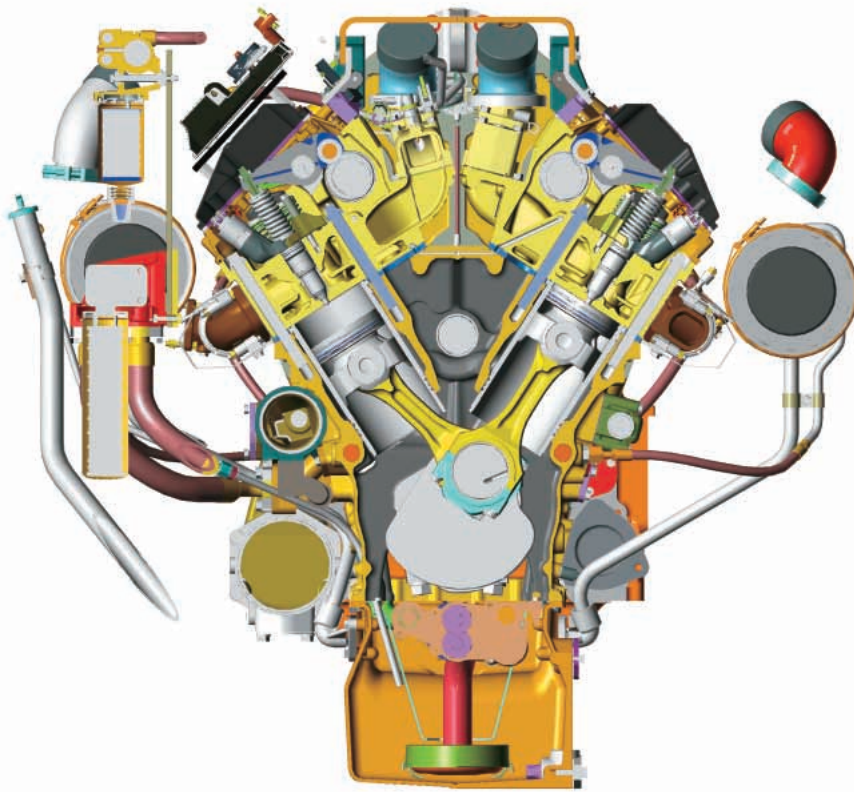

Cat C27 Engine with ACERT™ Technology.

Is rated at 468 kW (627 hp) at 2,000 rpm. The MEUI fuel system and Electronic Control Module (ECM) deliver power and efficiency in the most demanding applications. Electronic control provides many benefits:

- ADEM™ IV
- Automatic altitude deration
- Elevated low idle
- Cold weather starting mode
- Acceleration delay on startup to reduce engine wear
- Advanced diagnostic capabilities
- Automatic control of ether aid
- 500 hour oil change interval with CH-4 oil and new larger oil pan

- Dry-type air cleaner with primary and secondary elements
- Engine/torque divider module is isolation mounted to the main frame to reduce machine vibration and structure radiated noise
- Monotherm pistons

Starting System. Is direct-electric 24-volt with a 95-amp alternator and two 12-volt, 1,300 CCA, 190-amp-hour batteries.

1 Aftercooler. Lowers inlet charge temperature. Reduces thermal stresses that can cause premature wear of pistons, rings and liners.

2 High Injection Pressures. Independent of engine speed, decrease smoke and emissions while improving response.

3 Oil-Cooled Pistons and Full-Length, Water-Cooled Cylinder Liners. Provide maximum heat transfer for longer component life.

4 Engine Oil Cooler. Maintains optimum oil temperature for proper cooling and pressure lubrication. Engine cooling provided is by the NGMR. Hydrostatic fan drive gives the standard cooling package 110° F ambient capability.

Impeller Clutch Torque Converter (ICTC). Allows the operator to modulate rimpull from 100 percent to 20 percent of maximum rimpull. After 20 percent of maximum rimpull is achieved, further pedal travel applies the brake. The torque converter is equipped with a lockup clutch for direct drive efficiency.

ICTC Benefits.

- Left pedal modulation
- Compensates for wear and provides the ability to recalibrate for optimum left pedal modulation regardless of torque converter wear.

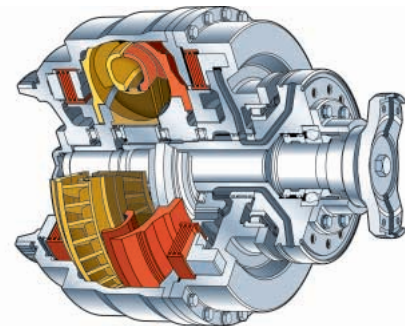

5 Impeller Clutch. Modulates the amount of engine power sent to the wheels.

6 Lockup Clutch. With Electronic Clutch Pressure Control provides direct drive efficiency in second and third forward gears and all three gears in reverse with higher speeds and improved fuel economy on long distance dozing.

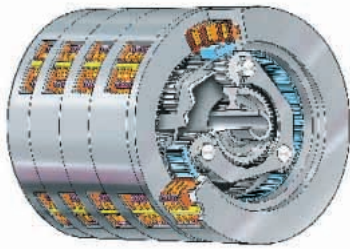

Planetary, Electronic, Power Shift Transmission. Is the same transmission found in the Cat 990H Wheel Loader. Electronic shifting provides smooth consistent shifts with fingertip controls housed in the STIC™ controller. The transmission is built around a center shaft with a gear set cluster stacked end-to-end to distribute load, conserve space and transfer energy efficiently. Large diameter perimeter clutches coupled with high contact planetary gear sets provide high torque carrying capacity for long, trouble-free life.

Parking Brake. Is spring-applied, oil-released and dry disc. It is mounted on the transmission gear output shaft. The Electronic Monitoring System III alerts the operator if the transmission is engaged while the parking brake is applied as well as if pressure drops, in which case the brake will automatically apply. Manual override is possible to allow movement of the machine.

- Self-diagnostics accessible through Caterpillar Monitoring System
- Quick Shift

7 Final Drives. Are planetary consisting of a ring gear, three planet gears, a planet gear carrier and a sun gear.

- Ring gears splined to reaction hub
- Proprietary gear cutting and heat treat methods are used in the manufacturing of components
- Full-floating bronze sleeve bearings are used on planet gears
- Oil-bath lubrication

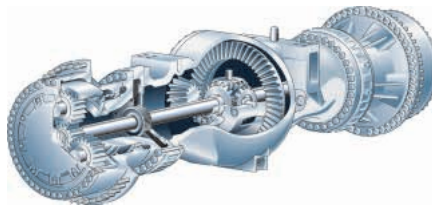

8 Axle-Shaft, Oil-Disc Brakes. Are fully hydraulic, completely sealed and never need adjustment. Disc face grooves provide cooling even when brakes are applied for a long, fade resistant life.

Design. Provides a larger cooling oil reservoir and thicker separator plates than conventional brake designs. This gives the brakes higher heat dissipation rates allowing higher capacity than conventional oil-disc brakes. Duo-cone® seals are located between the wheel and the spindle.

9 Brake Location. Reduces service time. Conventional brakes require final drive disassembly. The axle-shaft brake design allows brake service while leaving the final drive intact. Reduced service time and machine downtime keeps operating costs low.

Bevel Gear Sets and Differentials. Are common with the Cat 990H Wheel Loader.

Service Brakes. Are four wheel, hydraulic, oil-dipped multiple disc brakes that are adjustment-free, completely enclosed and allow modulated engagement without slack adjusters.

Secondary Brakes. Are fully modulated and the front and rear service brake circuits are isolated so one circuit can operate if pressure drops in the other circuit.

Cooling System

Works with the engine to meet emissions standards as well as improve serviceability and reduce downtime.

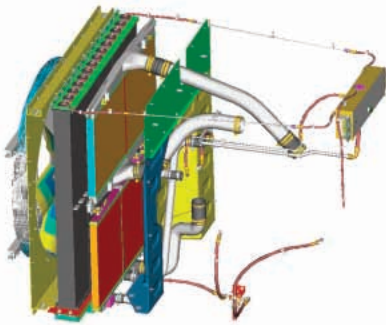

Next Generation Modular Radiator (NGMR). In order to meet U.S. EPA Tier 3 and EU Stage IIIa emissions requirements. The cooling system has been upgraded to a NGMR that utilizes the ATAAC system to achieve lower particulate, NO_x and sound output. The proven NGMR system is currently used on other Cat models such as the 834H and 988H.

NGMR is a Cat technology that improves serviceability and increases cooling efficiency by 22 percent. Ambient working temperature for the standard 844H is 43° Celsius (110° Fahrenheit). A high ambient cooling package with a 50° Celsius (122° Fahrenheit) capacity is available as an attachment.

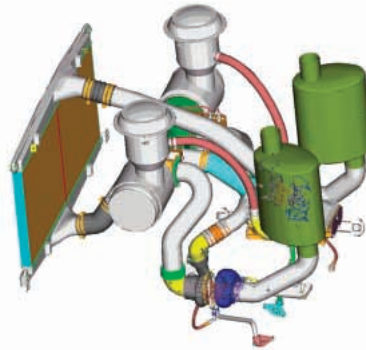

ATAAC System. Provides a separate cooling system for the intake manifold air complementing the engine jacket water cooling system. The ATAAC system routes hot, compressed air from the turbo and cools it with a single pass, air-to-air aluminum heat exchanger. The cooled compressed air is then delivered to the engine intake manifold. Providing the engine with cool compressed air greatly reduces the emissions produced, meeting Tier 3 requirements for a cleaner environment.

Separated Cooling System. Isolates the NGMR and demand fan from the engine compartment with a shield, allowing the radiator to receive outside ambient air through the side and top vents at a much lower temperature than the hot air from the engine compartment. This improves the system's efficiency and allows the radiator size to be decreased and the rear hood to be sloped, improving the rear viewing area. Also, sound levels are reduced due to the lower fan speed of a more efficient cooling system.

Serviceability. Is a key benefit. Tubes are welded to a large, thick header, providing the strength of the tube-to-header joint that reduces the possibility of coolant leaks. The NGMR core design allows removal of a single core without removing the entire radiator – reducing downtime through ease of serviceability. Replacing the individual core also reduces repair costs.

Two-Pass System. Offers increased cooling capacity. Coolant travels from the engine to the fan side of the bottom tank, up the fan side of each core, over the top, down the engine side of the core, into the engine side of the bottom tank and back to the engine. The improved flow pattern allows the coolant to pass through the radiator twice for better cooling. The NGMR design improves serviceability, reduces downtime and increases cooling capability.

Structures

Advanced design, materials and processes provide superior strength.

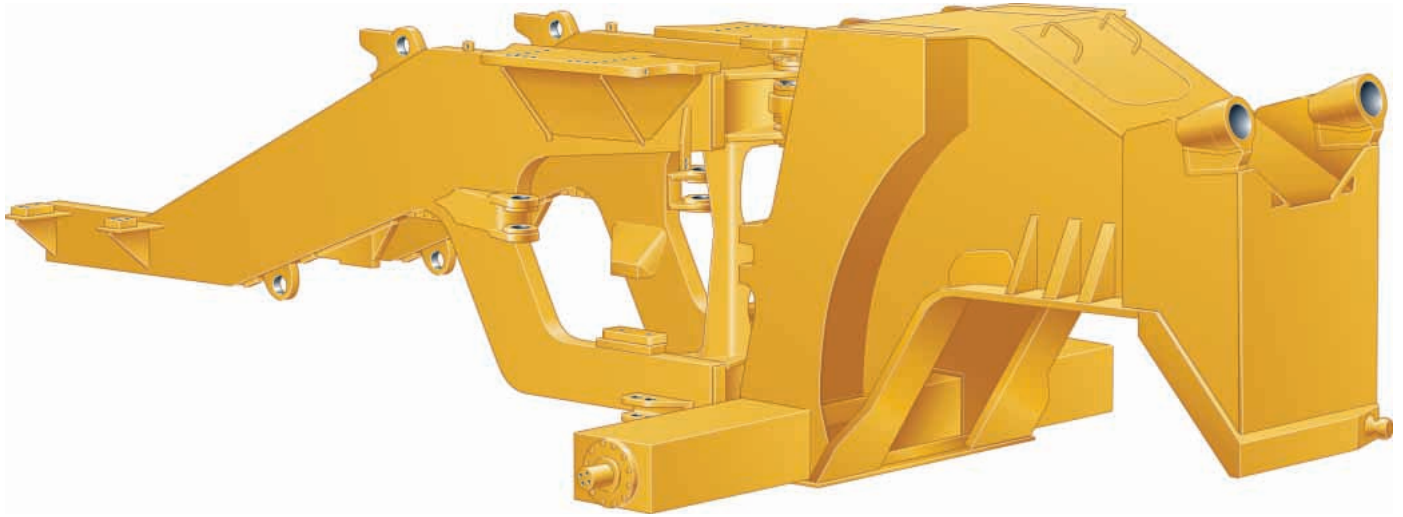

Structure Welds. Are more than 90 percent robotically welded. This provides highly consistent welds with deep plate penetration and excellent plate fusion. The benefit is greater fatigue strength and longer life than with conventional welding methods.

Castings. Are used in critical high-stress areas of the engine end frame to help spread the load and reduce the number of parts. The casting for the rear trunnion mount also serves as an engine mount, which provides a load path for the weight and torque of the engine to travel down to the trunnion and then on through to the axle. Other castings used in the engine-end frame include: front trunnion mounts, steering cylinder brackets, articulation stops and lock link.

1 Box-Section Rear Frame. Absorbs shock loads and torsional forces, solidly maintaining alignment for hitch pins and driveline.

2 Four-Plate Front Frame. Provides maximum structural strength to resist twisting loads during dozing applications.

3 Upper and Lower Hitch Pins. Pivot on double-tapered roller bearings and are shaped to direct stress away from the end of the weld, resulting in a smoother transition of stress loads.

4 Spread-Hitch Design. Helps square up the frame and provides more clearance for hydraulic lines. Double tapered roller bearings and hardened pins resist both horizontal and vertical loads to increase life. The spread hitch also makes service access easier.

Engine and Transmission Mounts. Are designed to use mushroom and cup-shaped ISO mounts, reducing component vibration and sound levels. The engine mounts directly to the rear cross member, simplifying and improving load transfer structure.

Hydraulics

Well-balanced hydraulics deliver precise, low-effort control and trouble-free operation.



1 Two Separate Hydraulic Systems.

One for lift/tilt/tip and brakes, and the other for steering and the hydraulically-driven engine cooling fan. Benefits of two systems are increased cooling and elimination of cross-contamination. If one system runs hot or is contaminated, the other will be unaffected.

2 Blade Control. Low effort, pilot joystick controls with integrated lift/tilt/tip are floor-mounted.

- Caterpillar® built tandem vane pumps provide hydraulic flow for the lift, tilt and tip functions. The circuit is well balanced to provide control when all functions are used simultaneously.
- Well-proven pumps, valves and cylinders are common with those used on Cat Large Track-Type Tractors.
- For improved serviceability, all hydraulic pumps are mounted on a single pump drive.

3 Load Sensing Steering with STIC™ Control System.

Is a revolutionary system that integrates steering and transmission into a single controller. The variable displacement pump maximizes machine performance by directing power through the steering system only when needed. More efficient use of power results in decreased fuel consumption and higher production.

- Simple side-to-side motions of the stick turn the machine right or left offering a 35 degree steering angle in both directions. Center-point frame articulation allows the front and rear wheels to track.
- Transmission shifting forward, neutral or reverse is controlled by the operator's fingers and gear selection is controlled by the operator's thumb.

XT™-3 and XT™-5 Hose. O-ring face seals and large-bore lift and tilt cylinders top off the hydraulic system, delivering the performance and durability owners expect. Reliable components reduce leaks and help protect the environment.

Hydrostatic Demand Fan. Is used for engine, transmission and hydraulic cooling. A variable displacement pump drives the fan's hydraulic motor so that fan speed varies with coolant temperature. The fan draws only the power needed for cooling, reducing fuel consumption and increasing efficiency.

Blades and Blade Controls

Cat blades are built to handle tough applications and well-proven Cat components deliver dependable service and ease of operation.

Cat Blades. Are designed with excellent dozing and rolling characteristics.

- Capacities and widths are set to achieve increased productivity
- Special design allows for spreading of cover material as well as dozing of heavier loads
- High-strength, pressed rib construction
- Cat Large Track-Type Tractor bolt-on cutting edges and bottom wear plates
- Fitted with Cat standard hardware and Ground Engaging Tools (GET)
- Rebuildable for long blade life



Coal Blade. Is designed for precise and productive dozing while helping to retain load control with increased capacity for lighter materials. Wing angles help retain the load while dozing.



Semi-U Blade. Combines the characteristics of the S and U blades into one package. Provides increased capacity with the addition of short wings which include only the dozer end bits without sacrificing spreading characteristics of straight blades.



Heavy-Duty Semi-U Blade. Has the same configuration as the Semi-U blade but is built with thicker plates for more severe applications.

Coal Scoop. Is available through Cat Work Tools.

Heavy-Duty Blade Linkage. Is common with a Cat D9 Track-Type Tractor. These well-proven components are designed for tough applications.

- Lift cylinders raise and lower blade for efficient dozing action
- Two position tilt cylinder mounting for increased flexibility for various applications

- Cutting edges are DH-2™ steel
- End bits are DH-3™ steel to provide maximum life
- Trunnions, pusharms and tag link are sized for large dozing loads

Low Effort, Pilot Operated, Joystick Blade Control. Hydraulically operates blade raise, lower, tilt and tip.

Lift Circuit. Features four positions: raise, hold, lower and float with detente hold on float.

Tilt/Tip Circuit. Offers operator selected single or dual-tilt and fingertip control for easy operation.

Operator Station

Comfort and control — a top quality operator station helps maximize productivity.



Cab Design. Is spacious and incorporates innovations for operator comfort and productivity, including an excellent viewing area, interior sound levels below 75 dB(A), Cat Comfort Series seat, standard coat hook, cup holder, storage bin, sun visor, trainer's seat with lapbelt and intermittent wet-arm wipers. It is also radio-ready for two-way radios.

1 STIC™ Control System (Steering Transmission Integrated Controller).

Is a revolutionary system that integrates steering and transmission into a single controller. Simple side-to-side motions of the operator's left arm turn the machine right or left. Transmission shifting forward, neutral or reverse is controlled by the operator's fingers, and gear selection is controlled by the operator's thumb. These factors combine to produce a fluid motion that reduces effort and allows the operator to work the machine for long periods of time with little or no fatigue.

2 Left Pedal. Operates the Impeller Clutch Torque Converter for about the first inch of travel, then engages the brakes. Within the first inch of pedal travel, rimpull can be controlled from 100 percent to 20 percent.

- By turning the Rimpull Control dial to the selected rimpull setting, the amount of power to the ground is adjusted to prevent costly tire slip.

3 Comfort Series Seat. With air suspension and retractable seat belt is designed for comfort and support. Seat cushions reduce pressure on the lower back and thighs while allowing unrestricted arm and leg movement. The seat has three height levels. The retractable seat belt remains off the floor and is easy for the operator to reach.



4 Trainer's Seat. Allows for the trainer/ rider to have a seat with lap belt.

Quick-Shift Feature. Allows quicker cycle times by shifting from first forward to second reverse.

Throttle Lock. Allows the operator to preset the engine speed and concentrate on productivity. The throttle lock can be deactivated by pressing the brake pedal.

5 Electronic Monitoring System III. Continually monitors various machine systems through three instrument clusters and provides a three-level warning system to alert the operator of immediate or pending problems. EMS III shares information with the engine, hydraulic and transmission controls that can be used during servicing to simplify service and troubleshooting.

- Gauges

Display engine coolant, transmission oil and hydraulic oil temperatures, engine oil pressure and fuel tank level.

- Tachometer/Speedometer

Display engine speed and gear indicator.

- Alert Indicators

Include charging system, parking/ secondary brake, supplemental steering, brake oil pressure, engine coolant flow and transmission filter status.

6 Floor-Mounted Hydraulic Pilot Blade Controls. Are adjustable fore and aft, with a height-adjustable armrest so operators of any size can find a comfortable operating position. A single joystick control allows operator to control blade functions: lift/lower, tip and tilt. An integrated switch allows single or dual-tilt operation.

Torque Converter Lock-up Clutch. Is activated when the operator presses a switch on the console. The 844H automatically shifts from torque converter drive to direct drive when a set speed in second and third forward or all gears in reverse is reached, providing faster travel speeds and less fuel consumption.

Large Viewing Area. Enhances viewing in all directions. Bonded glass in the front window eliminates distracting metal frames with the best operator visibility to the blade.

Serviceability

Less time spent on maintenance means more time on the job.

Easy Maintenance. In addition to the servicing features built into the engine, the 844H includes:

- **Rear Access Stairs.** For easy, comfortable access for operators and service personnel.

- **Large Engine Access Doors.**

Provide excellent access to service points, engine oil dipstick, diagnostic connector, engine oil and fuel filters, starting receptacle, air filter indicator, air filters, fuel/water separator and the ether starting aid cartridge.

- **Large Service Platform.** Provides passage to hydraulic filter, fuel fill and transmission filters through easy-to-open doors.

- **Large Door.** Provides entrance to transmission and pumps when service is required.

- **Large Platform Door.** Provides access to fuses and electronic control modules.



- **Batteries.** Are accessible through hinged doors in bumper.

- **Side Access Doors.** On the radiator guard provide easy access for radiator cleanout.

- **Grouped and Labeled Lube Points.**

Accessible at ground level, make daily lube maintenance quick and easy.



- **Sight Gauges.** In the hydraulic tanks, transmission and radiator provide quick check for fluid levels.



- **Fuses.** Automotive-style design are easy to service.

Complete Customer Support

Cat dealer services help keep machines operating longer with lower costs.

Machine Selection. Make detailed comparisons of the machines under consideration before purchase. Cat dealers can estimate component life, preventative maintenance cost and the true cost of lost production.

Purchase. Look past initial price. Consider the financing options available as well as the day-to-day operating costs. Look at dealer services that can be included in the cost of the machine to yield lower equipment owning and operating costs over the long run.

Customer Support Agreements. Cat dealers offer a variety of product support agreements and work with customers to develop a plan that best meets specific needs. These plans can cover the entire machine, including attachments, to help protect the customer's investment.

Product Support. You will find nearly all parts at our dealer parts counter. Cat dealers use a worldwide computer network to find in-stock parts to minimize machine downtime. Save money with genuine Cat Reman parts. You receive the same warranty and reliability as new products at cost savings of 40 to 70 percent.

Operation. Improving operating techniques can boost your profits. Your Cat dealer has training videotapes, literature and other ideas to help you increase productivity.



Maintenance Services. Choose from your dealer's range of maintenance services when you purchase your machine. Repair option programs guarantee the cost of repairs up front. Diagnostic programs such as S•O•SSM and Coolant Sampling and Technical Analysis help you avoid unscheduled repairs.

Replacement. Repair, rebuild or replace? Your Cat dealer can help you evaluate the cost involved so you can make the right choice.

Engine

Engine Model	Cat C27 ACERT™	
Gross Power	512 kW	687 hp
Net Power	468 kW	627 hp
Net Power – Caterpillar	468 kW	627 hp
Net Power – EEC 80/1269	468 kW	627 hp
Net Power – ISO 9249	468 kW	627 hp
Net Power – SAE J1349 (JAN90)	463 kW	621 hp
Net Power – DIN 70020	650 PS	
Bore	137 mm	5.4 in
Stroke	152 mm	6 in
Displacement	27.1 L	1,666 in ³
Cylinders	12	
Torque Rise	31%	

- These engine ratings apply at 2,000 rpm when tested under the specific standard conditions for the specified standard.
- Power rating conditions are based on standard air conditions of 25° C (77° F) and 99 kPa (29.32 in Hg) dry barometer using 35° API gravity fuel having an LHV of 42 780 kJ/kg (18,390 Btu/lb) when used at 30° C (86° F) [ref. a fuel density of 838.9 g/L (7.001 lb/gal)].
- Net power advertised is the power available at the flywheel when the engine is equipped with fan, air cleaner, muffler and alternator.
- No derating required up to 3350 m (11,000 ft) altitude.

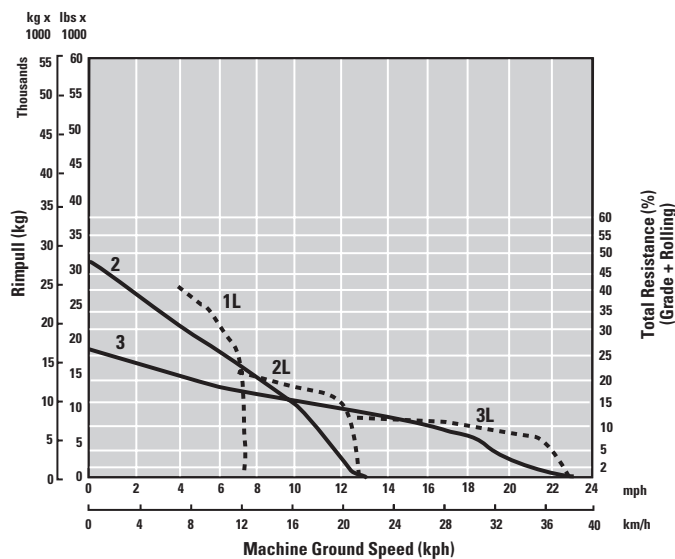

Torque Converter

Direct Drive

Weights

Operating Weight	70 815 kg	156,120 lb
------------------	-----------	------------

Transmission

Converter Drive – Forward 1	7 km/h	4.4 mph
Converter Drive – Forward 2	12.2 km/h	7.6 mph
Converter Drive – Forward 3	21 km/h	13 mph
Converter Drive – Reverse 1	7.7 km/h	4.8 mph
Converter Drive – Reverse 2	13.4 km/h	8.4 mph
Converter Drive – Reverse 3	23 km/h	14.3 mph
Direct Drive – Forward 1	7.2 km/h	4.5 mph
Direct Drive – Forward 2	12.8 km/h	7.9 mph
Direct Drive – Forward 3	22.5 km/h	14 mph
Direct Drive – Reverse 1	7.9 km/h	4.9 mph
Direct Drive – Reverse 2	14.1 km/h	8.8 mph
Direct Drive – Reverse 3	24.8 km/h	15.4 mph
Number of Forward Speeds	3	
Number of Reverse Speeds	3	

- With 45/65 R39 XLD D1 (L4) tires.
- Converter drive two percent rolling resistance.

Hydraulic System

Output at 2,040 rpm and 6900 kPa (1,000 psi)	311 L/min	82 gal/min
Cylinder, Double-Acting:	209.5 mm × 188 mm	
Tilt and Tip, Bore and Stroke	8.25 in × 7.5 in	
Relief Valve Setting – Bulldozer (Large Pump)	18 650 kPa	2,700 psi
Relief Valve Setting – Tilt Cylinders (Small Pump)	20 150 kPa	2,920 psi

- Blade control system with double-section vane pump with SAE No. 10 oil at 66° C (150° F).

Steering

Minimum Turning Radius (Over Tires)	9910 mm	390 in
Hydraulic output at 2,040 rpm and 6900 kPa (1,000 psi)	353 L/min	93 gal/min
Relief Valve Setting	34 500 kPa	5,000 psi
Steering Angle	35°	

- Full hydraulic load sensing steering system meets SAE J1511 FEB94 and ISO 5010:1992 specified standards.

Service Refill Capacities

Fuel Tank – Standard	1016 L	268.4 gal
Cooling System	150 L	39.6 gal
Crankcase	95 L	25 gal
Transmission	110 L	29 gal
Hydraulic Tank	717 L	189.4 gal
Differentials and Final Drives – Front	271 L	71.6 gal
Differentials and Final Drives – Rear	261 L	68.9 gal
Hydraulic System – Implement and Brakes (Tank Only)	197 L	52 gal
Hydraulic System – Steering and Engine Cooling Fan (Tank Only)	132 L	34.9 gal

Cab

ROPS/FOPS	Meets SAE and ISO standards
Sound Performance Levels	Meets ANSI, SAE and ISO standards

- Cat cab with integrated Rollover Protective Structure/Falling Object Protection System (ROPS/FOPS) is standard.
- Standard air conditioning system contains environmentally friendly R134a refrigerant.
- ROPS meets SAE J1040 APR88 SAE J394 and ISO 3471:1994.
- FOPS meets SAE J231 JAN81 and ISO 3449:1992 Level II criteria.
- The operator sound exposure Leq (equivalent sound pressure level) measured according to the work cycle procedures specified in ANSI/ASAE J1166 OCT98 is 72 dB(A), for the cab offered by Caterpillar, when properly installed and maintained and tested with the doors and windows closed.
- Hearing protection may be needed when operating with an open operator station and cab (when not properly maintained or doors/windows open) for extended periods or in noisy environment.
- The exterior sound pressure level for the standard machine measured at a distance of 15 m (49.2 ft) according to the test procedures specified in SAE J88 JUN86, mid-gear-moving operation, is 82 dB(A).
- The sound power level is 116 dB(A) measured according to the dynamic test procedure and conditions specified in ISO 6395:1988/Amd. 1:1996 for a standard machine configuration.
- For “CE” marked configurations, the labeled sound power level is 111 dB(A) measured according to the test procedures and conditions specified in 2000/14/EC.

Brakes

Brakes	Meets SAE/ISO 3450 1996
--------	-------------------------

Axles

Front	Fixed
Rear	Oscillating $\pm 11^\circ$
Maximum Single-Wheel Rise and Fall	572 mm 22.5 in

Tires

Tire Choices	Several choices available
Standard Tire Size	45/65 R39

- Caterpillar recommends that consulting a tire supplier to evaluate all conditions before selecting a tire model. Other special tires are available on request.
- Tubeless, low-aspect ratio. All steel radial construction for increased traction and stability, lower rolling resistance.

Operating Specifications

Blade Capacities	15.9-30.7 m ³	20.7-40.2 yd ³
Ground Clearance	475 mm	1 ft 7 in

Dimensions

All dimensions are approximate.

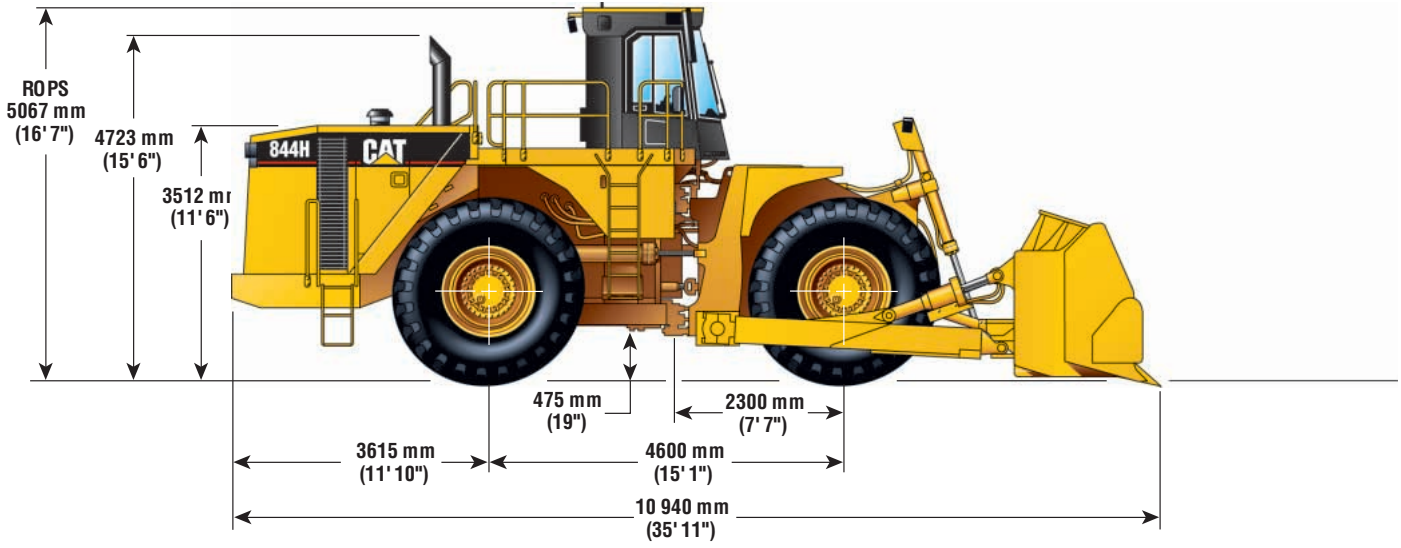

Standard Equipment

Standard equipment may vary. Consult your Caterpillar dealer for details.

Electrical

- Alternator, 95-ampere
- Converter, for 12-volt accessories
- Diagnostic connector for starting and charging systems
- Electric starter (heavy-duty)
- Electrical system, 24-volt
- External lighting system, front and rear
- Maintenance-free batteries
- Starting receptacle for emergency starting

Operator Environment

- Air conditioner, R134a refrigerant
- Cab with sound suppression
- Comfort Series Seat with air suspension
- Cigar lighter and ashtray
- Coat hook

Computerized Monitoring System

- Action alert system, three-category

Gauges:

- tachometer
- fuel level
- hydraulic oil temperature
- transmission oil temperature
- engine oil pressure
- coolant temperature

Dome light (cab)

Electric horn

External two-post ROPS structure

Heater and defroster

Integrated joystick blade control

Load-sensing steering

Quick-shift feature

Radio-ready cab for entertainment or two-way radio (three-point mounting)

Rearview mirrors

Retractable seat belt 76 mm (3 in) wide

Floor mounted hydraulic controls

Sight gauges

- Hydraulic oil, engine coolant and transmission

STIC Control Steering System

Storage for lunch box, cup

Sunshade/visor, front and rear

Throttle lock

Tinted glass

Trainer's seat with seatbelt

Transmission gear indicator

Wet-arm wiper/washers, front and rear

Power Train

Cat C27 MEUI engine with ACERT™ Technology

Air-to-Air Aftercooling System (ATAAC)

ADEM™ IV Controller

Brakes

Parking: Dry, multi-disc brake; transmission mounted,

- Service/Secondary: enclosed, wet, multi-disc brake at each wheel

Electric fuel priming aid

Impeller Clutch Torque Converter with lockup clutch

Precleaner/ejector

Remote-mounted hydraulic engine fan

Separated cooling system

Sound suppressed muffler

Supplemental steering

Transmission

533 mm (21 in) planetary power shift (electronic)

3-speed forward/3-speed reverse

Other Standard Equipment

Backup alarm

Drawbar hitch with pin

Fenders (front)

Fuel cooler

High speed oil change system

Hydraulic oil cooler

Locking engine enclosures

Power train/guard

Rear access stairs

Vandalism protection and caplocks

Venturi stacks

Tires

45/65 R39 L-4 (XLDDIA), Michelin

Contact your Cat dealer for more options.

Optional Equipment

	kg	lb
Blades		
Semi-U	7273	16,034
HD Semi-U	7763	17,114
Coal U-Blade	9542	21,036
Electrical		
Lights – Engine Compartment	2	4
HID Lights	59	130
Product Link	11	24
Radio – AM/FM Cassette	4	9
Rotating Beacon	1	2
Rear Vision Camera	12	26
Starting Aids		
Diesel Fuel Heater	9	20
Engine Coolant Heater – 120 volt	7	15
Engine Coolant Heater – 140 volt	7	15
Starting, Cold Weather	161	355

	kg	lb
Fuel System		
Fast Fuel	2	4
Access		
Left Side Stairway	430	948
Front Walkway	178	392
Roading Fenders	920	2,208
Miscellaneous		
Sound Suppression	1175	2,590
Cab Precleaner	5	11
Autolube System – Electric	0	0
Case Drain Filtration	64	141
Cooling – High Ambient	0	0
Tires		
Contact your Order Coordinator for current tire options and availability.		

844H Wheel Dozer

For more complete information on Cat products, dealer services,
and industry solutions, visit us on the web at www.cat.com

© 2005 Caterpillar
All Rights Reserved
Printed in U.S.A.

Materials and specifications are subject to change without notice.
Featured machines in photos may include additional equipment.
See your Caterpillar dealer for available options.

AEHQ5689 (11-05)

Replaces AEHQ5307-02

CAT, CATERPILLAR, ACERT, their respective logos and "Caterpillar Yellow,"
as well as corporate and product identity used herein, are trademarks of
Caterpillar and may not be used without permission.

CATERPILLAR[®]