

AJAX FLORI

TUNNEL DUMPERS

D65, D90 MAXI, D160



- One man operation
- ARAI certified - can be registered with R.T.O.
- Off-highway Rough Terrain Machine
- Rugged, yet compact
- Easy maneuverability

DIMENSIONS

D65 6.5 ton dumper

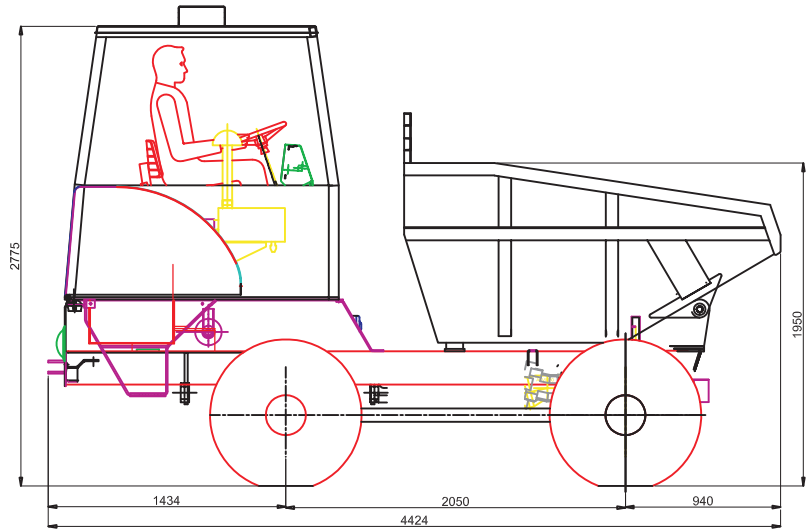
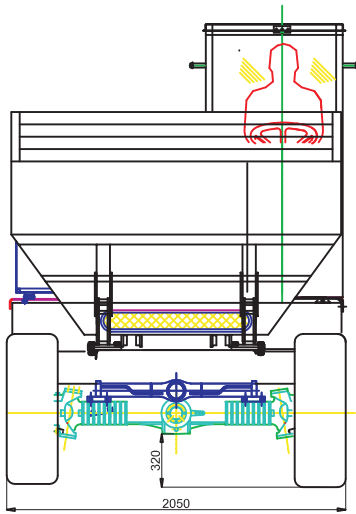

D90 maxi 12 ton dumper

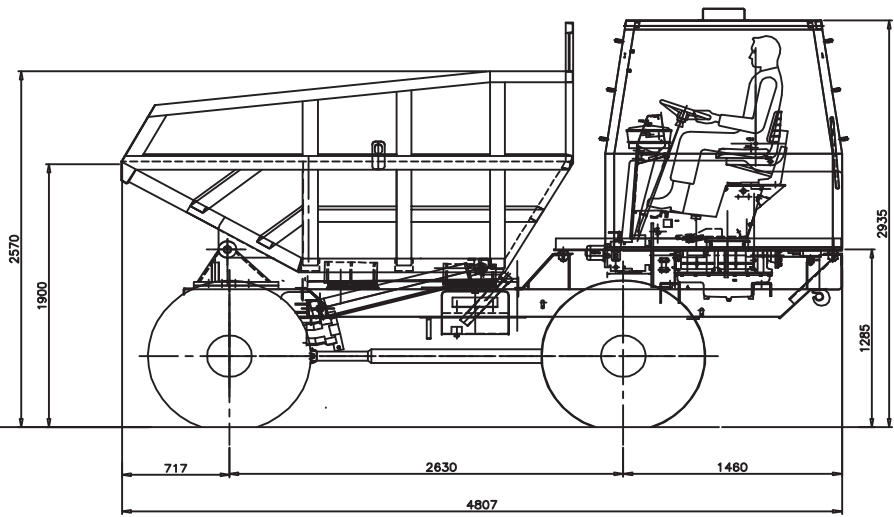
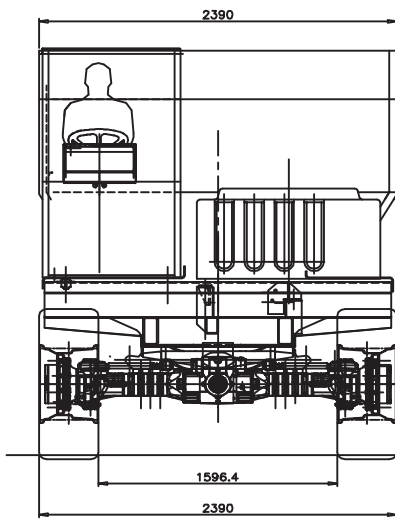

D160 16 ton dumper

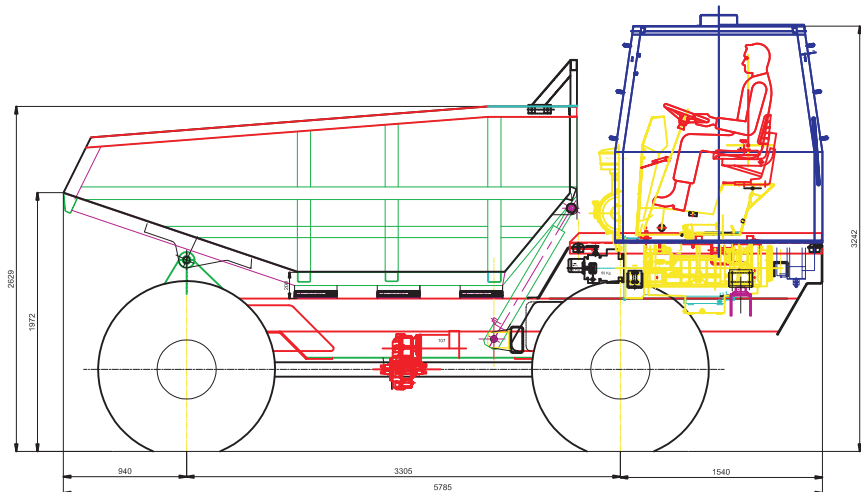
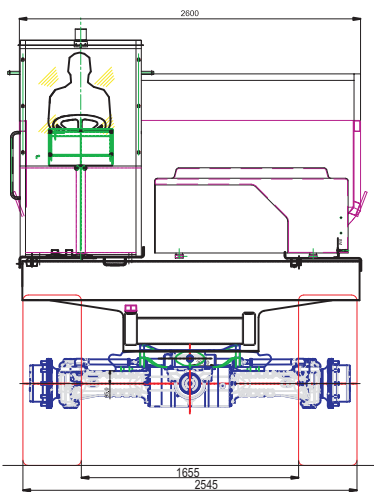

TECHNICAL SPECIFICATIONS

MODEL	D 65 (6.5 tons)	D 90 MAXI (12 tons)	D 160 (16 tons)
Engine			
Make & Model	Simpson S433	Kirloskar 4R1040T	Kirloskar 6R1080T
Maximum Power	54 hp @ 2300 rpm	110 hp @ 2500 rpm	160 hp @ 2500 rpm
Maximum Torque	187 Nm @ 1400 rpm	375 Nm @ 1500 rpm	588 Nm @ 1500 rpm
Aspiration	Natural	Turbo	Turbo
Transmission			
Type	4 wheel drive automotive hydrostatic transmission		
Control	Electro-hydraulic control for "slow" and "fast" speeds		
Speed (forward & reverse)	0 - 20 kmph	0 - 30 kmph	0 - 30 kmph
Axle			
Type	Heavy duty, fully floating type axle. Fixed rear axle & oscillating front axle		
Brake			
Type	Power braking with oil cooled disc type brakes. Dual brake circuit for front & rear axles		
Steering			
Type	Fully powered hydraulic (orbitrol type) 4 wheel steering in 3 selectable configurations		
Chassis			
Type	High tensile steel, "C" type	High tensile steel, "Box" type	High tensile steel, "Box" type
Electrical System			
Battery	12 volt, 135 amp-hr	12 volt, amp-hr	12 volt, 150 amp-hr
Alternator	12 volt, 35 amp	12 volt, 65 amp	12 volt, 65 amp
Hydraulic System			
Flow	38.34 lpm	41.68 lpm	41.68 lpm
Relief Valve Pressure Setting	160 bars	180 bars	150 bars
Skip Operation Cylinder Type	Double acting	Double acting	Telescopic
Skip			
Water Capacity	1400 litres	2900 litres	3340 litres
Struck Capacity	2800 litres	6380 litres	8550 litres
Heaped Capacity	3600 litres	7550 litres	10000 litres
Wheels			
Tyre Size	12.0/75-18-12 PR	16.0/70-20-16 PR	17.5/80-25-20 PR
Rim Syze	9 x 18	13 x 30	14 x 25
Weight			
Unladen weight	3720 kgs	5820 kgs	7800 kgs
Laden weight	10340 kgs	17820 kgs	24000 kgs
Refill Capacities			
Fuel Tank	40 litres	90 litres	136 litres
Hydraulic Tank	110 litres	110 litres	110 litres
Engine Oil	12.5 litres	11.5 litres	13 litres

AXLES :

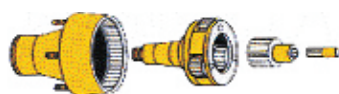

Heavy duty axles with planetary reduction

Heavy duty fully floating type axles. Fixed rear axle and floating front axle. Self bearing axle, outboard planetary reduction at wheel

SWIVELABLE OPERATOR POST ::



180 degree swivelable operator post for complete visibility during driving. Operator can face loading side during dumping operation.

STEERING

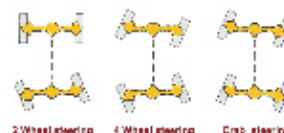

Fully powered hydraulic (orbitrol type) steering. Four wheel steering for maneuvering in narrow spaces. 3 way steering system.

APPLICATIONS



Pub No.: DUMPERS /02/Jan/11/Issue 01/1000

Specifications are subject to change without prior notice



AJAX FIORI ENGINEERING (INDIA) PRIVATE LIMITED
Joint Venture - FIORI S.p.A. Italy
148 / 25, Industrial Suburb, Yeshwanthpur, Bangalore - 560 022
Tel : 080 3921 1000, Fax : 080 2347 1757
Email : info@ajax-fiori.com, Website: www.ajax-fiori.com

For Sales Queries :

Northern Region : 096500 36628 ↑ Eastern Region : 094331 44581
Southern Region : 098450 58628 ↓ Western Region : 099672 63628

Factory: 3, 16 & 17, KIADB Industrial Area, Bashettihalli, Doddaballapur - 561 203 Tel : 080 3921 6001, Fax : 080 3921 6004