

BELAZ SERIES 7531

MEXICO, LATIN AMERICA

240mt/ 265t payload capacity



Engine

Model MTU 16V4000
Four-cycle turbocharged and intercooled direct injection diesel engine with V-type cylinders arrangement and electronic control system. Meets Tier 1 emissions requirements.

	Metric	SAE
Gross power @ 1900 rpm, kW/ hp	1865-2013	2500-2700
Maximum torque @ 1500 rpm, N.m/ ft lbs	10931-10150	8060-7485
Number of cylinders	16	16
Cylinders displacement, l/cu in	65	3967

Air cleaning is performed by three-stage filter with dry-type elements. Engine exhaust routed through body and mufflers. Circulating lubrication system is pressurized and designed with wet crankcase. Double-loop fluid cooling system with forced circulation. Oil cooling is performed by oil-to-water heat exchanger. Cooling system impeller is actuated by fluid coupling with automatic control. Cooling system activation and deactivation is thermostat controlled. Fluid preheating system. Pneumatic starter. Air pressure in starting system, MPa/ psi 0.6-0.8/ 87-116 Electric equipment system voltage, V 24

Electric Drive

Transmission is equipped with AC/AC drive with traction alternator, two traction motors, motorized wheels planetary double-row reduction units, microprocessor-based control system and control devices.

	Metric, km/h	28.38:1 SAE, mph
Transmission ratio		
Maximum speed	64	40

Traction alternator	Kato	Electrosila
Traction motor	Siemens	Electrosila
Reduction gear	Belaz	Belaz

Suspension

Suspension is conventional for front axle and drive axle, equipped with trailing arms, central joints and transverse rods. Cylinders are pneumohydraulic (nitrogen and oil) and equipped with built in hydraulic shock absorber. Two cylinders are on the front axle and two cylinders are on the rear axle.

	Metric, mm	SAE, in
Cylinder piston stroke		
- front	320	13
- rear	290	12

Steering

Hydrostatic steering with steerable front wheels.

	Metric, m	SAE, ft
Steering angle, degree	39	39
Turning radius	15	49
Overall turning diameter	34	112

The steering meets ISO 5010 requirements.

Brakes

Dump truck brake system meets ISO 3450 international safety regulations and requirements. The system is equipped with service, parking, retarding and emergency brake systems.

Service brake system

Front wheel brakes- disc type with four brake calipers per one disc. Rear wheel brakes- double-disc type with two brake caliper per each disc and automatic slack adjustment. Discs are installed on the traction electric motor shafts.

Brake drive- hydraulic, separate for the front and rear wheels.

Parking brake system- with two brake units per side, normally closed.

Brake actuation- by spring.

Brake control- hydraulic.

Retarder system- retarding by traction electric motors in generator mode with forced air cooled resistors.

Emergency brake system- parking brake system combined with operating service brake system circuit.

Grid resistors
Power, kW/ hp

17EM115
2770/ 3715

Body

Welded bucket-type body with FOPS safety system, protective canopy, engine exhaust heating, device for mechanical fixing in raised position, rock-fenders and rock-ejectors.

Body capacity:

	struck	heaped 2:1
Metric, m ³	102.4	141.1
SAE, yd ³	134	185



Frame

Frame is welded of high-strength low-alloy steel with castings at the maximum loading points with box-section variable-height side-members interconnected by cross-members.

Hydraulic Drive

Hydraulic system is combined for body dumping gear, steering and brakes actuator. The system is equipped with two-section variable-displacement axial-piston oil pump and three-stage telescopic body lifting cylinders with one stage of double action.

Body lifting time, sec	22
Body lowering time, sec	33
Maximum pressure in hydraulic system, MPa	18
Maximum pump delivery @ 1900 rpm, dm ³ /min/ gal/min	698/ 184
Filtration degree, mcm	10

Cab

Two-man two-door cab is equipped with air suspension adjustable driver seat, additional trainee seat and adjustable steering column. The cab meets EN 474-1 and EN 474-6 requirements for levels of in-cab noise, vibration, and dust.

Cab meets ROPS safety requirements.

In-cab noise level is not more than 80 dB(A).

Local vibration level is not more than 126 dB(A).

Overall vibration level is not more than 115 dB(A).

Tires

Radial tubeless air tires with quarry tread pattern.

Tire designation	40.00R57; 46/90R57
Inflation pressure, MPa/ psi	0.75; 0.7/ 109
Rim designation	32.00-57/6.0

Overall dimensions, mm*

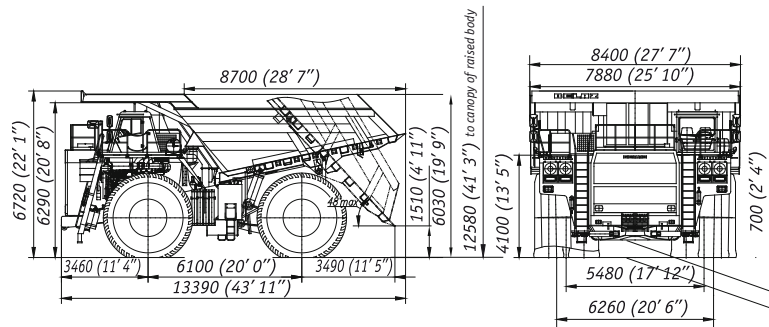

*Overall dimensions are specified for truck with standard option

Capacities

	Metric, l	SAE, gal
Fuel tank	2900	766
Engine cooling system	650	172
Engine lubrication system	265	70
Hydraulic system	790	209
Reduction gear (2)	230	61
Suspension cylinders:		
- front(2)	97.4	26
- rear (2)	103.0	61

Weight

	Metric, kg	SAE, lbs
Maximum payload capacity	240000	529110
Unladen weight	161500	356047
Gross weight	401500	1083790
Dump truck weight distribution on axles, %:		
front	unladen 45	laden 33
rear	55	67

Special equipment

- Fire-fighting system (standard)
- Starting preheater (standard)
- Heating and ventilation system (standard)
- Automatic lubrication system (optional)
- Loading and fuel control system (optional)
- Telemetering tire-pressure monitoring system (optional)
- Body floor lining (optional)
- Warning device for high-voltage line (optional)
- Diagonal stairs (optional)
- Exhaust routed undertruck (optional)

Propulsion and Retarding

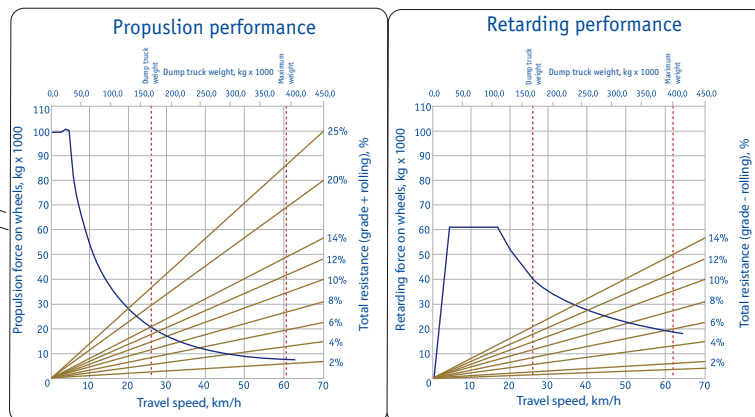

<p>OJSC "Belarusian Autoworks" (BELAZ) 40 let Oktyabrya str. 4, 222160, Zhodino, Republic of Belarus phone: +375 1775 3-60-67, 3-37-37 fax: +375 1775 7-01-37 e-mail: office@belaz.minsk.by www.belaz.by</p>	<p>Belaz Trucks Americas 6346 Orchard Lake Rd, Suite 103 West Bloomfield, MI 48322 phone: 248-539-3482 fax: 248-538-9486 e-mail: info@belaztrucks.com www.belaztrucks.com</p>
--	---