

Mine dump truck BELAZ-75310 of payload capacity 240 tonnes

It's designed for transportation of rock mass in difficult mining and technical conditions of deep mines, at mineral deposit open pits on technological roads under various climatic operating conditions (at ambient temperature from -50 to +50 °C).



Engine

Model	CUMMINS QSK 60-C
Four-cycle gas-turbocharged and intercooled direct diesel engine with V-type cylinders arrangement and electronic control system. The engine meets Tier1 toxic substances emission requirements.	
Gross power @ 1900 rpm, kW (hp)	1864(2500)
Maximum torque @ 1500 rpm, N.m	9839
Number of cylinders	16
Cylinders displacement, l	60,2
Cylinder diameter, mm	159
Piston stroke, mm	190
Specific fuel consumption, g/kW hr	206
Air cleaning is performed by three-stage filter with dry-type elements. Engine exhaust expulsion is performed through mufflers. Circulating lubrication system is pressurized and designed with "wet" crankcase. Double-loop fluid cooling system with forced circulation. Oil cooling is performed by oil-to-water heat exchanger. Cooling system impeller is actuated by fluid coupling with automatic control. Cooling system activation and desactivation is performed by means of thermostat.	
Fluid preheating system.	
Starting system is actuated by pneumatic starter.	
Air pressure in starting system, MPa	0,6-0,8
Electric equipment system voltage, V	24

Transmission

Transmission is equipped with alternating current - alternating current drive with traction alternator, two traction motors, motorized wheels planetary double-row reduction units, microprocessor-based control system and control devices, adjustment units.	
Transmission ratio	28,38
Maximum dump truck travel speed, km/h	64

Traction alternator	5GTA41B
Traction motor	5GEB34

Suspension

Suspension is conventional for front axle and driving axle and equipped with trailing arms, central joints and transversal rods. Cylinders are pneumohydraulic (nitrogen and oil) and equipped with inbuilt hydraulic shock absorber. Two cylinders are on the front axle and two cylinders are on the rear axle.	
Cylinder piston stroke, mm	
- front	320
- rear	290

Steering

Hydrostatic steering with steerable front wheels.	
Steering angle, degree	39
Turning radius, m	15
Overall turning diameter, m	34
The steering meets ISO 5010 requirements.	

Brakes

Dump truck brake system meets ISO 3450 international safety regulations and requirements. The system is equipped with service, parking, auxiliary and emergency brake systems.	
Service brake system is disk brakes with four brake gears per disk for front wheels and disk brakes with two brake gears per disk and automatic gap adjustment for rear wheels. The disks are mounted on traction motor shafts, actuator is hydraulic and separate for front and rear wheels.	
Parking brake system is permanently closed system with two brake gears of rear wheels per disk, spring actuator and hydraulic control.	
Auxiliary brake system is electrodynamic braking by traction motors with forced air cooling of brake resistors.	
Emergency brake system uses parking brake and operable circuit of service brakes.	
Brake resistors	17EM115
Power, kW	2770

Body

Welded bucket-type body with FOPS safety system, protective canopy, engine exhaust heating, device for mechanical fixing in raised position, rock-fenders and rock-ejectors.

Body capacity, m³:

struck	heaped 2:1
102,4	141,1

Frame

Frame is welded of high-strength low-alloy steel with application of cast elements at the maximum loading points and equipped with box-section variable-height side-members interconnected by cross-members.



Hydraulic system

Hydraulic system is combined for body dumping gear, steering and brakes actuator. The system is equipped with two-section variable-displacement axial-piston oil pump and three-stage telescopic body lifting cylinders with one stage of double action.

Body lifting time, s	22
Body lowering time, s	33
Maximum pressure in hydraulic system, MPa	18
Maximum pump delivery @ 1900 rpm, dm ³ /min	698
Filtration degree, mcm	10

Cab

Two-man two-door cab is equipped with air-sprung adjustable driver seat, additional trainee seat and adjustable steering column. The cab meets EN 474-1 and EN 474-6 requirements that specify permissible levels of in-cab noise, vibration, content of hazardous substances and dust.

Driver's workplace meets ROPS safety requirements.

In-cab noise level is not more than 80 dB(A).

Local vibration level is not more than 126 dB(A).

Overall vibration level is not more than 115 dB(A).

Tires

Radial tubeless air tires with quarry tread pattern.

Tire designation	40.00R57; 46/90R57
Inflation pressure, MPa	0,75; 0,7
Rim designation	32.00-57/6.0

Overall dimensions, mm*

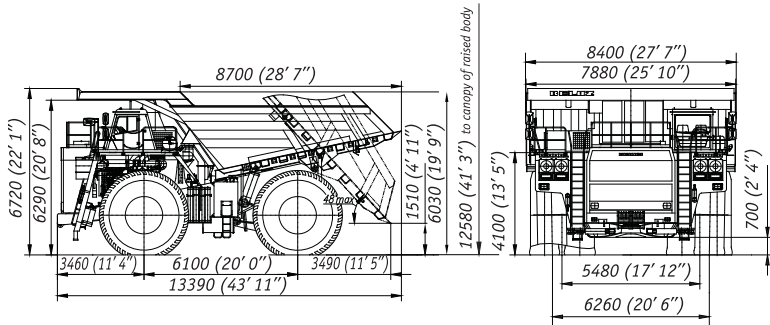

*Overall dimensions are specified for basic kitting-up of the dump truck

Refill capacities, l

Fuel tank	2900
Engine cooling system	650
Engine lubrication system	240
Hydraulic system	790
Reduction units of motorized wheels	230(115x2)
Suspension cylinders:	
- front	97,4(48,7x2)
- rear	103,0 (51,5x2)

Weight

Maximum payload capacity, kg	240000
Unladen weight, kg	161500
Gross weight, kg	401500
Dump truck weight distribution on axles, %:	
unladen	laden
front 45	33
rear 55	67

Special equipment

- Fire-fighting system (standard)
- Starting preheater (standard)
- Heating and conditioning unit (standard)
- Automatic lubrication system (optional)
- System of loading and fuel control (optional)
- Telemetering tire-pressure monitoring system (optional)
- Body floor lining (optional)
- Attention device of approach to high-voltage line (optional)

Towing and braking performance

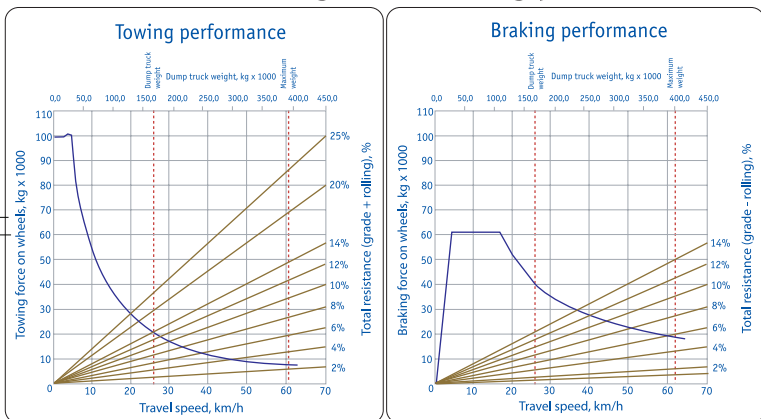

OJSC "Belarusian Autoworks" (BELAZ)
 40 let Oktyabrya str. 4, 222160, Zhodino, Republic of Belarus
 phone: +375 1775 3-60-67, 3-37-37, 3-27-82
 fax: +375 1775 7-01-37
 e-mail: office@belaz.minsk.by
 www.belaz.by