

Mine dump truck BELAZ-75571 of payload capacity 90 tonnes

It's designed for transportation of rock mass in difficult mining and technical conditions of deep mines, at mineral deposit open pits on technological roads under various climatic operating conditions (at ambient temperature from -50 to +50 °C).



Engine	
Model	CUMMINS QST30-C
Four-cycle gas-turbocharged and intercooled direct diesel engine with V-type cylinders arrangement and electronic control system. The engine meets Tier1 toxic substances emission requirements.	
Rated power @ 2100 rpm, kW (hp)	783(1065)
Maximum torque @ 1300 rpm, N.m	4630
Number of cylinders	12
Cylinders displacement, l	30
Cylinder diameter, mm	140
Piston stroke, mm	165,1
Specific fuel consumption at rated power, g/kW hr	204
Air cleaning is performed by three-stage filter with dry-type elements.	
Engine exhaust expulsion is performed through body.	
Circulating lubrication system is pressurized and designed with "wet" sump. Single-loop fluid cooling system with forced circulation.	
Oil cooling is performed by oil-to-water heat exchanger.	
Fluid preheating system.	
Starting system is actuated by pneumatic starter.	
Electric equipment system voltage, V	24

Transmission		
Hydromechanical transmission is equipped with pump drive, planetary gearbox with torque converter, automatic control system.		
The transmission cooling system is operated through heat exchangers.		
Maximum dump truck travel speed, km/h	55	
Gearbox ratios:		
gears	forward	reverse
1	4,75	4,03
2	3,45	
3	2,58	
4	1,87	
5	1,38	
6	1,00	

Suspension	
Suspension is conventional for front axle and driving axle and equipped with trailing arms, central joints and transversal rods. Cylinders are pneumohydraulic (nitrogen and oil) and equipped with inbuilt hydraulic shock absorber. Two cylinders are on the front axle and two cylinders are on the rear axle.	
Cylinder piston stroke, mm	
- front	260
- rear	210

Steering	
Hydrostatic steering with steerable front wheels.	
Steering angle, degree	38
Turning radius, m	11
Overall turning diameter, m	24
The steering meets ISO 5010 requirements.	

Brakes	
Dump truck brake system meets ISO 3450 international safety regulations and requirements. The system is equipped with service, parking, auxiliary and emergency brake systems.	
Service brake system is front wheels dry-type disk brakes and rear wheels multiple-disk oil-cooled brakes. Actuator is hydraulic and separate for front and rear wheels.	
Parking brake system is disk brake gear on final drive driving shaft with spring actuator and hydraulic control.	
Auxiliary brake system uses rear wheels multiple-disk oil-cooled brakes with hydraulic actuator. Braking by service brakes with the view of deceleration is effected by separate foot pedal.	
Emergency brake system uses parking brake and operable circuit of service brakes.	

Hydraulic system	
Hydraulic system is combined for body dumping gear, steering and brakes actuator. The system is equipped with gear-type oil pumps and three-stage telescopic body lifting cylinders with one stage of double action.	
Body lifting time, s	20
Body lowering time, s	19
Maximum pressure in hydraulic system, MPa	16,5
Maximum pump delivery @ 2100 rpm, dm ³ /min	464
Filtration degree, mcm	10

Body

Welded bucket-type body with FOPS safety system, protective canopy, engine exhaust heating, device for mechanical fixing in raised position, rock-fenders and rock-ejectors.

Body capacity, m³:

struck	heaped 2:1
37,7	53,3 (standard)
44,5	60,0 (optional)
75,0	93,3 (optional)

Frame

Frame is welded of high-strength low-alloy steel with application of cast elements at the maximum loading points and equipped with box-section variable-height side-members interconnected by cross-members.



Driving axle

Mechanical driving axle is equipped with single-stage bevel final drive, bevel differential with four pinions and planetary hub drives with spur pinions.

Ratios:

final drive	2,56
hub drive	7,44
driving axle total	19,05

Driveline

Driveline consists of two open-type cardan shafts with joints on needle bearings that join hydromechanical transmission to engine and driving axle. Flexible coupling is mounted between front cardan shaft and engine. Front cardan shaft is equipped with protective guard.

Cab

Two-man two-door cab is equipped with air-sprung adjustable driver seat, additional trainee seat and adjustable steering column. The cab meets EN 474-1 and EN 474-6 requirements that specify permissible levels of in-cab noise, vibration, content of hazardous substances and dust.

Driver's workplace meets ROPS safety requirements.

In-cab noise level is not more than 80 dB(A).

Local vibration level is not more than 126 dB(A).

Overall vibration level is not more than 115 dB(A).

Tires

Radial or diagonal tubeless air tires with quarry tread pattern.

Tire designation	27.00R49 or 31/90-49
Inflation pressure, MPa	0,6/0,65
Rim designation	19.5-49/4.0

Overall dimensions, mm*

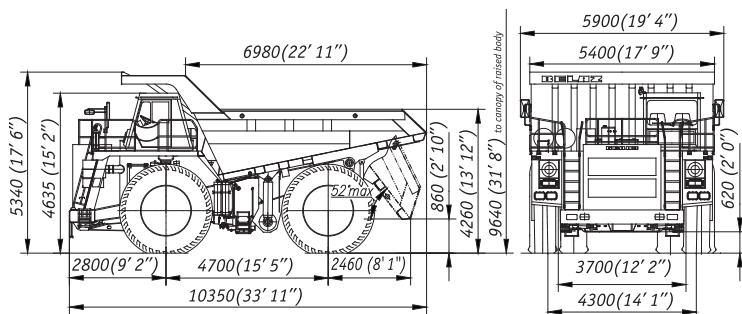

*Overall dimensions are specified for basic kitting-up of the dump truck

Weight

Maximum payload capacity, kg	90000
Unladen weight, kg	74000
Gross weight, kg	164000
Dump truck weight distribution on axles, %:	
unladen	
front	50,9
rear	49,1
laden	
front	33,0
rear	67,0

Refill capacities, l

Fuel tank	1400
Engine cooling system	380
Engine lubrication system	140
Hydraulic system	405
Hydraulic cooling system of multiple-disk oil-cooled brakes	360
Gearbox	120
Final drive	145
Hub drives	90 (45x2)
Suspension cylinders:	
front	33 (16,5x2)
rear	86 (43x2)

Special equipment

Fire-fighting system (standard)
 Preheating system (standard)
 Automatic lubrication system (standard)
 System of loading and fuel control (standard)
 Telemetering tire-pressure monitoring system (optional)
 Body floor lining (optional)

Towing and braking performance

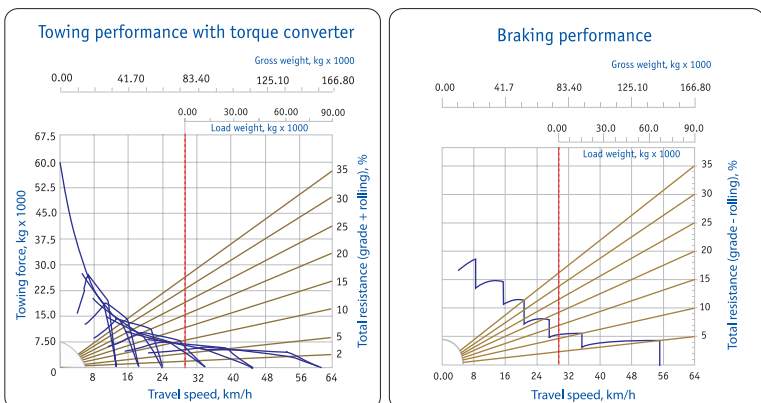

OJSC "Belarusian Autoworks" (BELAZ)
 40 let Oktyabrya str. 4, 222160, Zhodino, Republic of Belarus
 phone: +375 1775 3-60-67, 3-37-37, 3-27-82
 fax: +375 1775 7-01-37
 e-mail: office@belaz.minsk.by
 www.belaz.by