

# 2306D 5th wheel conversions



- Gross Power: 170 kW (228 hp)
- Gross Torque: 810 Nm (596 lbft)

**BELL**

# 2306D 5th wheel conversions

## STANDARD EQUIPMENT

### Body

- Jost 37C fifth wheel hitch
- Standard Bell dia 90 ball hitch fitted to customers height spec on rear plate
- Increased departure angle
- Trailer brake kit, integrated with EVB
- 2x Fire extinguishers fitted to mudguard

## OPERATING WEIGHTS

Empty:	Front	7 970 kg (17 571 lbs)
	Rear	4 710 kg (10 384 lbs)
	Total	12 680 kg (27 955 lbs)
Gross Combined Mass		45 300 kg (99 869 lbs)

## LINE DRAWINGS

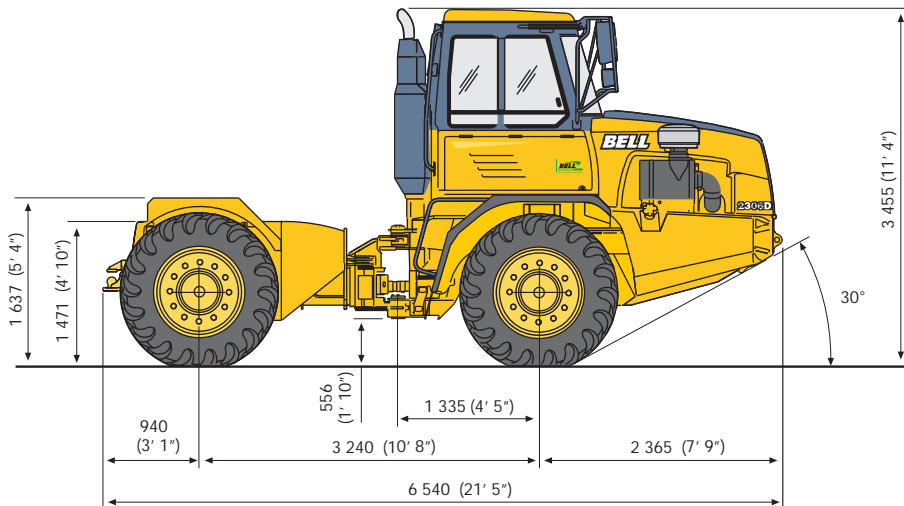

BELL SOUTH AFRICA : Tel: +27 (0)11-928 9700 • Fax: +27 (0)11-928 9702  
BELL INTERNATIONAL : Tel: +27 (0)35-907 9431 • Fax: +27 (0)35-797 4336  
E-mail: sales@bellequipment.com • www.bellequipment.com

All dimensions are shown in millimetres, unless otherwise stated between brackets. Under our policy of continuous improvement, we reserve the right to change specifications and design without prior notice. Photographs featured in this brochure may include optional equipment.

**Strong Reliable Machines**  
**Strong Reliable Support**

**BELL**