

B18D ^{18 000L} Water Tanker



Application Equipment

- Gross Power: 170 kW (228 hp)
- Gross Torque: 810 Nm (597 lbft)

BELL

B18D 18 000L Water Tanker

TANK

- 2 manholes 500 mm diameter, with hinged covers
- Anti-skid walkway on roof of tank
- Roof access ladder with handrails
- Three reinforced transverse baffles
- Two longitudinal reinforced baffles
- 6 mm Steel skin
- Superior low centre of gravity design for increased stability
- Three fixed spray nozzles with 180° spread
- Spray nozzles are automatically activated when pump is turned on in cab
- External water pump capable of 800 l/min
- Full pump speed is achieved at engine idle
- Flexible coupling between pump and motor
- One pump used for suction and spraying.

TANK

continued

- Selection is made using one lever at the rear of the tank
- Spray width 9 m
- Priming tap provided for easy priming of external suction line
- Level gauge (visible from driving station) is provided
- Tank is internally blasted and coated with special twin pack epoxy
- All main valves are stainless steel butterfly valves
- 6 m flexible external suction hose with foot valve and strainer

OPTIONAL

EQUIPMENT

High Capacity pump 1 200 l/min

LINE DRAWINGS

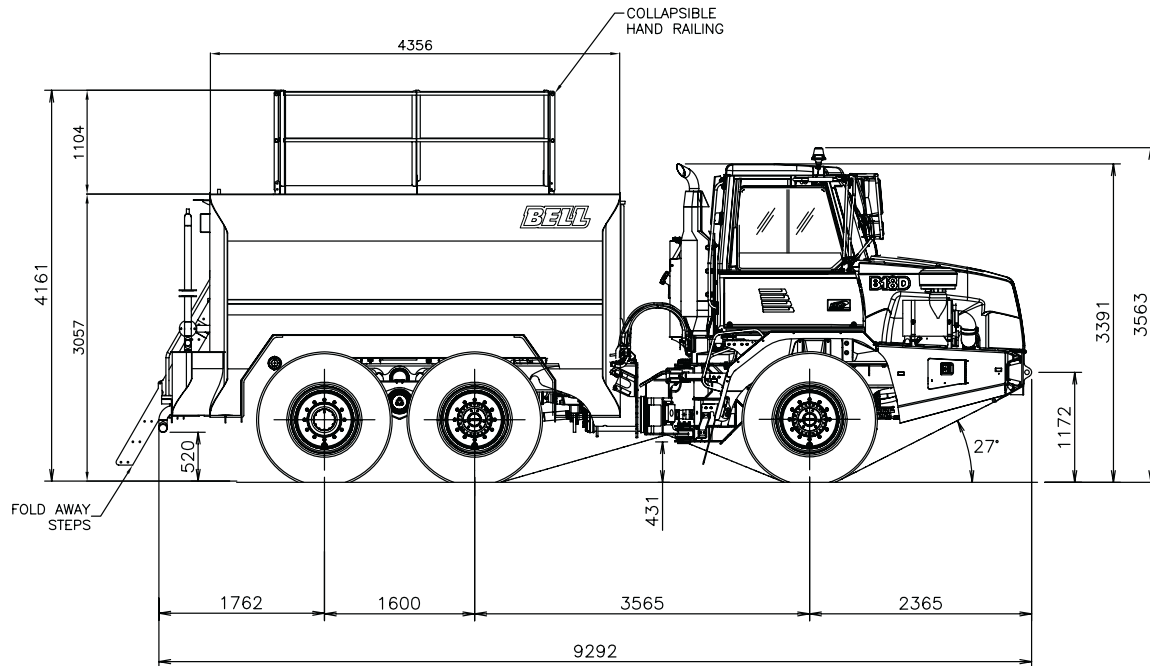



BELL INTERNATIONAL : Tel: +27 (0) 35 907 9431

 Tel: +27 11 928 9700

 Tel: +49 6631 911 30

 Tel: +33 555 89 23 56

 Tel: +34 918 796 019

 Tel: +7 495 771 20 27

 Tel: +44 1283 712 862

E-mail: sales@bellequipment.com • www.bellequipment.com

All dimensions are shown in millimetres, unless otherwise stated between brackets. Under our policy of continuous improvement, we reserve the right to change specifications and design without prior notice. Photographs featured in this brochure may include optional equipment.

Strong Reliable Machines
Strong Reliable Support

BELL