

B18D Concrete Mixer



- Gross Power: 170 kW (228 hp)
- Gross Torque: 810 Nm (597 lbft)

BELL

B18D Concrete Mixer

STANDARD EQUIPMENT

Mixer

- Water tank - aluminium
- 240 l - pressurized
- Spray hose with nozzle
- 2 400 mm discharge chute extension
- Lever controls - Drum direction and engine speed
- Inspection ladder

OPERATING WEIGHTS

Unladen

| | |
|--------|------------------------|
| Front | 8 096 kg (17,849 lbs) |
| Middle | 4 175 kg (9,204 lbs) |
| Rear | 4 175 kg (9,204 lbs) |
| Total | 16 447 kg (36,259 lbs) |

Laden

| | |
|--------|------------------------|
| Front | 9 397 kg (20,717 lbs) |
| Middle | 10 998 kg (24 246 lbs) |
| Rear | 10 998 kg (24,246 lbs) |
| Total | 31 393 kg (69,210 lbs) |

LINE DRAWINGS

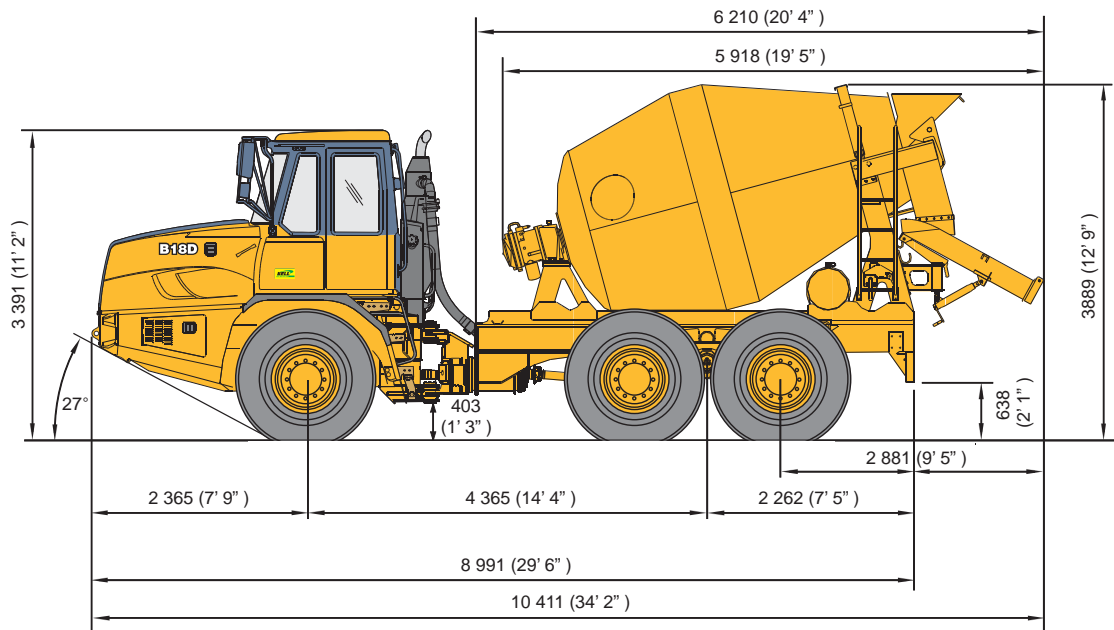



BELL INTERNATIONAL : Tel: +27 (0) 35 907 9431

 Tel: +27 11 928 9700

 Tel: +49 6631 911 30

 Tel: +33 555 89 23 56

 Tel: +34 918 796 019

 Tel: +7 495 771 20 27

 Tel: +44 1283 712 862

E-mail: sales@bellequipment.com • www.bellequipment.com

All dimensions are shown in millimetres, unless otherwise stated between brackets. Under our policy of continuous improvement, we reserve the right to change specifications and design without prior notice. Photographs featured in this brochure may include optional equipment.

Strong Reliable Machines
Strong Reliable Support

BELL