

B25D ^{23 000L} Water Tanker



- Gross Power: 205 kW (275 hp)
- Gross Torque: 1 000 Nm (735 lbft)

BELL

B25D ^{23 000L} Water Tanker

TANK

- 2 manholes 500 mm diameter, with hinged covers
- Anti-skid walkway on roof of tank
- Roof access ladder with handrails
- Three reinforced transverse baffles
- Two longitudinal reinforced baffles
- 6 mm Steel skin
- Superior low centre of gravity design for increased stability
- Three fixed spray nozzles with 180° spread
- Spray nozzles are automatically activated when pump is turned on in cab
- External water pump capable of 800 l/min
- Full pump speed is achieved at engine idle
- Flexible coupling between pump and motor
- One pump used for suction and spraying. Selection is

TANK

continued

- made using one lever at the rear of the tank
- Priming tap provided for easy priming of external suction line
- Level gauge (visible from driving station) is provided
- Tank is internally blasted and coated with special twin pack epoxy
- All main valves are stainless steel butterfly valves
- 6 m flexible external suction hose with foot valve and strainer
- Spray width 9 m

OPTIONAL

EQUIPMENT

High capacity pump 1 200 l/min

LINE DRAWINGS

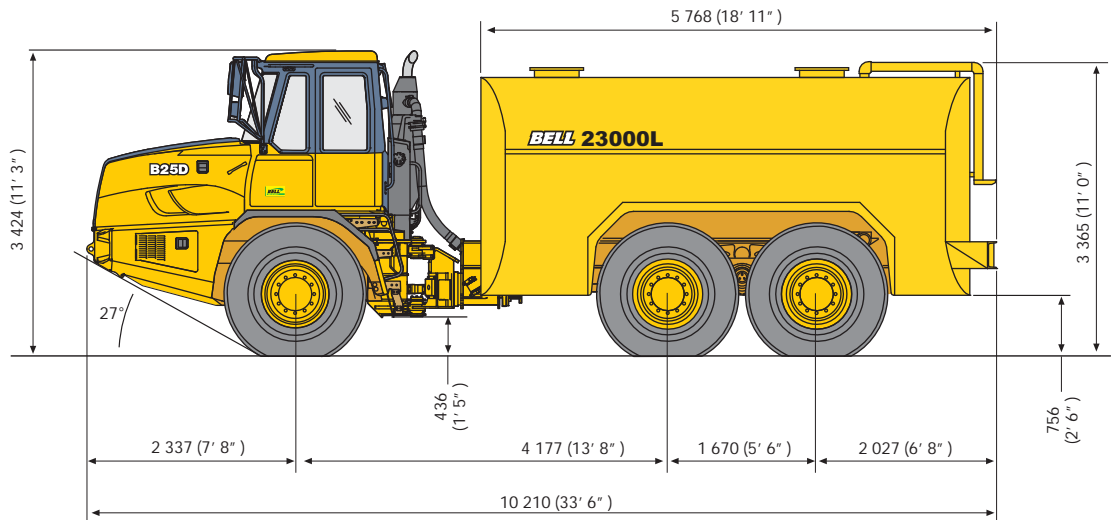

BELL SOUTH AFRICA : Tel: +27 (0)11-928 9700 • Fax: +27 (0)11-928 9702
 BELL INTERNATIONAL : Tel: +27 (0)35-907 9431 • Fax: +27 (0)35-797 4336
 E-mail: sales@bellequipment.com • www.bellequipment.com

All dimensions are shown in millimetres, unless otherwise stated between brackets. Under our policy of continuous improvement, we reserve the right to change specifications and design without prior notice. Photographs featured in this brochure may include optional equipment.

Strong Reliable Machines
Strong Reliable Support **BELL**