



Volvo BM L70B



- **Engine output gross:**
SAE J1349 93 kW (126 hp)
- **Operating weight: 9,8 – 11,5 t**
(21600 – 25400 lb)
- **Buckets: 1,6 – 5,0 m³**
(2,1 – 6,5 yd³)
- **Torque Parallel Linkage**
 - high breakout torque throughout the working range
 - excellent parallel lift-arm action
- **6-cylinder Volvo engine**
 - good low rpm lugging performance
- Hydrodynamic transmission with Volvo BM Automatic Power Shift
- Enclosed wet oil circulation-cooled brakes
- **Care Cab** – pressurized cab with high comfort and safety
- **Contronic** monitoring system
- **Load-sensing hydraulic system**
 - Working and steering hydraulics
- Stable and easy-to-operate precision steering
- Pilot-operated working hydraulics
- Power take off for hydraulically powered attachments (option)

VOLVO BM



SERVICE

Contronic monitoring system gives: Information on regular service. Minimized time for troubleshooting. Information on the condition of the machine.

Service accessibility: Large, easy-to-open engine access panels with gas struts. Hinged radiator grill and radiator.

Fuel tank	190 l	(50 US gallon)
Hydraulic tank	65 l	(17 US gallon)



ENGINE

Engine delivers high torque even at low rpm. Quick response from low rpm even under full load. The machine can work at low engine speeds, which contributes to good fuel economy, less noise, less wear and longer life.

Engine: Volvo TD 61 GD or Volvo TD 63 KDE, 6-cylinder, in line, direct-injected, turbocharged 4-stroke diesel engine with wet replaceable cylinder liners.

Air cleaning: three-stage.

Engine	TD 61GD	TD 63KDE*		
Flywheel output at	36,6 (2200)	35,0 (2100)	r/s	(r/min)
SAE J1349/ISO 9249 net	87 (118)	87 (118)	kW	(hp)
Max. torque at	20 (1200)	18,3 (1100)	r/s	(r/min)
SAE J1349/ISO 9249 net	495 (365)	610 (450)	Nm	(lbf ft)
Displacement	5,48 (334)	5,48 (334)	l	(in ³)

* Low-emission high-performance engine

Torque curve

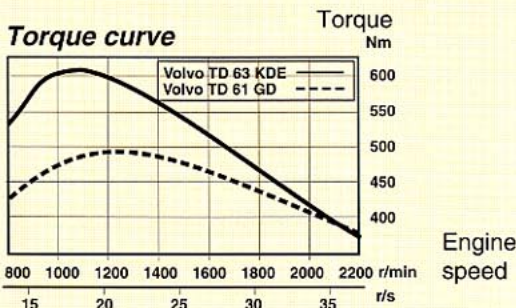

ELECTRICAL SYSTEM

Contronic monitoring system with complete information on the status of the machine's various systems. Electrical system with circuit board well protected by fuses. Prepared for retrofitting of optional equipment.

Central warning

Central warning lamp for the following functions: engine oil pressure, engine coolant temperature (with buzzer), hydraulic oil pressure in transmission, transmission oil temperature, brake pressure, parking brake (buzzer).

Voltage	24	V	
Batteries	2x12	V	
Battery capacity	2x105	Ah	
Cranking capacity, ea	575	A	
Reserve capacity, ea	170	min	
Alternator rating	1680 / 60	W/A	
Starter-motor output	5,4	kW	(7,3 hp)



DRIVETRAIN

Drivetrain and working hydraulics well-matched to each other. Dependable design. Quick acceleration boosts productivity. Volvo BM system-compatible design facilitates service.

Torque converter: Single-stage

Transmission: Volvo BM Power Shift transmission of countershaft type with single-lever control. Fast and smooth forward/reverse shifting.

Shifting system: Volvo BM Automatic Power Shift (APS).

Axes: Volvo BM, fully floating axle shafts with planetary-type hub reductions. Cast-steel axle housing. Fixed front axle and oscillating rear axle. 100% differential lock on front axle (option).

Transmission	Volvo BM HT90		
Torque converter	2.85:1		
Speeds			
forward/reverse	High	Low (option)	
1	6 (4)	1,7 (1,1)	km/h (mile/h)
2	12 (8)	3,5 (2,2)	km/h (mile/h)
3	24 (15)	6,5 (4,0)	km/h (mile/h)
4 (forward only)	41 (26)	12,0 (7,6)	km/h (mile/h)
Measured with tires	17.5 R 25*		
Front and rear axle	Volvo BM / AWB 15		
Oscillation, rear axle	±13 °		
Ground clearance at 13° oscillation	420 mm		



BRAKE SYSTEM

Simple, reliable system with few parts ensures high availability and safety. Self-adjusting internal oil circulation-cooled disc brakes give long service intervals.

Service brakes: Volvo BM, dual-circuit system with accumulators. Fully hydraulically operated enclosed internal oil circulation-cooled disc brakes. Transmission declutch during braking can be preselected.











Parking brake: Mechanically operated drum brake on front axle input shaft.

Secondary brake: One of the service brake circuits or the parking brake fulfills the safety requirements.

Number of discs/wheel	1
Number of accumulators	3
Volume, each	0,5 l (0,13 US gal)

The brake system complies with the requirements of ISO 3450, SAE J1473 and StVZO § 41

BUCKETS

Specifications with 17,5 R25* GP2B tires and counterweight 1	Standard buckets								Coal/snow	Wood chips	
											
Volume, heaped	m ³	1,6	1,6	1,8	1,8	1,8	1,8	1,9*	1,9*	3,0	5,0
	yd ³	2,1	2,1	2,35	2,35	2,35	2,35	2,5	2,5	3,9	6,5
Static tipping load, straight	kg	7630	7190	7550	7490	7120	7060	7350	6930	6520	6380
at 35° turn	(lb)	16820	15840	16650	16510	15700	15560	16200	15280	14370	14060
	kg	6820	6390	6740	6680	6330	6260	6540	6140	5760	5610
	(lb)	15030	14090	14870	14730	13950	13800	14430	13540	12700	12360
at full turn	kg	6570	6150	6500	6440	6090	6020	6300	5900	5340	5370
	(lb)	14490	13560	14330	14190	13420	13280	13890	13010	12200	11850
Breakout force	kN	101	92	94	94	86	86	90	83	65	55
	(lbf)	22700	20640	21180	21180	19400	19400	20140	18550	14660	12280
A	mm	6770	6870	6850	7040	6940	7130	6920	7020	7300	7610
	(ft in)	22'3"	22'7"	22'6"	23'1"	22'9"	23'5"	22'8"	23'	23'11"	24'11"
L	mm	4950	4880	5010	5010	5060	5060	5010	5060	5220	5500
	(ft in)	16'3"	16'	16'5"	16'5"	16'7"	16'7"	16'5"	16'7"	17'1"	18'1"
H	mm	2920	2850	2870	2750	2810	2680	2820	2750	2570	2370
	(ft in)	9'7"	9'4"	9'5"	9'	9'3"	8'10"	9'3"	9'	8'5"	7'10"
M	mm	960	1020	1010	1150	1070	1210	1040	1100	1350	1560
	(ft in)	3'2"	3'4"	3'4"	3'9"	3'6"	4'	3'5"	3'7"	4'5"	5'1"
N	mm	1570	1600	1590	1670	1620	1690	1590	1620	1670	1700
	(ft in)	5'2"	5'3"	5'3"	5'6"	5'4"	5'7"	5'3"	5'4"	5'6"	5'7"
V	mm	2500	2500	2500	2500	2500	2500	2500	2500	2550	2650
	(ft in)	8'2"	8'2"	8'2"	8'2"	8'2"	8'2"	8'2"	8'2"	8'4"	8'8"
a, clearance radius	mm	5610	5630	5630	5710	5650	5730	5650	5670	5780	5920
	(ft in)	18'5"	18'6"	18'6"	18'9"	18'7"	18'10"	18'7"	18'7"	18'11"	19'5"
Operating weight	kg	10000	10200	10020	10060	10240	10280	10130	10340	10380	10750
	(lb)	22000	22480	22080	22180	22560	22660	22100	22780	22880	23700
Order No.		92291	92243	92560	92562	92282	92561	92560	92282	92564	92565

BUCKET SELECTION CHART

The volume handled is often greater than is indicated by the bucket's ISO/SAE classification.
The table shows optimum bucket choice with regard to the material.

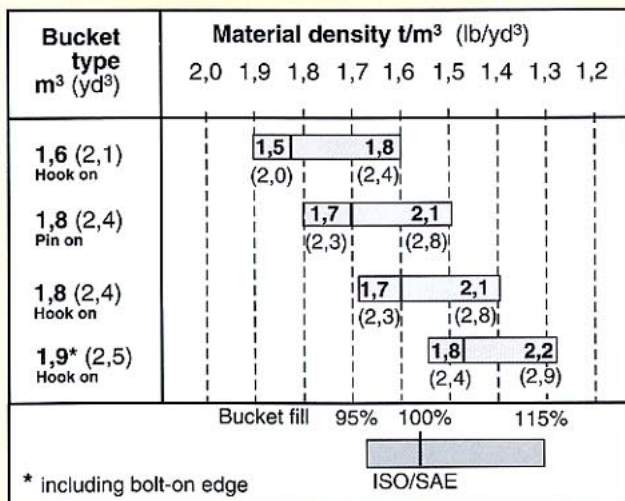

Material	Bucket fill %	Density t/m ³	Density lb/yd ³
Soil	100 – 115	1,4 – 1,6	2400 – 2700
Clay	110 – 120	1,4 – 1,6	2400 – 2700
Sand	100 – 110	1,6 – 1,9	2700 – 3200
Gravel	100 – 110	1,7 – 1,9	2900 – 3200
Rock	75 – 100	1,5 – 1,9	2500 – 3200

Counterweight 1 may be used in all handling.

Counterweight 2 may only be used for stabilizing purposes within timber and pallet handling on flat surface. This counterweight is not allowed in combination with tires 20,5-25 and it also replaces hydroinflation of rear tires.

Combination of counterweights 1+2 may only be used in extreme cases for stabilizing purposes within timber and pallet handling with fork attachments. Only when working on firm and flat surface.

CHANGE IN DIMENSIONAL DATA

	Width mm (in)	Ground clearance mm (in)	Tipping load at full turn kg (lb)	Operating weight kg (lb)
Tyres 20.5 R 25 XHA L3	+ 80 (+3,2")	+ 56	+250 (+550)	+ 440 (+ 970)
Tyres 17.5 R 25 XHA L3	± 0	± 0	± 0	± 0
Tyres 17.5-25 SGL	+10 (+0,4")	- 10 (- 0,4")	- 120 (- 260)	- 180 (- 400)
Tyres 600-26.5	+260 (+10,3")	- 10 (- 0,4")	- 120 (- 260)	- 60 (- 130)
Counterweight 2	-	-	+570 (+1260)	+360 (+790)
Excl. counterweight 1	-	-	- 330 (- 730)	- 190 (- 420)

DIMENSIONS VOLVO BM L70B

Tyres: 17.5R25*GP2B Good Year

B	5704 mm	(18'9")
C	2840 mm	(9'4")
D	390 mm	(1'3")
F	3120 mm	(10'3")
G	2140 mm	(7')
J	3550 mm	(11'8")
K	3810 mm	(12'6")
O	56 °	
P	45 °	
R	44 °	
R ₁ *	48 °	
S ₁ *	78 °	
T	90 mm	(3,5")
U	360 mm	(1'2")
X	1860 mm	(6'1")
Y	2310 mm	(7'7")
Z	3570 mm	(11'9")
a ₂	5050 mm	(16'7")
a ₃	2750 mm	(9')
a ₄	40 ± °	

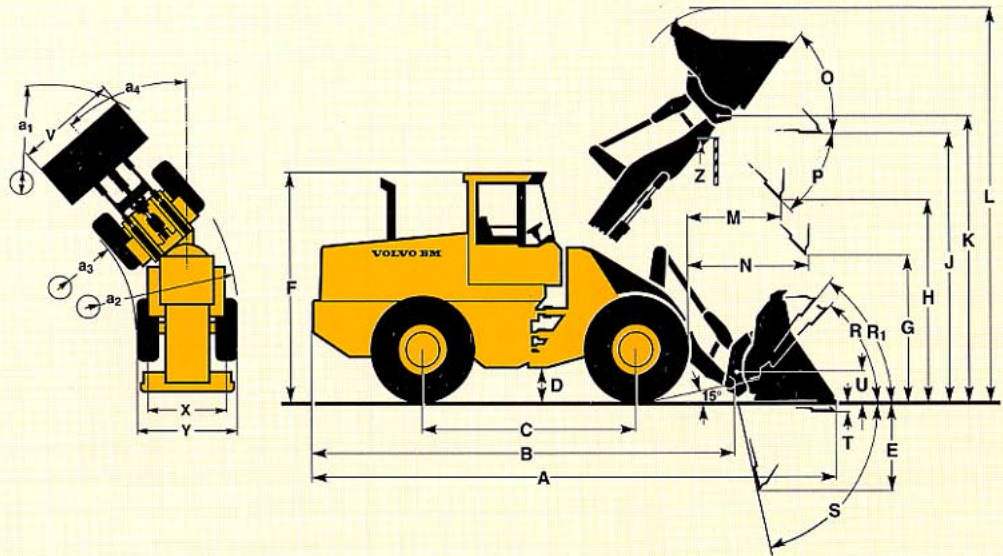

LOG GRAPPLE No. 92019

Tyres: 17.5R25*GP2B Good Year

A	1,2 m ²	(12,9 ft ²)
B	3360 mm	(11')
C	1550 mm	(5'1")
D	2880 mm	(9'5")
E	1240 mm	(4'1")
F	1480 mm	(4'10")
G	2410 mm	(7'11")
H	4280 mm	(14')
I	5810 mm	(19'1")
J	1980 mm	(6'6")
K	2150 mm	(7'1")
L	1810 mm	(5'11")
M	7460 mm	(24'6")

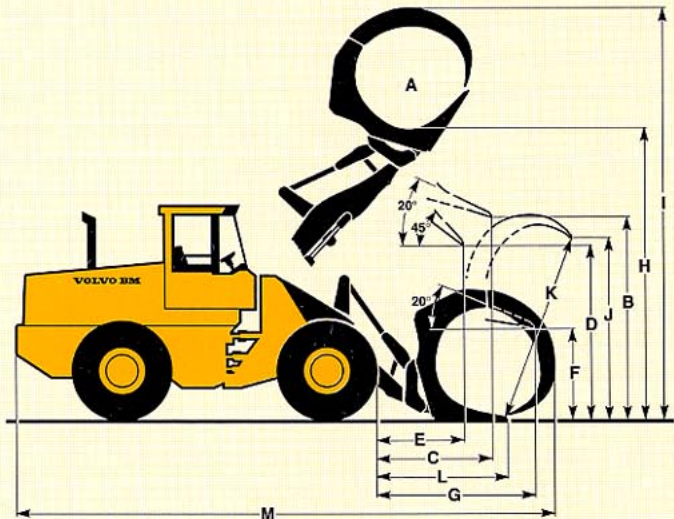

Operating weight	10590 kg	(23350 lb)
Operating load	3200 kg	(7048 lb)

PALLET FORK No. 97789

Tyres: 17.5R25*GP2B Good Year

Fork tine order no. one tine	97789
Length	1225 mm (4')
Fork frame order no.	91177
Width	1500 mm (4'11")
Rated operating load*	3425 kg (7544 lb)
at load center distance	600 mm (2')
Operating weight	10140 kg (22350 lb)

A	940 mm	(3'1")
B	1660 mm	(5'6")
C	40 mm	(1'5")
D	1720 mm	(5'8")
E	3600 mm	(11'10")
F	800 mm	(2'8")

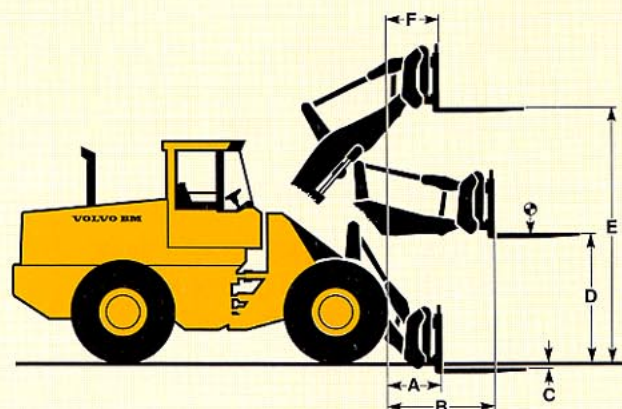

* acc. to std EN 474-3; firm and level ground.



STEERING SYSTEM

Low-effort steering gives short work cycle times. Power-efficient system for good fuel economy. Good directional stability and smooth ride.

Steering system: Load-sensing hydrostatic articulated steering.

System supply: The steering system has prioritized feed from the machine's load-sensing axial piston pump.

Pump: Double variable-flow axial piston pump.

Cylinders: Two double-acting cylinders.

Relief pressure	21	MPa	(3050 psi)
Max. flow	80	l/min	(21,1 USgal/min)
Max steering angle	± 40°		



CAB

Care Cab with easy entry and wide door opening. Lined with sound-absorbent material. Sound- and vibration-suppressing suspension.

Good all-round visibility, large glazed areas. Curved windshield of laminated, green-tinted glass.

Ergonomically located controls and instruments permit better operating position.

Instrumentation: All information important to the operator is readily visible in front of him. Cab display for **Contronic** monitoring system (optional equipment).

Heater and defroster: Heating element with filtered fresh air and four-speed fan. Defroster outlets for all windows.

Operator's seat: Spring suspended, adjustable operator's seat with lap belt. The seat is mounted on a bracket on the rear wall. The force from the lap belt is absorbed by the seat rails.

Emergency exits	3		
Sound level in cab			
as per ISO 6396, max.	75	dB (A)	
Ventilation	10	m ³ /min	(350 ft ³ /min)
Heating capacity	11	kW	(37500Btu/h)
Air conditioning (optional)	7	kW	(24000 Btu/h)

Tested and approved according to the following standards:

ROPS (ISO/CD 3471, SAE J1040), FOPS (ISO 3449, SAE J231). Complies with "Overhead guards for rider lift trucks" (ISO 6055) and "Operator Restraint System" (SAE J386).



HYDRAULIC SYSTEM

Load-sensing (LS) hydraulics distribute exactly the quantity of oil required for the function used. Load sensing gives precise control of the hydraulics throughout the lifting range. High pump capacity provides quick movements.

Pump: The load-sensing double axial piston pump adjusts the oil requirements of the function used via indication through a LS line. The flow is directed to the function used via a central valve block. Steering function always has priority.

Valve: Double-acting 2-spool valve. The control valve is actuated by a 2-spool pilot valve.

Lift function: The valve has four functions: raise, neutral, lower and float. Inductive/magnetic automatic boom kickout (option) can be switched on and off. Adjustable to any position between maximum reach and full lift height.

Tilt function: The valve has three functions: rollback, neutral and dump. Inductive/magnetic automatic bucket positioner, that can be switched on and of.

Cylinders: Double-acting

Filter: Full-flow filtration through 20 µm HEPA filter cartridge.

Axial piston pump

Relief pressure	26,0	MPa	(3770 psi)
Flow	160	l/min	(42,2 US gal/min)
at	10	MPa	(1450 psi)
and engine speed	36,7	r/s	(2200 r/min)

Pilot system

Relief pressure	3,5	MPa	(510 psi)
-----------------	-----	-----	-----------

Cycle times

Raise *	5,1	s
Dump *	1,3	s
Lower, empty	3,0	s
Total cycle time	9,4	s

* with load as per ISO 5998 and SAE J818

LIFTARM SYSTEM

TP Linkage combines high breakout torque throughout the working range with nearly exact parallel lift-arm action. These features, together with high lift height and long reach, make the lift-arm system just as good in bucket loading as in work with fork attachments and material handling arms.

STANDARD EQUIPMENT

Safety & comfort

Cab:
 ROPS (SAE J1040CC) (ISO 3471),
 FOPS (SAE J 231) (ISO 3449).
 Acoustical Lining
 Ashtray
 Cigarette Lighter
 Door Lockable (left side access)
 Heater/Defroster/Pressurizer
 11 kW (37500 Btu/h) with Four-
 Speed Blower Fan
 Filtered Air
 Floor Mat
 Interior Light
 Interior Rearview Mirror
 Mirrors Rearview (2), Exterior
 Openable Window, right-hand side
 Safety Glass, Tinted
 Seat Belt (SAE J386)
 Seat, Heated, Ergonomically
 Designed, Suspension Adjustable
 Steering Wheel, Adjustable Tilt
 Storage Compartment
 Sun Visor
 Windshield Washer, Front & Rear
 Windshield Wiper, Front & Rear
 Intermittent Wiper, Front
 Cab Access Steps and Handrails
 Fenders, Small, Front & Rear with
 Anti-Skid-Tape

Engine & electrical system

Air Cleaner, Dry Type, Dual
 Element, Exhaust Aspirated
 Precleaner

Coolant filter
 Coolant Level, Sight Gauge
 Engine Intake Manifold Preheater
 Exhaust Rain Cap (built in)
 Muffler, Spark Arresting
 Electrical System 24 V
 Pre-wired for Optional
 Accessories
 Alternator, 24 V, 60 A
 Battery Disconnect Switch
 Fuel Gauge
 Hourmeter
 Horn, Electric
 Reverse Alarm (SAE J994)
 Instrument Panel with Symbols
 Lights:
 Driving (2-Fornt), Halogen with
 High/Low Beam
 Parking Lights
 Stop/Tail Combination (2 rear)
 Turn Signals with Hazard
 Warning Switch
 Working Lights, Halogen (2
 front, 2 rear)
 Instrument Lightning
 Contronic Monitoring System, ECU
 Contronic Display
 Neutral Start Feature
 Test Function for Warning &
 Monitoring Lights
 Warning & Monitoring Lights:
 Engine Oil Pressure
 Engine Coolant Temperature
 Air Cleaner Restriction
 Alternator Malfunction
 Working Lights
 High Beam Driving Lights

Direction Indicator, Hazard
 Warning Flasher
 Transmission Oil Pressure
 Transmission Oil Temperature
 Brake System Pressure
 Parking Brake Applied
 Hydraulic Oil Level

Central warning (with buzzer):

Engine Oil Pressure
 Engine Coolant Temperature
 (Buzzer)
 Transmission Oil Pressure
 Transmission Oil Temperature
 Brake System Pressure
 Parking Brake Applied and
 Transmission in Forward or
 Reverse (buzzer)
 Hydraulic Oil Level

Drivetrain

Transmission: modulated
 with single lever
 control, automatic
 power shift, and operator
 controlled declutch
 Differentials:
 front, hydraulic differential lock
 rear, conventional
 Tires 17,5-25/12 L2 SGL
 Good Year

Brake System

Wet, internal Oil Circulation
 Cooled Disc Brakes, 4-wheel,
 Dual Circuit
 Brake System, Secondary
 Parking Brake Alarm

Hydraulic system

Main Valve, 2-Spool, Pilot
 Operated
 Pilot Valve, 2-spool
 Dual Axial Piston Pump
 Attachment Bracket with Separate
 Locking System
 Bucket Lever Detent
 Bucket Leveler, Automatic with
 Position Indicator, Adjustable
 Boom Lever Detents
 Boom Kickout, Automatic,
 Adjustable
 Hydraulic Control Lever Safety
 Latch
 Boom Lowering System
 Hydraulic Pressure Test Ports,
 Quick Connect
 Hydraulic Fluid Level, Sight Gauge
 Hydraulic Oil Cooler

External Equipment

Counterweight 1
 Drawbar with Pin
 Isolation Mounts:
 Cab, Engine, Gearbox
 Lifting Lugs
 Side Panels, Engine Hood
 Steering Frame Lock
 Vandalism Lock, Provison for:
 Batteries
 Engine Oil

OPTIONAL EQUIPMENT

Service and maintenance equipment

Tool box
 Tool kit

Engine equipment

Low Emission Version
 Cold Starting Aid, Engine Coolant
 Preheater (120 V/1500 W) or
 (240 V/ 1500 W)

Electrical equipment

Working Lights Front, extra
 Working Lights Rear, extra
 Rotating Beacon, Amber with
 Collapsible Mount

Transmission equipment

Forward and Reverse Switch
 Transmission, 8-speed

Cab equipment

Installation Kit for Radio
 Radio
 Instructor's Seat
 Hand Throttle
 Sliding Ventilation Window
 Speedometer
 Air suspended Operator's seat
 Retractable Seat Belt
 Air Conditioner 7 kW,
 (24000 Btu/h)
 Dual Service Brake Pedals

Hydraulic equipment

Hydraulic Control, 3rd Function
 Hydraulic Control, 4th Function
 Hydraulic Controls, 5th/6th Funct.
 Hydraulic Power Take Off
 – Load Sensing
 Hydraulic Power Take Off
 – Heavy Duty

Hydraulic Single Acting Lifting
 Function
 Boom Suspension System

External equipment

Fenders, extended
 Counterweight II
 Other equipment
 Comfort Drive Control (CDC)
 Slow Moving Vehicle Emblem
 Secondary Steering

Tires

17.5-25
 17.5 R 25*
 20.5-25
 20.5 R 25*

Protective equipment

Protective grids for front running
 light
 Protective grids for rear working
 lights
 Protective grids for rear lights
 Anti-Vandalism equipment

Attachments

Buckets
 Fork Equipment
 Material Handling Arm
 Timber Grapples
 Diagonal Snow Blade
 Broom
 Bale Clamp
 Asphalt Cutter
 Cutting Edge, 3 pc Reversible
 Bolt-On
 Bucket Teeth, Bolt-On
 Bucket Spillguard

Under our policy of continuous product improvement, we reserve the right to change specifications and design without prior notice. The illustrations do not necessarily show the standard version of the machine.

Specifications and dimensions conform in applicable parts to ISO 7131, SAE J732, ISO 7546, SAE J742, ISO 5998, SAE J818.

VME Industries Sweden AB

S-63185 ESKILSTUNA SWEDEN

Ref. No. 21 2 669 2201 ENGLISH

Printed in Sweden 10.05.94