

D-series

ARTICULATED DUMP TRUCKS
Mk VI

B25D | B30D | B35D | B40D | B50D



D SERIES

BELL

Get more from your truck

If you're looking to deliver more to your bottom line, choose Bell Articulated Dump Trucks.

These D-series ADTs handle heaped payloads with faster cycle times and best-in-class fuel efficiency - so you'll move more material at lower cost. They're highly reliable, too, with high-strength, welded-alloy steel chassis and components that are durable and optimised for no unnecessary weight. And with their oscillating frame joint, articulated steering, and high-floatation tyres, these hard working haulers won't let wet weather or steep grades dampen your plans.



• Extensive use of high-strength, lightweight materials gives these trucks the best payload-to-mass ratios and hauling efficiencies in each class.

• With their oscillating frame and high-floatation tyres, Bell trucks won't leave you stuck on muddy, rutted or hilly terrain.

• The redesigned sound-suppressed cab features fatigue-beating controls, advanced diagnostic monitor and a sealed-switch module for convenient, fingertip operation of numerous functions.

• Fuel-efficient Tier 3 emission-certified engines deliver clean power without compromise in all conditions. Leading-edge emissions technology ensures rapid engine response and dependable cold-start performance.

Specifications	B25D	B30D	B35D	B40D	B50D
Gross power	205 kW	240 kW	290 kW	315 kW	390 kW
Operating mass					
Empty	18 400 kg	18 690 kg	28 230 kg	29 850 kg	34 520 kg
Loaded	41 600 kg	45 990 kg	60 730 kg	66 851 kg	79 920 kg
2:1 heaped capacity	13,8 m ³	16,6 m ³	20,1 m ³	22,6 m ³	27,5 m ³
Rated payload	23 200 kg	27 300 kg	32 500 kg	37 000 kg	45 400 kg

Add enhancements such as a Tier 3 emission-certified engine, solid state electrical system and spacious, redesigned cab with refined controls, and you have everything you need to maximise uptime and productivity.

- Limited-slip differentials (B25D to B30D), controlled traction differentials (B35D to B50D) and transfer case diff-lock provide a traction boost in poor underfoot conditions.
- The best-in-class payload-to-weight ratio means that more of your fuel cost is spent moving the material, not the machine - decreasing your cost per tonne.
- The fully automatic six-speed planetary transmission with torque converter lock up maximises fuel efficiency.
- Automatic retardation slows the truck when the operator backs off the accelerator pedal - for more confidence on steep grades and enhanced brake life.
- Electronic unit injection and common-rail fuel systems provide high injection pressures even at low engine speed for improved cold-starting ability, low-speed response, and reduced emissions.
- High-travel suspension keeps all tyres in constant ground contact for optimum traction.
- The short front end provides an industry-best approach angle that allows these ADTs to attack steep terrain.



1

1. Transfer case inter-axle differential delivers equal torque to each axle when traction is favourable. When conditions get ugly, engage the diff-lock on the go to deliver torque to the tyres that can best use it.



2

2. The central oscillation joint, high suspension travel on all axles, and balanced weight distribution provide the agility and ability to navigate hostile terrain.

3. Front-suspension damping helps minimize vibration, while the centre-mounted seat reduces the roll often experienced in off-road conditions - for comfortable productivity.

4. Available tailgate helps retain more material for bigger loads. It automatically opens as dump body is raised.



3



4



Haul of Fame

Bell ADTs give you the competitive edge. Boasting faster haul cycles and industry-leading fuel economy, they move material at the lowest cost per tonne of any comparable-size truck. Best in-class payload-to-mass ratio gives you more power and agility to carry the load, for maximum productivity and profitability. What really sets these apart from other material movers is their ability to thrive on rough terrain, steep grades and mud. Try one to appreciate the difference.



Built for comfort

What operator wouldn't want to climb behind the wheel of a Bell ADT? It's spacious, quiet, climate-controlled cab is loaded with productivity-boosting comfort and convenience features that rival some SUVs.

From the state-of-the-art multifunction monitor and fully customisable controls to air-suspension seat, tilt/telescoping steering wheel and optional CD player with high-output speakers, the D-series provides everything your operators need to perform at their best. Unparalleled comfort.

- Who says you can't take it with you? There's a place for a coffee cup, in-door storage for an insulated flask or other carry-ons, and even a hot/cold box for refreshments.



- An intuitive monitor reveals vital operating information, detailed diagnostic readings of most sensors and switches and dump body function settings.



- Convenient sealed switch pad provides fingertip control of numerous productivity enhancing functions including: **Dump body upper limit. Soft stop / hard stop selection, I-Tip and Speed Control.**



- The standard sound-suppression package significantly reduces noise levels and operator fatigue.

- The adaptive transmission control adjusts clutch engagement to ensure smooth, consistent shifts throughout the life of the truck.

- A fully adjustable air-suspension seat is optimally positioned behind the front axle to help smooth out the ride when the going gets rough.

- Easy-to-understand instruments and intuitive controls wrap around the operator so they're easier to view and operate.

- A heavy-duty bi-level climate-control system with automotive-style louvres keeps the glass clear and cab comfortable.

- The spacious centre-mount seat and a comprehensive mirror package provide exceptional all-around visibility.

- You won't find retarder pedals or levers in a Bell truck. Retarder aggressiveness is simply set on the switch pad. Everything else is automatic.

Our innovative Comfort Ride system...

...is available as an option on the B35, B40 and B50 trucks to even further enhance ride comfort by ensuring minimal whole body vibration exposure. Productivity increases, through increased cycle times, and reduced haul road maintenance are even further benefits of the simple, but extremely successful system. Long haul cycles with rough, hard roads will see maximum benefit, especially on the unladen run.

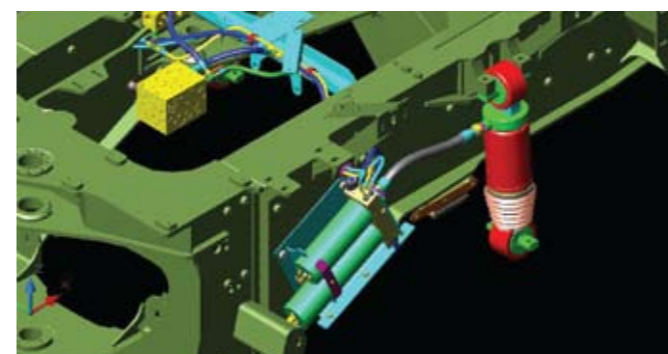

The front suspension consists of independent suspension cylinders that allow the oil flow and pressure to be constantly changed to minimise the effects of machine movement. Sensors in the frame continually measure and accommodate for bumps in the surface while lateral sensors also measure any roll and constantly adjust cylinders to accommodate for this.



The incorporation of the dual stage sandwich block allows for differing suspension characteristics between laden and unladen runs. The simple mechanical solution has proved durable while being extremely effective in smoothing out the ride.

Nothing's built as strong as a Bell

Built smarter to work harder, these lean machines boast the material-moving muscle you need without the mass to feed.

Their lower mass reduces powertrain and structural stress.

Other uptime-boosting features include

enhanced diagnostics,

solid-state sealed

switches and re-inforced articulation joints to list but

a few. When you know how they're built, you'll run a Bell.



Automatic transmission retardation provides superior braking power and reduces service brake wear.

Hydraulically actuated dry-disc brakes deliver consistent "on-the-mark" braking, even in cold weather. Simplified design makes them easy to maintain.

Oil-immersed wet-disc brakes on the B50D and B40D (optional on B35D and B30D) are virtually maintenance-free.

B50D and B40D hydraulic, transmission, and service brake oil coolers employ a hydraulically driven fan that runs only as needed, helping conserve power and fuel.

Efficient viscous direct-drive fans in all Bell trucks provide engine and charge-air cooling.

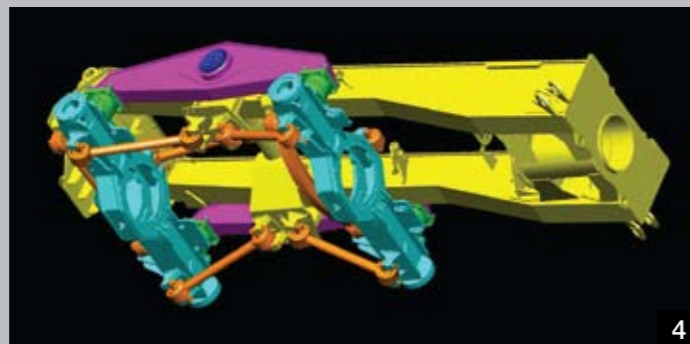

1. The high-strength steel chassis delivers strength and rigidity without excess weight.
2. Planetary powershift transmission controls optimise shift points and protect the transmission from operator error and abuse. Thicker clutch plates, generous lubrication flow, and heavy-duty cooling ensure long life.
3. High-strength steel and widely spaced taper roller bearings in the articulation area enhance long-term durability.
4. Rough terrain demands tough suspensions such as the kind on a Bell ADT. Heavy-duty components absorb shocks and come back for more. You get best-in-class ground clearance, too.

Here's the lowdown on daily operating costs

You won't have to dig deep to uncover the many ways we've simplified service and made the D-series less expensive to maintain. Easy-to-reach dipsticks, see-through reservoirs, sight gauges and grouped service points make quick work of the daily routine. High-hour oil and filter change intervals reduce costs and planned downtime. Quick-change filters and extended engine and hydraulic oil-service intervals reduce costs and provide more uptime. Plus, an advanced diagnostic monitor and diagnostic test ports help you troubleshoot problems and make informed maintenance decisions.

- The engine dipstick and oil fill, oil and fuel filters and coolant reservoir are readily accessible.
- Available environmental drains allow quick, no-spill changes.
- Engine, transmission and hydraulic oil-change intervals of 500 hrs and 2 000 hrs add up to more uptime and less expense.
- The load-sensing hydraulic system was designed with simplicity in mind. Fewer components result in greater reliability and service ease.
- Your Bell Service Centre has the parts and back-up you need to stay productive and offers a wide variety of preventative maintenance and support programmes to help you control costs.

1. The cab can be tilted without special tools in minutes, for convenient service access to drivetrain components.



2. If something goes wrong, the diagnostic monitor provides service codes and supporting info to help you quickly pinpoint the problem.



3. Easily accessible test ports allow technicians to troubleshoot problems more quickly.

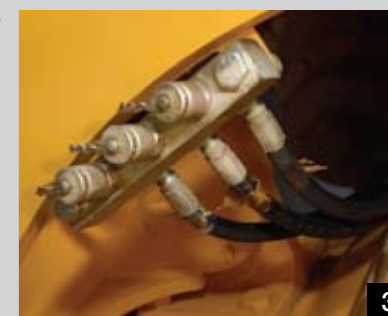

4. An in-cab load centre simplifies fuse replacement. Fewer relays, connectors and harnesses mean higher reliability.



5. See-through fluid reservoirs (B25D and B30D) and sight gauges let you check fluid levels at a glance.



6. The centralised lube bank places difficult-to-reach nipples within reach. The convenient lube chart helps ensure that nothing gets overlooked.



Safety is our Business too

By listening to our customers and reacting quicker to a changing workplace we provide a vehicle that exceeds application safety standards.



The exclusive on-board weighing option presents the operator with real time information on the payload while the machine is being loaded. A 'limp home' mode can also be activated if the machine is significantly over-loaded.



The park brake automatically applies when neutral is selected and it is not possible to engage neutral at speed. Torque dependent park brake release (hill assist) ensures no roll back on slopes.



The best in class retarder and engine braking automatically applies when the operator lifts his foot off the accelerator. Retarder aggressiveness can be simply adjusted on the sealed switch module ensuring maximum descent control for all conditions.

All trucks can be set up to automatically sound the horn when starting or switching between forward and reverse.

The incorporation of a Pitch and Roll sensor in the vehicle allows the bin to not be operated if the truck is in an unsafe position.



Keyless start, driver identity, and access codes ensures no unauthorized operation of your equipment.



Reverse cameras are available for factory or on site fitment ensuring full view when reversing.



Full hand-rails (to ISO 2876) can be installed to provide even more safety when performing engine checks.



Both operator or site selectable maximum speed control allows the vehicle to automatically decelerate and apply the retarder to prevent onsite speeding.



Optional Tyre pressure - monitoring System ensures that the operator has real time information on all tyres pressure and temperature conditions.



Where ever you are...

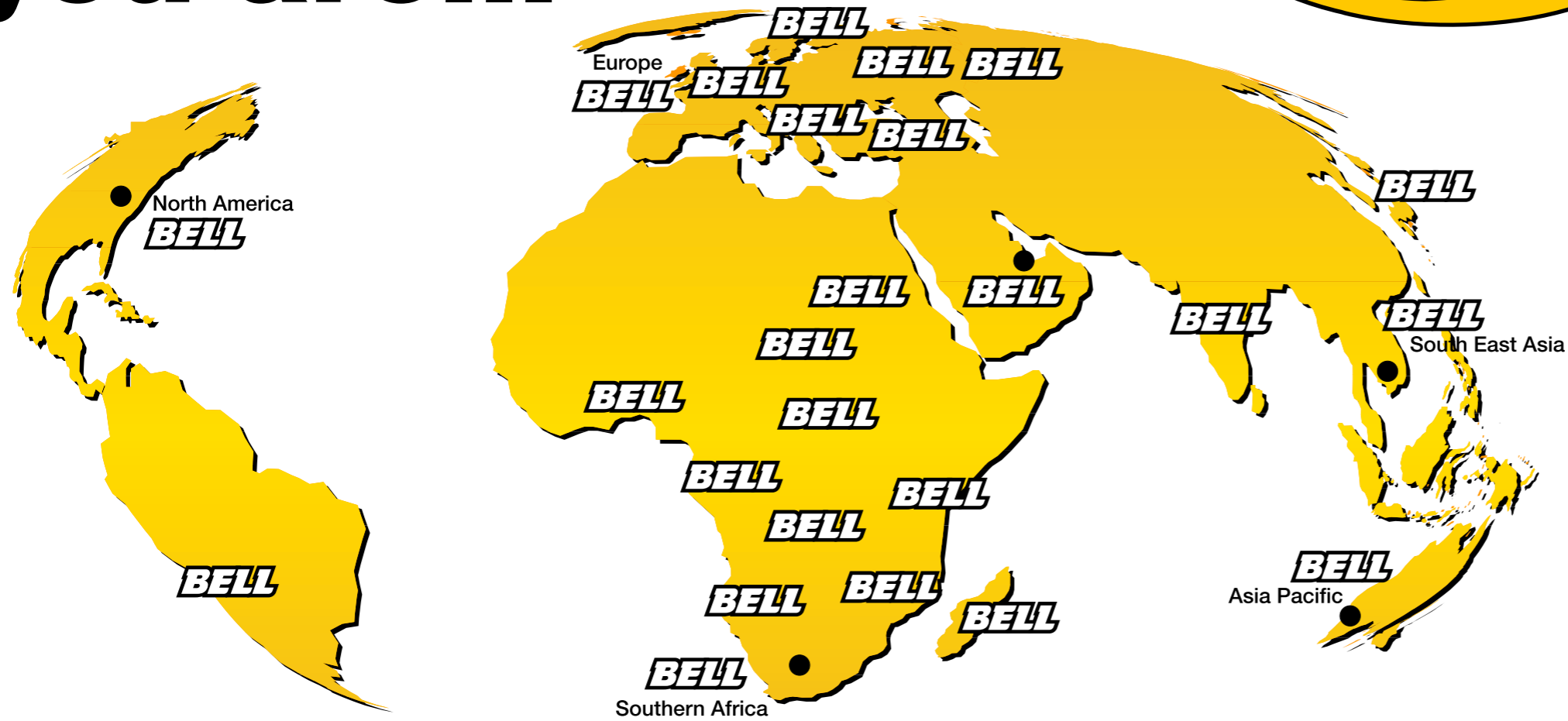

...we got you covered

Through our own Network as well as approved dealers and strategic alliances we can supply and support to the Global market. Develop a lasting and meaningful partnership with Bell Equipment through Bell Assure, your tailor made support structure furnished with all the after-sales tools you need to give you best value, peace of mind and a unique aftersales experience.

South African Manufacturing Facility



Global Logistics Center



German Manufacturing Facility



Used - Through the Bell Equipment used network, global opportunities can be explored to ensure best residual value when upgrading your trucks. Used units include full condition assessments guaranteeing peace of mind as well as different options to meet your criteria and budget.



Finance - Finance options can be tailored to your business needs through strong partnerships in all regions. Professional interaction and industry know how ensures fast and easy access to packages that meet your business profile - helping you win.



Parts - We believe there is more to Bell Equipment Company than simply our machines. We have an international network of dealers and subsidiaries stocking genuine Bell Parts you would expect available immediately. We pride ourselves that all care is taken to ensure the quality of replacement Bell Parts we stock meets the same stringent quality requirements as the parts we use in building our machines.



Technical Support - Bell Customer Support centres are located in key positions throughout all territories in which we operate to ensure that Bell Equipment is able to effectively support its products worldwide through parts availability and technical backup. As the worlds one stop shop, Bell Equipment also provides factory direct support for a full line of solid equipment 24 hours a day 365 days a year through Bell Technical Support. Such support includes Factory Technical Analysts, International Product Support, Training and complete literature.

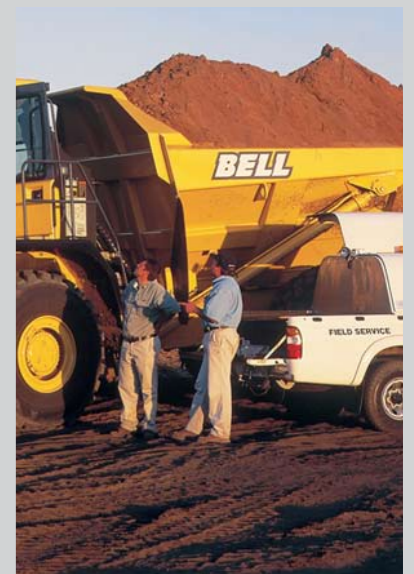

Fleetmatic - Fleet management just got smarter. In its quest to provide lowest cost per tonne solutions to its customers and push the boundaries of earthmoving technology, Bell Equipment has developed Fleetm@tic, its own remote satellite fleet management tool.



Fleet management just got smarter



Bell Fleetm@tic is an essential tool in running your business whether used for optimising your production, controlling your fleet or detecting any losses. The cutting edge Fleetm@tic technology keeps Bell owners in touch with their equipment all the time. It provides accurate up-to-date operational data, production data, fault data as well as machine location and movements, in a cost effective and effortless manner.

Packages:

Fleetm@tic Std gives a daily report. This data includes position, tonnage, fuel, distance and speed; in effect all of the information from the previous day. Reports are available in a downloadable daily, weekly and monthly format.

Fleetm@tic Max has all the features of Std, and in addition packaged production data is sent every shift. Reports can be split by up to three different shifts. Ten event messages per day are also included in the reports. Events can also be set up for immediate reporting via a predetermined cell phone number.

Fleetm@tic Max Plus has all the features of Std and Max, but offers virtually real-time monitoring. Packaged data is also sent at ignition on and off, and at loading and tipping. Individual load cycle reports are also available. For instance it is possible to see the machine's location within the last several minutes, or fuel consumption and tonnage for the last haul cycle for virtual real-time control.

Information below is included in the basic data download.

- Date
- Odometer (km)
- Hours
- Tonnes moved
- Loads
- Distance
- Fuel level (litres)
- Fault codes
- Fuel burn (l/hr)
- Idle time laden (%)
- Idle time un-laden (%)
- Overload (%)
- Speed (km/h)
- Over rev count
- Brake usage (%)
- Events
- Cycle Times

Easily Locate and track your machine on an interactive web based map, which allows you to zoom into your worksite to within several meters. Cutting edge Iridium technology ensures global coverage and unsurpassed reliability. Geofence boundaries can easily be set up with notification to both operator and owner when these boundaries have been crossed.



Receive on-line or email reports that cover each machine in your fleet. Reports cover everything you need to manage your site effectively. A Spreadsheet format can also be simply downloaded which will allow you to manipulate the data to meet your current reporting structure. All data can also be sorted by operator based on their individual code that is entered on the vehicle before startup.



Historic playback allows you to check on which route and stockpiles are being worked on to ensure optimal efficiency. Data can be used to reconstruct events, giving you all the information to take any corrective action. Time bar reporting is also beneficial to those machines out on rent.

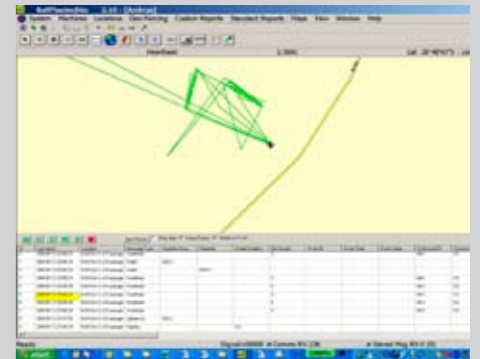

Solid state, sealed componentry ensures maximum reliability in even the harshest environments.



Specifications

B25D

B30D

	B25D	B30D
ENGINE	Mercedes Benz inline 6 cylinder, turbocharged, intercooled, low emission diesel engine	Mercedes Benz inline 6 cylinder, turbocharged, intercooled, low emission diesel engine
Gross power	205 kW (275 hp) @ 2,200 rpm	240 kW (322 hp) @ 2,200 -1,600 rpm
Net Power	198 kW (265 hp) @ 2,200 rpm	232 kW (311 hp) @ 2,200 -1,600 rpm
Gross torque	1,000 Nm (736 lbft) @ 1,200 -1,600 rpm	1,250 Nm (922 lbft) @ 1,200 - 1,600 rpm
Net torque	970 Nm (714 lbft) @ 1,200 -1,600 rpm	1,200 Nm (885 lbft) @ 1,200 - 1,600 rpm
Displacement	6,37 litres (389 cu.in)	7,2 litres (439 cu.in)
Fuel tank capacity	340 l (90 US gal)	340 l (90 US gal)
Auxiliary Brake	Exhaust brake Engine Valve Brake (EVB)	Exhaust brake Engine Valve Brake (EVB)
Certification	OM 906 LA.111/4-00 meets Europe (EU) step2; OM 906 LA.E3A/1 meets Europe (EU) step 3	OM 926 LA.111/4-00 meets Europe (EU) step 2; OM 926 LA.E3A/1 meets Europe (EU) step 3
TRANSMISSION	Engine mounted, fully automatic ZF planetary transmission with six forward gears and one reverse gear.	Engine mounted, fully automatic ZF planetary transmission with six forward gears and one reverse gear.
Torque Converter	Hydrodynamic with lock-up in all gears.	Hydrodynamic with lock-up in all gears.
Model	6HP592C Ecomat 2 plus	6HP592C Ecomat 2 Plus
Control Type	Electronic	Electronic
TRANSFER BOX	Remote mounted	Remote mounted
Manufacturer	VGR	VGR
Model	13100	13100
Layout	Three in-line helical gears.	Three in-line helical gears.
Output Differential	67/33 torque proportioning, Pneumatically lockable on the move.	67/33 torque proportioning, Pneumatically lockable on the move.
AXLES	High strength steel fabricated with spiral bevel type gears on the limited slip locking differential and heavy duty outboard planetary gears.	High strength steel fabricated with spiral bevel type gears on the limited slip locking differential and heavy duty outboard planetary gears.
Model	Bell 15T	Bell 18T
BRAKING SYSTEM	Dual circuit, full hydraulic actuation caliper brakes on all wheels	Dual circuit, full hydraulic actuation caliper brakes on all wheels
SERVICE BRAKE	164 kN (36,900 lbf)	164 kN (36,900 lbf)
Maximum brake force	Spring applied, air released driveline mounted disc.	Spring applied, air released driveline mounted disc.
PARK & EMERGENCY	396 kN (89,000 lbf)	396 kN (89,000 lbf)
Maximum brake force	Automatic exhaust brake and Engine Valve Brake (EVB)	Automatic exhaust brake and Engine Valve Brake (EVB)
AUXILLIARY BRAKE	442 kW (593 hp)	442 kW (593 hp)
Maximum retardation		
WHEELS	Earthmover	Earthmover
Tyre	23.5R25	23.5R25
FRONT SUSPENSION	Semi-independent, quad rubber mounted leading arm linkages supported by nitrogen and oil filled struts.	Semi-independent, quad rubber mounted leading arm linkages supported by nitrogen and oil filled struts.
REAR SUSPENSION	Pivoting walking beams, distributing equal load through laminated rubber suspension blocks. Each axle is coupled to the chassis by four rubber-bushed links for ideal vertical movement. Full load sensing system incorporating a ground driven emergency steering pump.	Pivoting walking beams, distributing equal load through laminated rubber suspension blocks. Each axle is coupled to the chassis by four rubber-bushed links for ideal vertical movement. Full load sensing system incorporating a ground driven emergency steering pump.
HYDRAULIC SYSTEM	184 l/min (48.6 gal/min)	184 l/min (48.6 gal/min)
Flow	25 Mpa (3,915 psi)	25 Mpa (3,915 psi)
Pressure	10 micron	10 micron
Filter		
STEERING SYSTEM	Hydrostatically actuated, low effort, fast acting.	Hydrostatically actuated, low effort, fast acting.
Lock to lock turns	Two double-acting steering cylinders	Two double-acting steering cylinders
Steering Angle	4.1 +-45°	4.1 +-45°

	B25D	B30D
DUMPING SYSTEM	Two double-acting, single stage, dump cylinders	Two double-acting, single stage, dump cylinders
Raise Time	12 s	12 s
Lowering Time	6 s	6 s
Tipping Angle	70°	70°
PNEUMATIC SYSTEM	Air drier with heater and integral unloader valve, serving park brake and auxilliary functions	Air drier with heater and integral unloader valve, serving park brake and auxilliary functions
System Pressure	810 kPa (117 psi)	850 kPa (123 psi)
ELECTRICAL SYSTEM	24 V	24 V
Voltage	Two maintenance free permanently sealed	Two maintenance free permanently sealed
Battery Type	2 X 105 Ah	2 X 105 Ah
Battery Capacity	28 V 80 A	28 V 80 A
Alternator Rating		
VEHICLE SPEEDS	1st 2nd 3rd 4th 5th 6th R 8 13 22 31 44 53 8 km/h 5 8 14 19 28 33 5 mph	1st 2nd 3rd 4th 5th 6th R 8 13 22 31 44 53 8 km/h 5 8 14 19 28 33 5 mph
OPERATING MASSES	UNLADEN LADEN	UNLADEN LADEN
Front	9,620 kg (21,208 lbs) 12,860 kg (28,351 lbs)	9,710 kg (21,407 lb) 13,350 kg (29,432 lbs)
Middle	4,420 kg (9,744 lbs) 14,400 kg (31,747 lbs)	4,490 kg (9,899 lb) 16,320 kg (35,979 lbs)
Rear	4,360 kg (9,612 lbs) 14,340 kg (31,614 lbs)	4,490 kg (9,899 lb) 16,320 kg (35,979 lbs)
Total	18,400 kg (40,565 lbs) 41,600 kg (91,712 lbs)	18,690 kg (41,204 lb) 45,990 kg (101,391 lbs)
GROUND PRESSURE	UNLADEN LADEN	UNLADEN LADEN
Front	92 kPa (3,5 psi) 250 kPa (36psi)	95 kPa (13.8 psi) 271 kPa (39 psi)
Middle	43 kPa (6 psi) 303 kPa (44 psi)	47 kPa (6.8 psi) 337 kPa (49 psi)
Rear	41 kPa (6 psi) 302 kPa (44psi)	46 kPa (6.7 psi) 337 kPa (49 psi)
LOAD CAPACITY	10,8 m ³ (14,1 cu.yd)	12,9 m ³ (16,9 cu.yd)
Struck Capacity	13,8 m ³ (18,1 cu.yd)	16,6 m ³ (21.7 cu.yd)
SAE 2:1 Capacity	16,9 m ³ (22.1 cu.yd)	20,3 m ³ (26.6 cu.yd)
SAE 1:1 Capacity	14,5 m ³ (19 cu.yd)	17,4 m ³ (22.8 cu.yd)
SAE 2:1 Capacity with Autogate		
Rated Payload	23 200 kg (51,147 lbs)	27 300 kg (60,186 lbs)

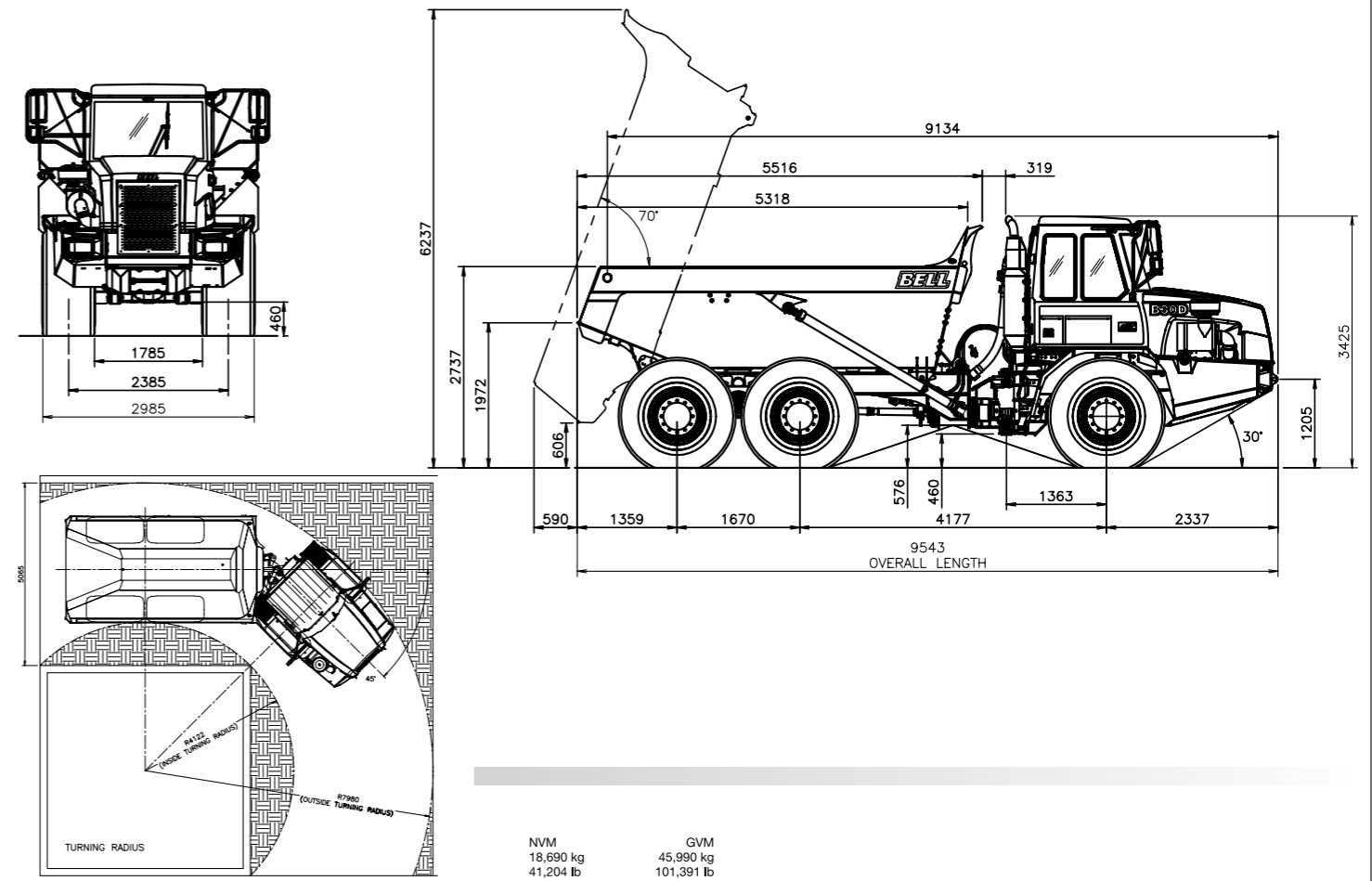
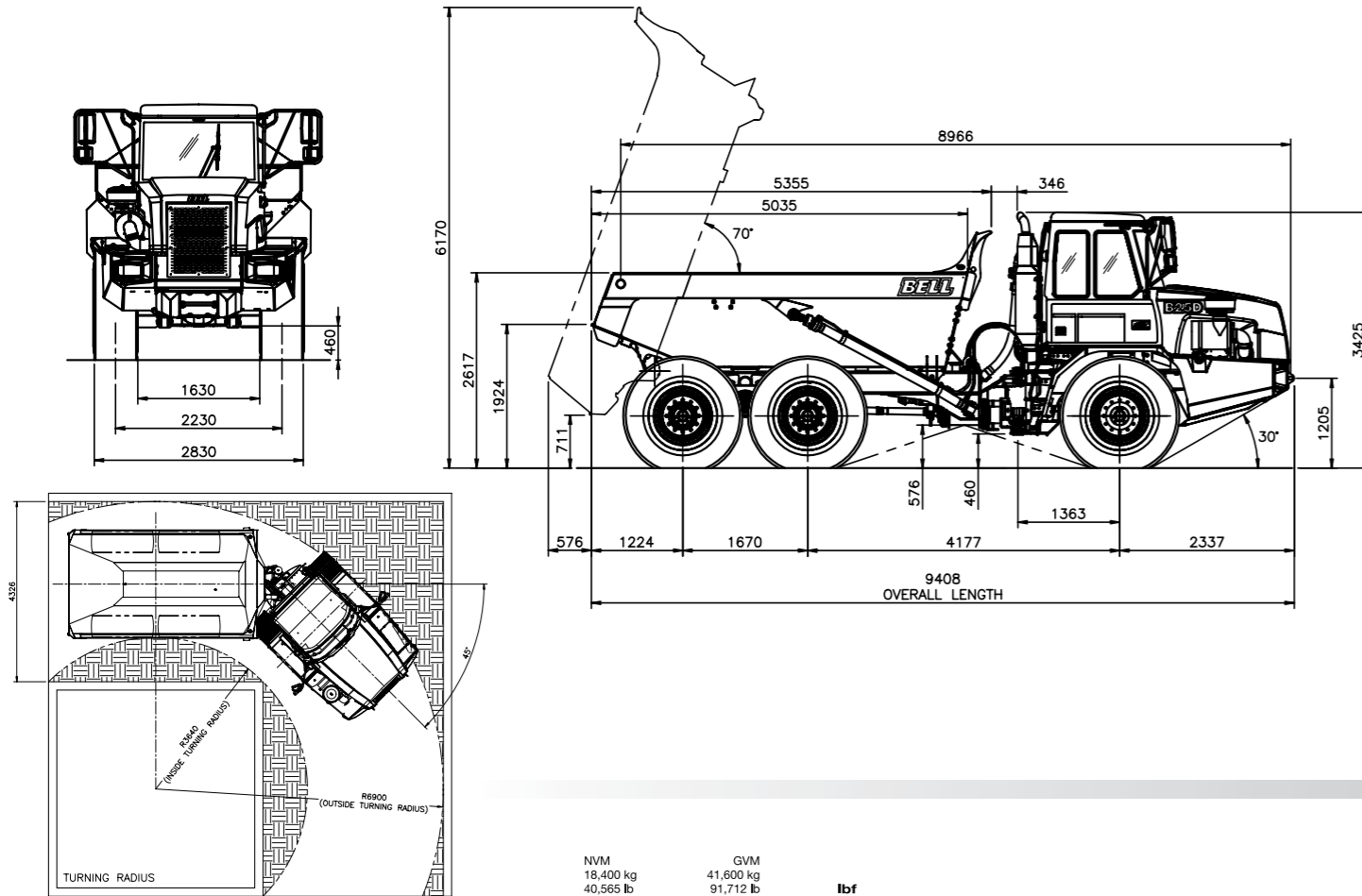

GRADEABILITY

1. Determine tractive resistance by finding intersection of vehicle mass line and grade line. NOTE: 2% typical rolling resistance is already assumed in chart and grade line.
2. From this intersection, move straight left across charts until line intersects rimpull curve.
3. Read down from this point to determine maximum speed attained at that tractive resistance.

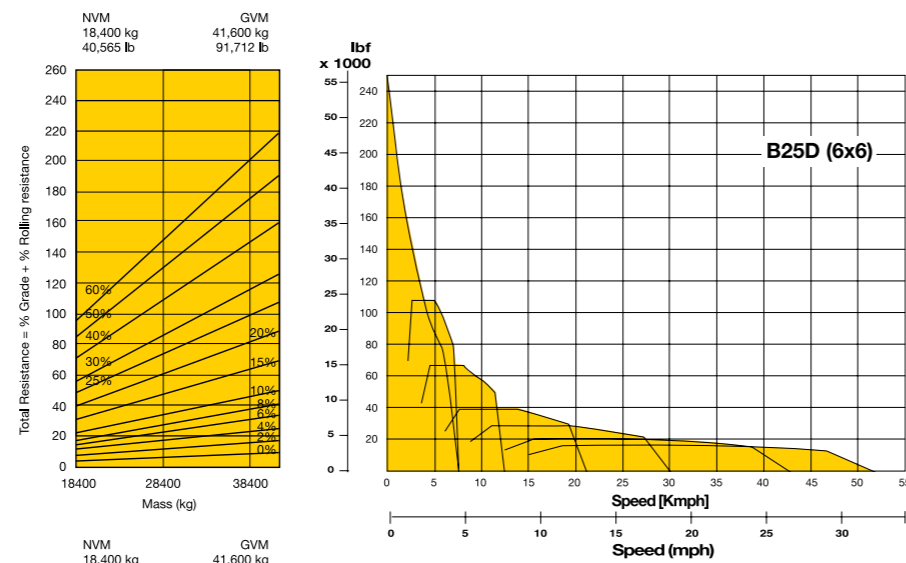

GRADEABILITY

1. Determine tractive resistance by finding intersection of vehicle mass line and grade line. NOTE: 2% typical rolling resistance is already assumed in chart and grade line.
2. From this intersection, move straight left across charts until line intersects rimpull curve.
3. Read down from this point to determine maximum speed attained at that tractive resistance.

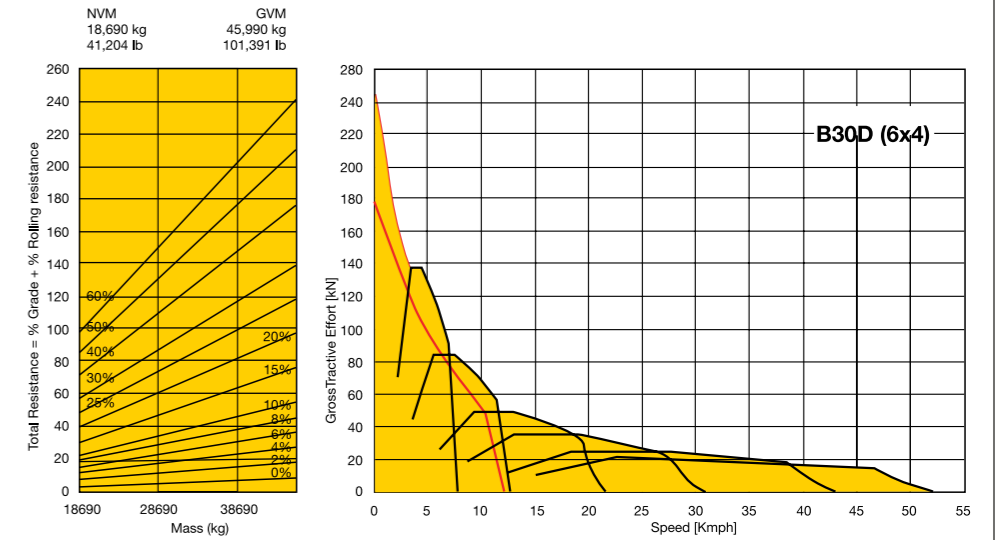

RETARDATION

1. Determine retardation force required by finding intersection of vehicle mass line.
2. From this intersection, move straight left across charts until line intersects the curve. NOTE: 2% typical rolling resistance is already assumed in chart.
3. Read down from this point to determine maximum speed.

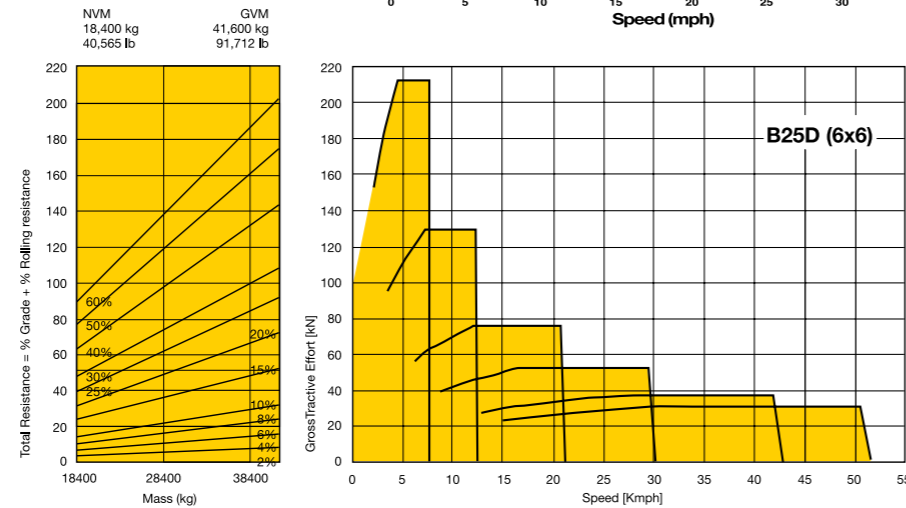

RETARDATION

1. Determine retardation force required by finding intersection of vehicle mass line.
2. From this intersection, move straight left across charts until line intersects the curve. NOTE: 2% typical rolling resistance is already assumed in chart.
3. Read down from this point to determine maximum speed.

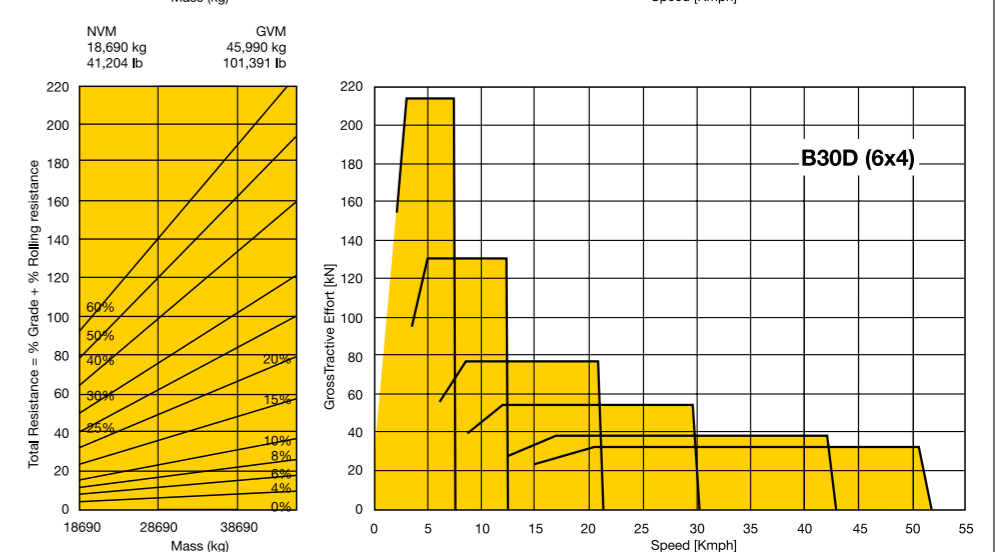

Specifications

B35D

B40D

	B35D	B40D
ENGINE	Mercedes Benz V6, turbocharged, intercooled, low emission diesel engine	Mercedes Benz V6, turbocharged, intercooled, low emission diesel engine
Gross power	290 kW (389 hp) @ 1,800 rpm	315 kW (422 hp) @ 1,800 rpm
Net Power	283 kW (380 hp) @ 1,800 rpm	308 kW (413 hp) @ 1,800 rpm
Gross torque	1,850 Nm (1,362 lbft) @ 1,300 rpm	2,000 Nm (1,473 lbft) @ 1,300 rpm
Net torque	1,824 Nm (1,343 lbft) @ 1,300 rpm	1,974 Nm (1,453 lbft) @ 1,300 rpm
Displacement	11,95 litres (730 cu.in)	11,95 litres (730 cu.in)
Fuel tank capacity	485 litres (128 US gal)	485 litres (128 US gal)
Auxilliary Brake	Automatic exhaust brake Engine Valve Brake (EVB)	Automatic exhaust brake Engine Valve Brake (EVB)
Certification	OM 501 LA.E2/1-00 meets Europe (EU) step2; OM 501 LA.E3A/1 meets Europe (EU) step 3	OM 501 LA.E2/1-00 meets Europe (EU) step2; OM 501 LA.E3A/1 meets Europe (EU) step 3
TRANSMISSION	Engine mounted, fully automatic Allison planetary transmission with six forward gears and one reverse gear. Hydrodynamic with lock-up in all gears.	Engine mounted, fully automatic Allison planetary transmission with six forward gears and one reverse gear. Hydrodynamic with lockup in all gears.
Torque Converter	4500R ORS	4500R ORS
Model	Electronic	Electronic
Control Type		
TRANSFER BOX	Remote mounted VGR 17100 Three in-line helical gears. Interaxle 33/67 proportional differential, Pneumatically lockable whilst stationary or on the move.	Remote mounted VGR 17100 Three in-line helical gears. Interaxle 33/67 proportional differential, Pneumatically lockable whilst stationary or on the move.
AXLES	High strength steel fabricated with spiral bevel type gears on the Controlled Traction differential and heavy duty outboard planetary gears. Bell 25T Dual circuit, full hydraulic actuation wet disc brakes on front and middle axles. 193 kN (43,388 lbf) Spring applied, air released driveline mounted disc. 440 kN (98,920 lbf) 575 kW (771 hp)	High strength steel fabricated with spiral bevel type gears on the Controlled Traction differential and heavy duty outboard planetary gears. Bell 25T Dual circuit, full hydraulic actuation wet disc brakes on front and middle axles. 218 kN (49,010 lbf) Spring applied, air released driveline mounted disc. 440 kN (98,920 lbf) 575 kW (771hp)
Model		
Brakes		
Max brake force		
Parking Brake		
Max brake force		
Total Retardation		
WHEELS	Earthmover 26.5R25	Earthmover 29.5R25
Tyre		
FRONT SUSPENSION	Semi-independent, leading A-frame supported by nitrogen/oil struts.	Semi-independent, leading A-frame supported by nitrogen/oil struts.
REAR SUSPENSION	Pivoting walking beams equalise the load on each axle with laminated suspension blocks. Each axle is coupled to the chassis by a Tri-Link system of four rubber-bushed links for ideal vertical movement and a transverse link for lateral restraint.	Pivoting walking beams equalise the load on each axle with laminated suspension blocks. Each axle is coupled to the chassis by a Tri-Link system of four rubber-bushed links for ideal vertical movement and a transverse link for lateral restraint.
HYDRAULIC SYSTEM	Variable displacement with load sensing system incorporating a ground driven emergency steering pump. 300 l/min (79,26 gal/min) 25 Mpa (3,626 psi) 10 micron	Variable displacement with load sensing system incorporating a ground driven emergency steering pump. 300 l/min (79,26 gal/min) 25 Mpa (3,626 psi) 10 micron
Flow		
Pressure		
Filter		
STEERING SYSTEM	Hydrostatically actuated by two double acting cylinders, with ground-driven emergency steering pump. 4.7 +-42°	Hydrostatically actuated by two double acting cylinders, with ground-driven emergency steering pump. 4.7 +-42°
Lock to lock turns		
Steering Angle		

	B35D	B40D
DUMPING SYSTEM	Two double-acting, single stage, dump cylinders	Two double-acting, single stage, dump cylinders
Raise Time	13 s	13 s
Lowering Time	7,6 s	7,6 s
Tipping Angle	70°	70°
PNEUMATIC SYSTEM	Air drier with heater and integral unloader valve, serving park brake and auxilliary functions	Air drier with heater and integral unloader valve, serving park brake and auxilliary functions
System Pressure	810 kPa (117 psi)	810 kPa (117 psi)
ELECTRICAL SYSTEM	24 V Two maintenance free permanently sealed	24 V Two maintenance free permanently sealed
Voltage		
Battery Type		
Battery Capacity	2 X 105 Ah	2 X 105 Ah
Alternator Rating	28 V 80 A	28 V 80 A
VEHICLE SPEEDS	1st 2nd 3rd 4th 5th 6th R 8 17 24 37 48 54 6,3 km/h 5 10.6 15 23 30 33.8 3.9 mph	1st 2nd 3rd 4th 5th 6th R 8 17 24 37 48 54 6,3 km/h 5 10.6 15 23 30 33.8 3.9 mph
OPERATING MASSES	UNLADEN LADEN Front 14,120 kg (31,129 lbs) 18,350 kg (40,455 lbs) Middle 7,060 kg (15,565 lbs) 21,195 kg (46,727 lbs) Rear 7,050 kg (15,543 lbs) 21,185 kg (46,705 lbs) Total 28,230 kg (62,236 lbs) 60,730 kg (133,887 lbs)	UNLADEN LADEN Front 14,650 kg (32,298 lbs) 19,587 kg (43,182 lbs) Middle 7,810 kg (17,218 lbs) 23,842 kg (52,563 lbs) Rear 7,390 kg (16,292 lbs) 23,422 kg (51,637 lbs) Total 29,850 kg (65,808 lbs) 66,851 kg (147,381 lbs)
GROUND PRESSURE <i>(At 15% sinkage of unloaded radius and specified weights)</i>	UNLADEN LADEN Front 108 kPa (15.7 psi) 303 kPa (44 psi) Middle 58 kPa (8.4 psi) 338 kPa (49 psi) Rear 58 kPa (8.4 psi) 338 kPa (49 psi)	UNLADEN LADEN Front 99 kPa (14 psi) 254 kPa (37 psi) Middle 49 kPa (7 psi) 316 kPa (46 psi) Rear 47 kPa (7 psi) 314 kPa (46 psi)
LOAD CAPACITY	Struck Capacity 15,9 m ³ (20.8 cu.yd) SAE 2:1 Capacity 20,1 m ³ (26.3 cu.yd) SAE 1:1 Capacity 24,6 m ³ (32.2 cu.yd) SAE 2:1 Capacity with Autogate 20,7 m ³ (27.1 cu.yd)	18 m ³ (23.5 cu.yd) 22,6 m ³ (29.6 cu.yd) 27,4 m ³ (35.8 cu.yd) 23,4 m ³ (30.6 cu.yd)
Rated Payload	32 500 kg (71.650 lbs)	37 000 kg (81.571 lbs)

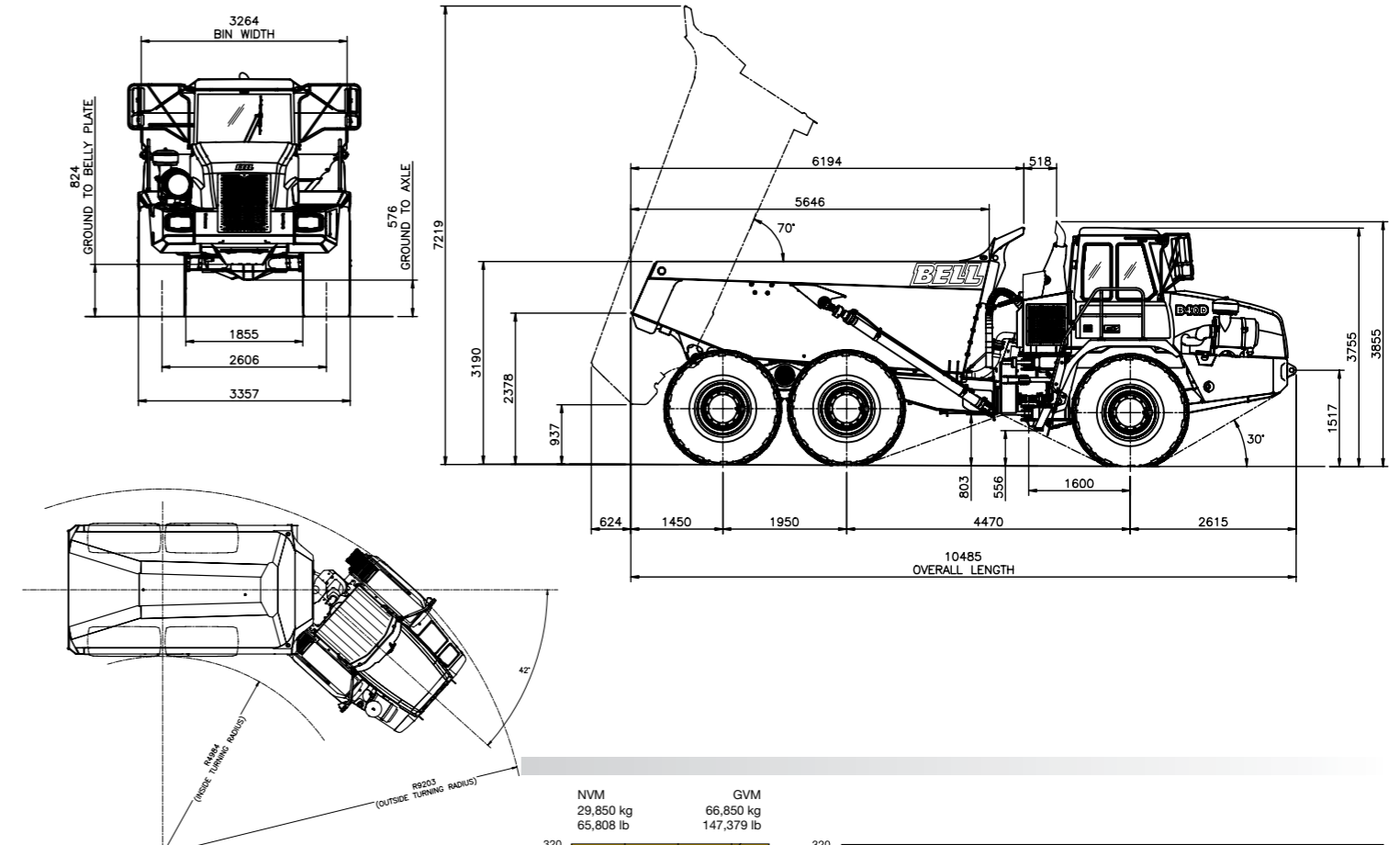
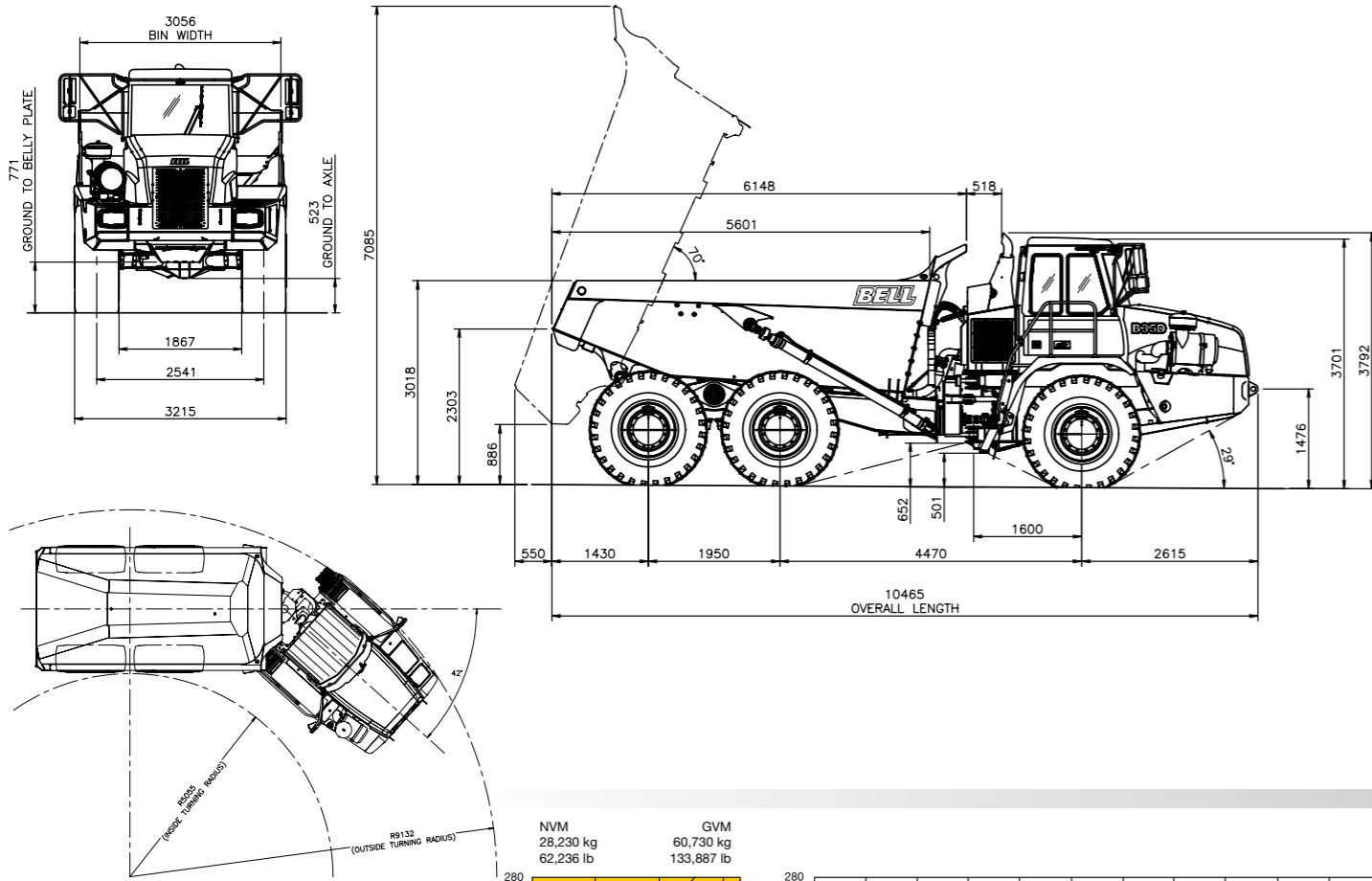

GRADEABILITY

1. Determine tractive resistance by finding intersection of vehicle mass line and grade line. NOTE: 2% typical rolling resistance is already assumed in chart and grade line.
2. From this intersection, move straight left across charts until line intersects rimpull curve.
3. Read down from this point to determine maximum speed attained at that tractive resistance.

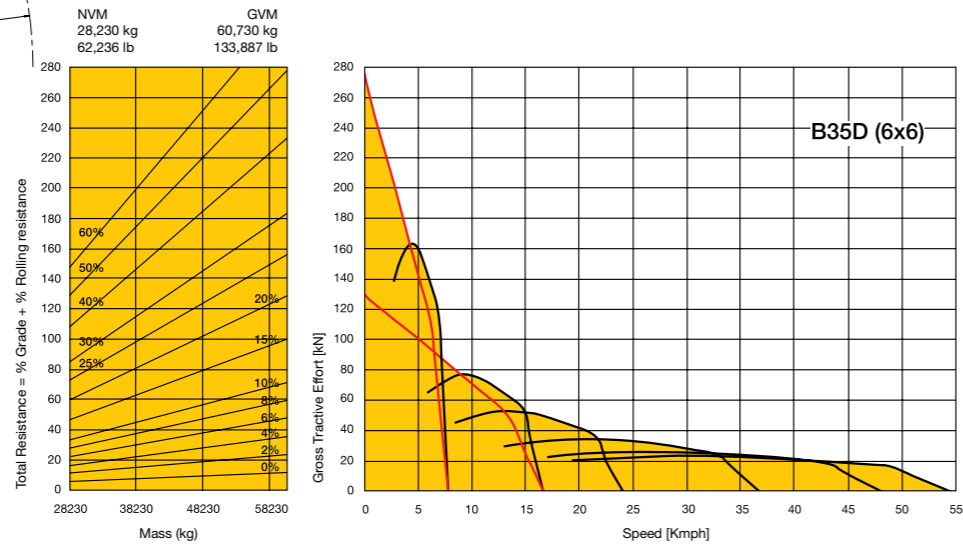

GRADEABILITY

1. Determine tractive resistance by finding intersection of vehicle mass line and grade line. NOTE: 2% typical rolling resistance is already assumed in chart and grade line.
2. From this intersection, move straight left across charts until line intersects rimpull curve.
3. Read down from this point to determine maximum speed attained at that tractive resistance.

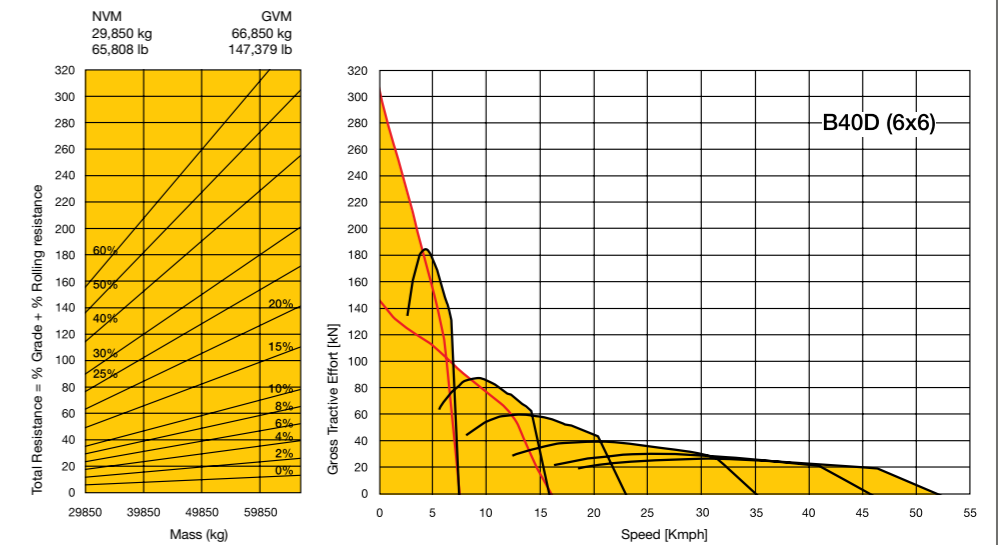

RETARDATION

1. Determine retardation force required by finding intersection of vehicle mass line.
2. From this intersection, move straight left across charts until line intersects the curve. NOTE: 2% typical rolling resistance is already assumed in chart.
3. Read down from this point to determine maximum speed.

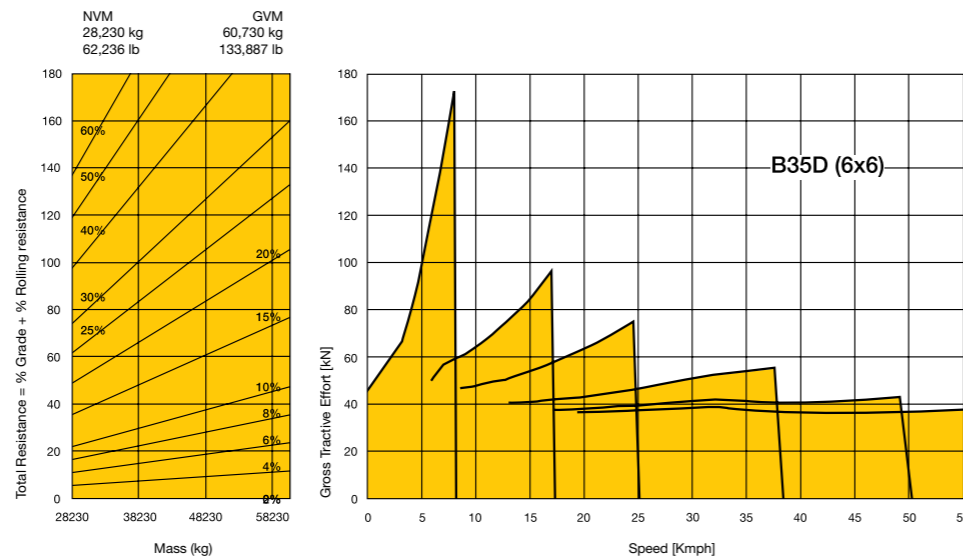

RETARDATION

1. Determine retardation force required by finding intersection of vehicle mass line.
2. From this intersection, move straight left across charts until line intersects the curve. NOTE: 2% typical rolling resistance is already assumed in chart.
3. Read down from this point to determine maximum speed.

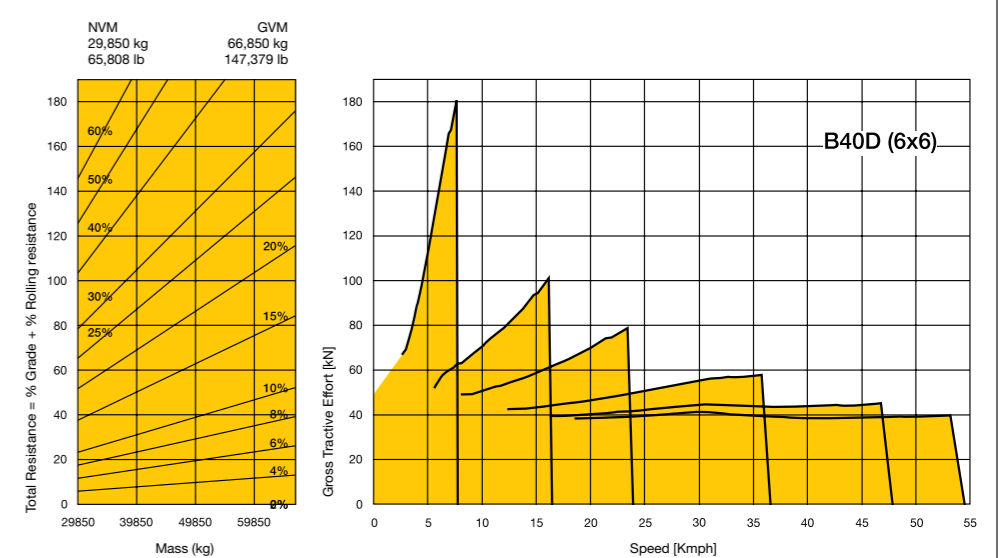

	B50D
ENGINE Configuration Aspiration Cooling system Gross power Net power Gross torque Net torque Displacement Fuel tank capacity Auxilliary Brake Certification Non Regulated Regulated	Mercedes Benz OM502LA V-8 Turbocharged and intercooled Liquid cooled with single pass radiator as well as charge air cooler 390 kW (523 hp) @ 1,800 rpm SAE J1349 382 kW (512 hp) @ 1,800 rpm 2,200 Nm (1,622 lbf) @ 1,200 rpm SAE J1349 2,147 Nm (1,584 lbf) @ 1,200 rpm 15,93 litres (730 cu.in) 640 litres (169 US gal) Automatic exhaust brake Engine Valve Brake (EVB) OM 502 LA.E2/1-00 meets Europe (EU) step2; OM 502 LA.E3A/1 meets Europe (EU) step 3
TRANSMISSION Layout Gear layout Gears Clutch type Control type Torque converter layout Vehicle speeds 1st 2nd 3rd 4th 5th 6th Reverse	Full automatic planetary transmission with integral retarder Engine mounted with rear output Constant meshing planetary gears, clutch operated 6 Forward, 1 Reverse Hydraulically operated multi-disc Electronic Hydrodynamic, with lockup in all gears 6,9 km/h (4,3 mph) 14,6 km/h (9,1 mph) 21,2 km/h (13,3 mph) 32,4 km/h (20,3 mph) 42,4 km/h (26,5 mph) 48,2 km/h (30,1 mph) 5,7 km/h (3,7 mph)
TRANSFER CASE Layout Output differential	VGR 17100 Three in-line helical gears Interaxle 33/67 proportional differential, pneumatically/ spring lockable whilst stationary or on the move.
AXLES Final drive type Housing type	High strength steel fabricated with spiral bevel type gears on the Controlled Traction differential and heavy duty outboard planetary gears. Outboard heavy duty planetary on all axles Steel fabricated
BRAKING SYSTEM SERVICE BRAKE Maximum brake force PARK & EMERGENCY Maximum brake force Maximum brake force	Dual circuit, full hydraulic oil immersed wet multidisc brakes on all three axles 399 kN (89,699 lbf) Spring applied, air released driveline mounted disc. 440 kN (98,920 lbf)-Static 105 kN (23,605 lbf)-Dynamic
RETARDATION SYSTEM ENGINE BRAKE Maximum retardation power TRANSMISSION RETARDER Total retardation power (excl. service brakes)	Automatic exhaust brake and Engine Valve Brake (EVB) 340 kW (456 hp) Integral hydrodynamic, output speed dependant, six selectable levels of retardation 550 kW (737 hp)
WHEELS Tyre size Type	875/65 R29 Radial Earthmover
SUSPENSION Front type Rear type	Semi-independent leading A-frame supported by nitrogen/oil struts Pivoting walking beams equalize the load on each axle with laminated suspension blocks. Each axle is coupled to the chassis by a Tri-Link system of three rubber-bushed links for ideal vertical movement and a transverse link for lateral restraint

	B50D															
HYDRAULIC SYSTEM Pump Type Application Flow Pressure Filter	Full load sensing system serving the prioritized steering, body tipping, suspension and brake functions. A ground-driven, load sensing emergency steering pump is integrated into the main system Variable displacement, load sensing piston Steering, tipping, hydraulic brake charging, suspension and cooling fan drive 350 l/min (92.5 US gal/min) 25 MPa (3,626 psi) 5 micron															
PNEUMATIC SYSTEM System pressure	Air drier with heater and integral unloader valve, serving park brake and auxiliary functions 750 kPa (109 psi)															
ELECTRICAL SYSTEM Voltage Battery type Battery capacity Alternator rating	24 V Two maintenance free permanently sealed 2 x 105 Ah (optional 2 extra batteries) 28 V 80 A															
STEERING SYSTEM Angle Lock to lock turns	Hydrostatically actuated by two double acting cylinders, with ground-driven emergency steering pump. +- 42° 4,2															
DUMPING SYSTEM Raise time Power down time Tipping angle	Two double-acting, single stage, dump cylinders 11.2 s (60° tip angle) 9.9 s (60° tip angle) 70° standard, or any lower angle programmable															
OPERATING MASSES Front Middle Rear Total	<table border="1"> <thead> <tr> <th></th> <th>UNLADEN</th> <th>LADEN</th> </tr> </thead> <tbody> <tr> <td>Front</td> <td>17,550 kg (38,691 lbs)</td> <td>23,440 kg (51,676 lbs)</td> </tr> <tr> <td>Middle</td> <td>8,500 kg (18,739 lbs)</td> <td>28,225 kg (62,292 lbs)</td> </tr> <tr> <td>Rear</td> <td>8,470 kg (18,673 lbs)</td> <td>28,255 kg (62,225 lbs)</td> </tr> <tr> <td>Total</td> <td>34,520 kg (76,104 lbs)</td> <td>79,920 kg (176,193 lbs)</td> </tr> </tbody> </table>		UNLADEN	LADEN	Front	17,550 kg (38,691 lbs)	23,440 kg (51,676 lbs)	Middle	8,500 kg (18,739 lbs)	28,225 kg (62,292 lbs)	Rear	8,470 kg (18,673 lbs)	28,255 kg (62,225 lbs)	Total	34,520 kg (76,104 lbs)	79,920 kg (176,193 lbs)
	UNLADEN	LADEN														
Front	17,550 kg (38,691 lbs)	23,440 kg (51,676 lbs)														
Middle	8,500 kg (18,739 lbs)	28,225 kg (62,292 lbs)														
Rear	8,470 kg (18,673 lbs)	28,255 kg (62,225 lbs)														
Total	34,520 kg (76,104 lbs)	79,920 kg (176,193 lbs)														
GROUND PRESSURE <i>(At 15% sinkage of unloaded radius and specified weights)</i> Front Middle Rear	<table border="1"> <thead> <tr> <th></th> <th>UNLADEN</th> <th>LADEN</th> </tr> </thead> <tbody> <tr> <td>Front</td> <td>100 kPa (14.6 psi)</td> <td>314 kPa (45psi)</td> </tr> <tr> <td>Middle</td> <td>53 kPa (7.7 psi)</td> <td>365 kPa (53 psi)</td> </tr> <tr> <td>Rear</td> <td>49 kPa (7.1 psi)</td> <td>365 kPa (53 psi)</td> </tr> </tbody> </table>		UNLADEN	LADEN	Front	100 kPa (14.6 psi)	314 kPa (45psi)	Middle	53 kPa (7.7 psi)	365 kPa (53 psi)	Rear	49 kPa (7.1 psi)	365 kPa (53 psi)			
	UNLADEN	LADEN														
Front	100 kPa (14.6 psi)	314 kPa (45psi)														
Middle	53 kPa (7.7 psi)	365 kPa (53 psi)														
Rear	49 kPa (7.1 psi)	365 kPa (53 psi)														
LOAD CAPACITY Struck Capacity SAE 2:1 Capacity SAE 1:1 Capacity SAE 2:1 Capacity with Autogate Rated Payload	21,6 m ³ (28.3 cu.yd) 27,5 m ³ (36.1 cu.yd) 34,5 m ³ (45.12 cu.yd) 28.7 m ³ (37.5 cu.yd) 45 400 kg (100.090 lbs)															

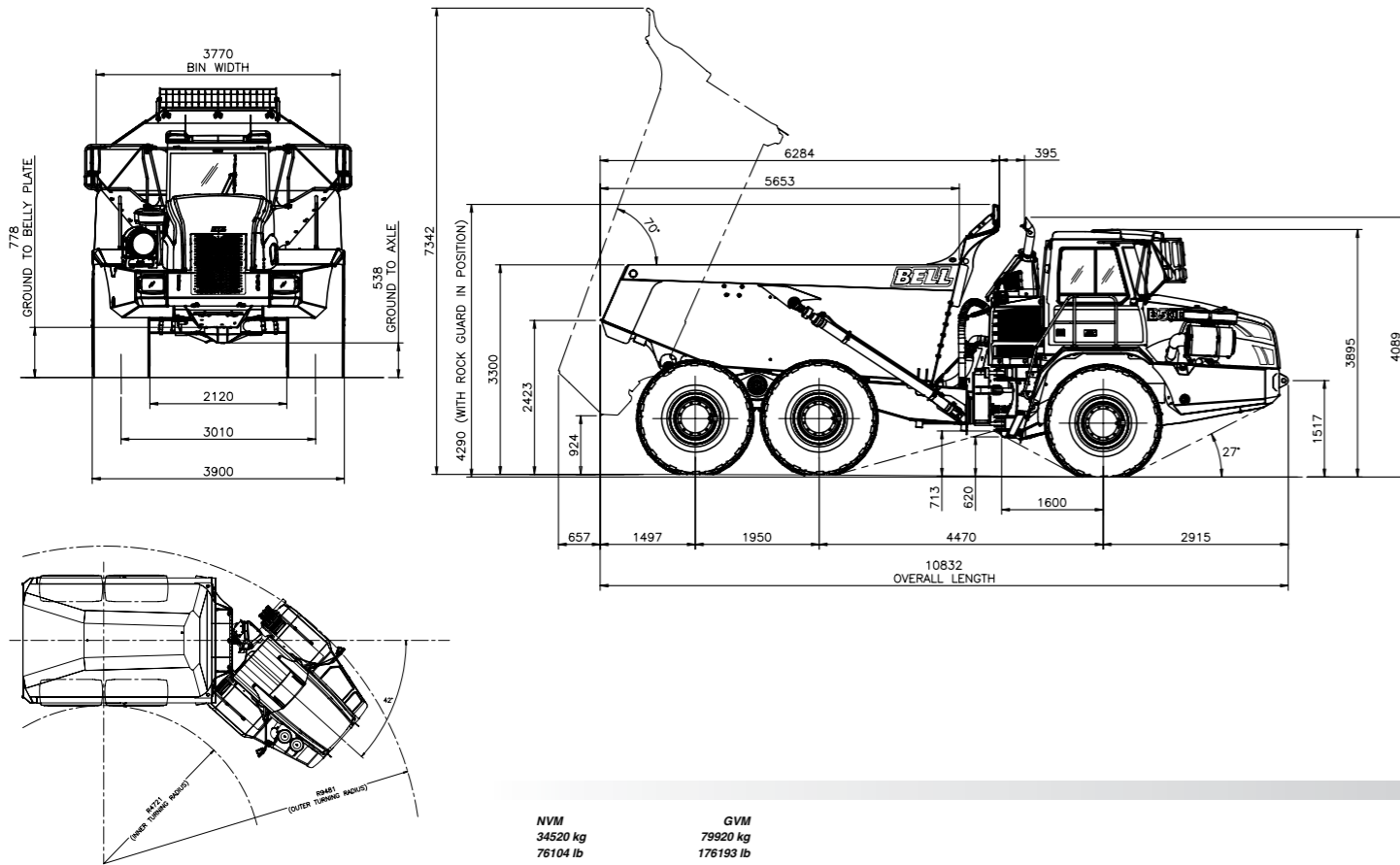

GRADEABILITY

- Determine tractive resistance by finding intersection of vehicle mass line and grade line. NOTE: 2% typical rolling resistance is already assumed in chart and grade line.
- From this intersection, move straight left across charts until line intersects rimpull curve.
- Read down from this point to determine maximum speed attained at that tractive resistance.

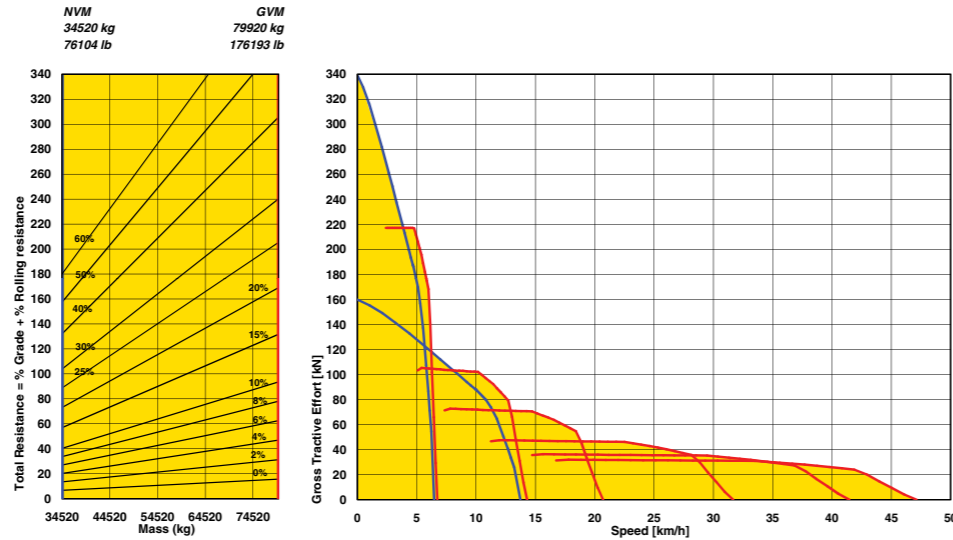

RETARDATION

- Determine retardation force required by finding intersection of vehicle mass line.
- From this intersection, move straight left across charts until line intersects the curve. NOTE: 2% typical rolling resistance is already assumed in chart.
- Read down from this point to determine maximum speed.

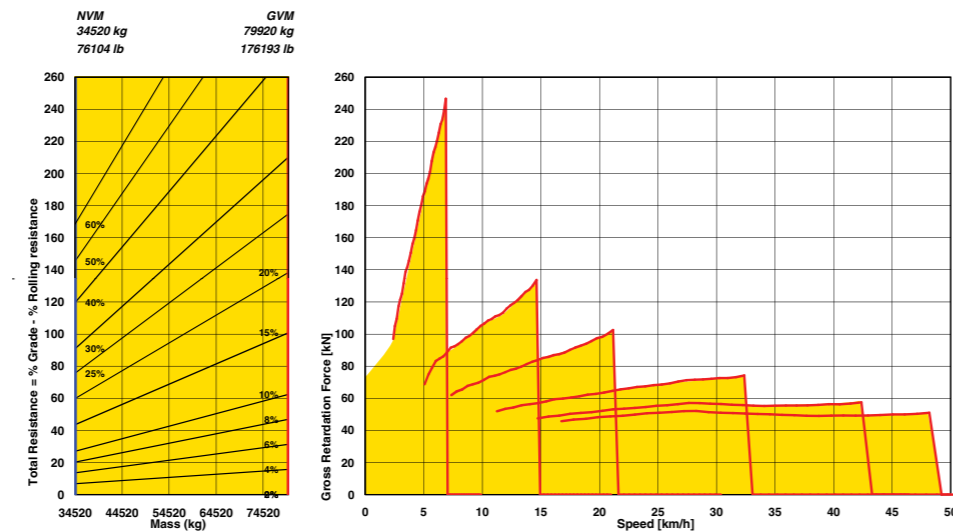



	B25D	B30D	B35D	B40D	B50D		B25D	B30D	B35D	B40D	B50D	
						● Standard ▲ Option						● Standard ▲ Option
Engine												
Wet-sleeve cylinder liners	●	●	●	●	●		●	●	●	●	●	
Engine valve brake and exhaust brake	●	●	●	●	●		●	●	●	●	●	
Dual-element air cleaner with dust ejector valve	●	●	●	●	●		●	●	●	●	●	
Precleaner	●	●	●	●	●		●	●	●	●	●	
Water separator	●	●	●	●	●		●	●	●	●	●	
Provision for fast fill	●	●	●	●	●		●	●	●	●	●	
Serpentine drive belt with automatic tensioner	●	●	●	●	●		▲	●	●	●	●	
Cooling												
Crankshaft-mounted viscous-drive fan	●	●	●	●	●		●	●	●	●	●	
Remote proportionally controlled hydraulic Fan drive	●	●	●	●	●		●	●	●	●	●	
Fan guard	●	●	●	●	●		●	●	●	●	●	
Pneumatic System												
Engine-mounted compressor	●	●	●	●	●		●	●	●	●	●	
Air drier with heater	●	●	●	●	●		●	●	●	●	●	
Integral unloader valve	●	●	●	●	●		●	●	●	●	●	
Electrical System												
Battery disconnect	●	●	●	●	●		●	●	●	●	●	
Drive lights	●	●	●	●	●		●	●	●	●	●	
Deluxe work lights	▲	▲	▲	▲	▲		▲	▲	▲	▲	▲	
Electric Hooter	●	●	●	●	●		●	●	●	●	●	
Air Horn	▲	▲	▲	▲	▲		▲	▲	▲	▲	▲	
Reverse alarm	●	●	●	●	●		●	●	●	●	●	
Rotating Beacon	▲	▲	▲	▲	▲		▲	▲	▲	▲	▲	
Pitch Roll Sensor	●	●	●	●	●		●	●	●	●	●	
Steering System												
Ground-driven secondary steering pump	●	●	●	●	●		●	●	●	●	●	
Cab												
ROPS/FOPS certification	●	●	●	●	●		●	●	●	●	●	
Tilt cab	●	●	●	●	●		●	●	●	●	●	
Gas strut-supported door	●	●	●	●	●		●	●	●	●	●	
I-Tip programmable dump-body tip settings	●	●	●	●	●		●	●	●	●	●	
Air conditioner	●	●	●	●	●		●	●	●	●	●	
Heater	●	●	●	●	●		●	●	●	●	●	
AM/FM radio/CD player	▲	▲	▲	▲	▲		▲	▲	▲	▲	▲	
Rear window guard	●	●	●	●	●		●	●	●	●	●	
Wiper/washer with intermittent control	●	●	●	●	●		●	●	●	●	●	
Tilt and telescoping steering wheel	●	●	●	●	●		●	●	●	●	●	
Centre-mount air-suspension seat	●	●	●	●	●		●	●	●	●	●	
Cab (continued)												
Retractable seat belt	●	●	●	●	●		●	●	●	●	●	
Foldaway trainer seat with retractable seat belt	●	●	●	●	●		●	●	●	●	●	
12-volt power outlet	●	●	●	●	●		●	●	●	●	●	
Cup holder	●	●	●	●	●		●	●	●	●	●	
Cooled/heated lunch box	●	●	●	●	●		●	●	●	●	●	
Ashtray	●	●	●	●	●		●	●	●	●	●	
Electric adjustable and heated mirrors	▲	●	●	●	●		▲	●	●	●	●	
Deluxe monitor:												
Analog speedometer / Fuel gauge /												
Transmission oil temperature gauge /												
Engine coolant temperature gauge /												
LED function/warning indicators and audible alarm /												
Transmission gear selection /												
Tachometer / Battery voltage / Hour meter /												
Odometer / Fuel consumption / Trip counter /												
Trip timer / Trip distance / Metric/English units /												
Service codes/diagnostics												
Backlit sealed switch module functions:												
Wiper control / Lights / Heated mirrors /												
Retarding aggressiveness / Controlled traction												
differentials (B35D/B40D/B50D) / Transfer case												
differential lock / Transmission gear hold /												
Dump-body tip limit / Automatic dump-body												
tip settings / Airconditioner/ Heater controls /												
Preselected Speed Control												
Dump Body												
Dump-body mechanical lock	●	●	●	●	●		●	●	●	●	●	
Body liner	▲	▲	▲	▲	▲		▲	▲	▲	▲	▲	
Tailgate	▲	▲	▲	▲	▲		▲	▲	▲	▲	▲	
Body heater	▲	▲	▲	▲	▲		▲	▲	▲	▲	▲	
Less dump body and cylinders	▲	▲	▲	▲	▲		▲	▲	▲	▲	▲	
Other												
23.5R25 radial earthmover tyres	●	●	●	●	●		●	●	●	●	●	
26.5R25 radial earthmover tyres	●	●	●	●	●		●	●	●	●	●	
29.5R25 radial earthmover tyres	●	●	●	●	●		●	●	●	●	●	
875/65R29 radial earthmover tyres	●	●	●	●	●		●	●	●	●	●	
Remote grease banks	●	●	●	●	●		●	●	●	●	●	
Automatic greasing	▲	▲	▲	▲	▲		▲	▲	▲	▲	▲	
Onboard Weighing	●	●	●	●	●		●	●	●	●	●	
Load lights	▲	▲	▲	▲	▲		▲	▲	▲	▲	▲	
Comfort Ride Suspension	▲	▲	▲	▲	▲		▲	▲	▲	▲	▲	
Reverse Camera	▲	▲	▲	▲	▲		▲	▲	▲	▲	▲	
Hand Rails	▲	▲	▲	▲	▲		▲	▲	▲	▲	▲	
Tyre Pressure Monitoring	▲	▲	▲	▲	▲		▲	▲	▲	▲	▲	

Notes:





BELL INTERNATIONAL : Tel: +27 (0) 35-907 9431

 Tel: +33 (0) 5 55 89 23 56

 Tel: +49 (0) 6631/ 91 13 - 0

 Tel: +34 91 879 60 19

 Tel: +27 (0) 11 928 9700

 Tel: +44 (0) 1283 712862

 Tel: +7 495 771 20 27

E-mail: sales@bellequipment.com • www.bellequipment.com

All dimensions are shown in millimetres, unless otherwise stated between brackets. Under our policy of continuous improvement, we reserve the right to change specifications and design without prior notice. Photographs featured in this brochure may include optional equipment.

Strong Reliable Machines
Strong Reliable Support

BELL