

# B40D 6x6 ARTICULATED DUMP TRUCK MK VII



Blu@dvantage™

- Gross Power: 335 kW (429 hp)
- Gross Torque: 2 200 Nm (1,622 lbft)
- Rated Payload: 37 000 kg (81,571 lbs)

**BELL**

# B40D 6x6 ARTICULATED DUMP TRUCK MKVII

## ENGINE

Mercedes Benz V6, turbo-charged, intercooled, low emission diesel engine  
**Gross power** 335 kW (429 hp) @ 1,800 rpm  
**Net Power** 325 kW (416 hp) @ 1,800 rpm  
**Torque** 2,200 Nm (1,622 lbft) @ 2,200 rpm  
**Displacement** 11,95 litres (730 cu.in)  
**Fuel tank capacity** 445 litres (118 US gal)  
**Auxiliary Brake** Automatic exhaust brake Engine Valve Brake (EVB)  
**AdBlue Tank Capacity Certification** 40 l (11 US gal) OM 501 LA meets Europe (EU) stage 3b emissions regulations

## TRANSMISSION

Fully automatic Allison planetary transmission  
**Layout** Engine mounted  
**Gear Layout** Constant meshing planetary gears, clutch operated  
**Gears** 6 Forward, 1 Reverse  
**Clutch type** Hydraulically operated multi-disc  
**Control type** Electronic  
**Torque Converter** Hydrodynamic with lock-up in all gears

## TRANSFER BOX

Remote mounted  
**Manufacturer** Bell  
**Model** 17100  
**Layout** Three in-line helical gears.  
**Output Differential** Interaxle 33/67 proportional differential. Pneumatically lockable on the move.

## AXLES

High strength steel fabricated with spiral bevel type gears on the Controlled Traction differential and heavy duty outboard planetary gears.  
**Model** Bell 25T

## BRAKING SYSTEM

**SERVICE BRAKE** Dual circuit, full hydraulic actuation wet disc brakes on front and middle axles.  
**Maximum brake force PARK & EMERGENCY** 218 kN (49,010 lbf)  
 Spring applied, air released driveline mounted disc.  
**Maximum brake force** 440 kN (98,920 lbf)



## AUXILIARY BRAKE

Automatic exhaust brake Engine Valve Brake (EVB)  
**Maximum retardation** Variable Adjustable Hydraulic retarder  
 575 kW (771 hp)

## WHEELS

**Tyre** Earthmover 29.5R25

## FRONT SUSPENSION

Semi-independent, leading A-frame supported by nitrogen/oil struts.

## REAR SUSPENSION

Pivoting walking beams equalise the load on each axle with laminated suspension blocks. Each axle is coupled to the chassis by a Tri-Link system of four rubber-bushed links for ideal vertical movement and a transverse link for lateral restraint.

## HYDRAULIC SYSTEM

Variable displacement with load sensing system incorporating a ground driven emergency steering pump.  
**Flow** 300 l/min (79,26 gal/min)  
**Pressure** 25 Mpa (3,626 psi)  
**Filter** 5 microns

## STEERING SYSTEM

Hydrostatically actuated by two double acting cylinders, with ground-driven emergency steering pump.  
**Lock to lock turns** 4.7  
**Steering Angle** 42°

## DUMPING SYSTEM

Two double-acting, single stage, dump cylinders  
**Raise Time** 13 s  
**Lowering Time** 7,6 s  
**Tipping Angle** 70°

## PNEUMATIC SYSTEM

Air drier with heater and integral unloader valve, serving park brake and auxiliary functions  
**System Pressure** 810 kPa (117 psi)

## ELECTRICAL SYSTEM

**Voltage** 24 V  
**Battery Type** Two maintenance free permanently sealed  
**Battery Capacity** 2 X 105 Ah  
**Alternator Rating** 28 V 80 A

## VEHICLE SPEEDS

1st	8 km/h
2nd	17 km/h
3rd	24 km/h
4th	37 km/h
5th	48 km/h
6th	54 km/h
R	6,3 km/h



# B40D 6x6 ARTICULATED DUMP TRUCK Mk VII

## LOAD CAPACITY & GROUND PRESSURE

WEIGHTS			GROUND PRESSURE		LOAD CAPACITY			OPTION WEIGHTS	
UNLADEN	kg	lbs	LADEN (No sinkage)	kPa	BODY	m <sup>3</sup>	cu.yd		kg
Front	14,650	32,298	Front	254	Struck Capacity	18,5	24,2	Bin liner	1,473
Middle	7,810	17,218	Middle	316	SAE 2:1 Capacity	23	30	Tailgate	858
Rear	7,390	16,292	Rear	314	SAE 1:1 Capacity	27,5	36	Extra wheelset	937
Total	29,850	65,808			SAE 2:1 Capacity with Autogate	24	31,4		
LADEN			LADEN (With sinkage)		Rated Payload	37 000 kg (81,571 lbs)			
Front	19,587	43,182	Front	144					
Middle	23,842	52,563	Middle	168					
Rear	23,422	51,637	Rear	168					
Total	66,851	147,381							

## GRADEABILITY/RIMPULL

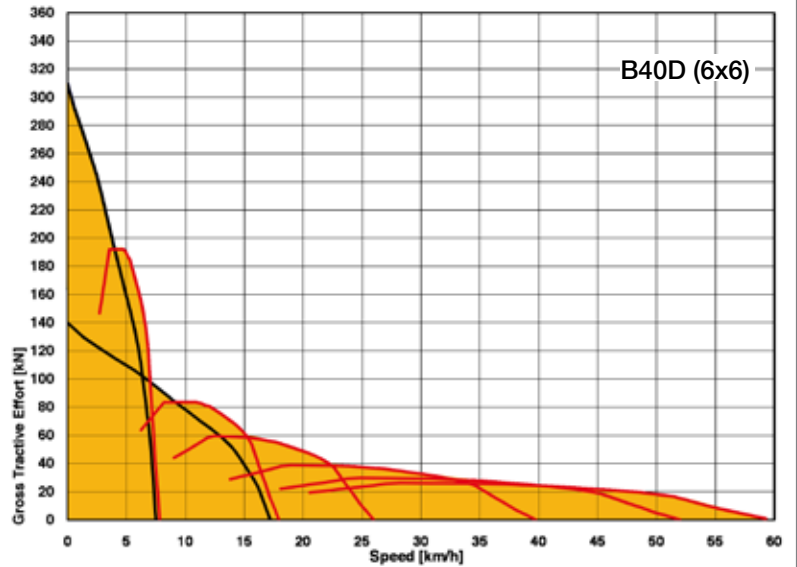
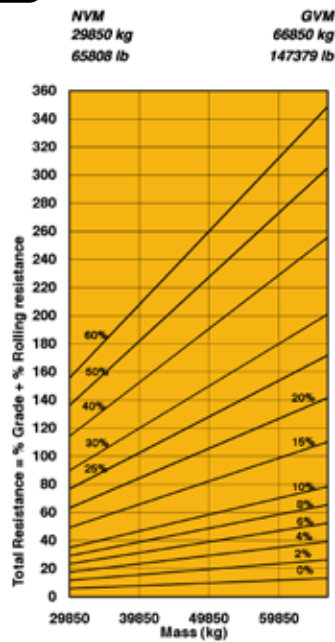

## RETARDATION

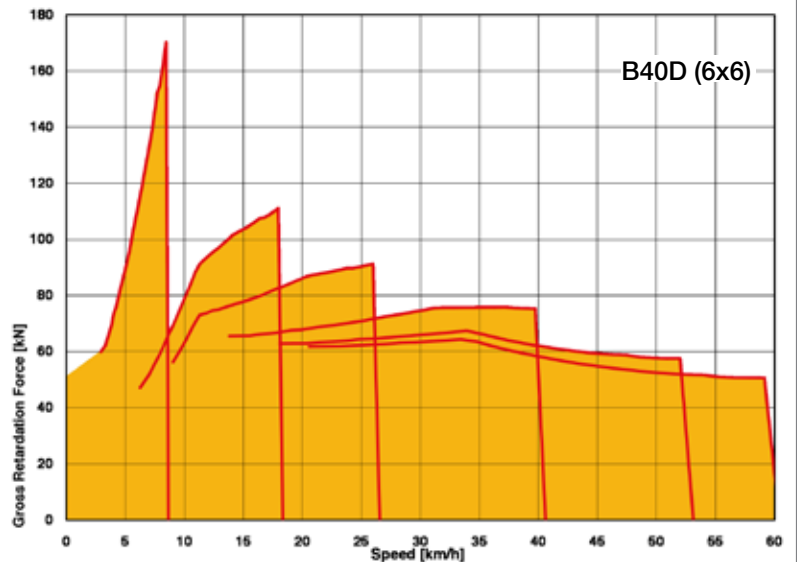
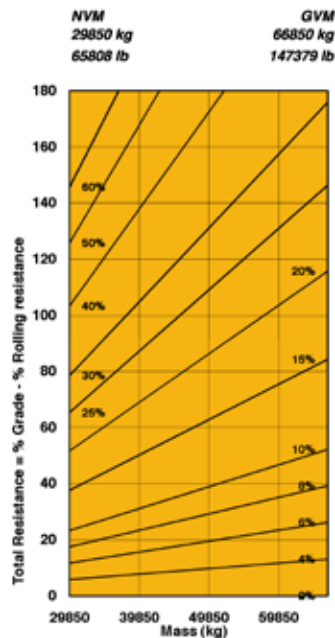

# B40D 6x6 ARTICULATED DUMP TRUCK Mk VII

## DIMENSIONS

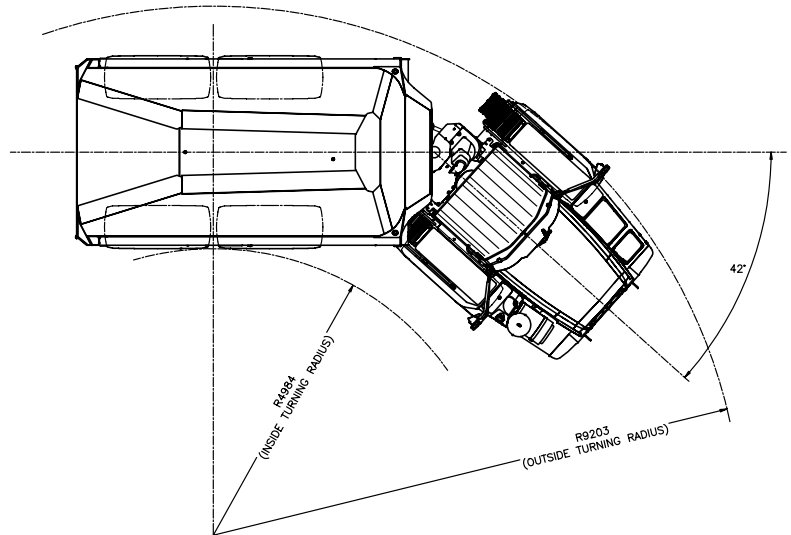
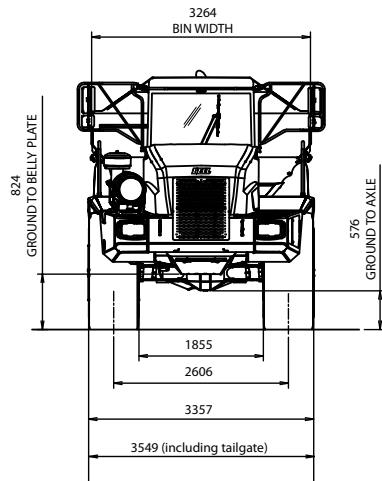
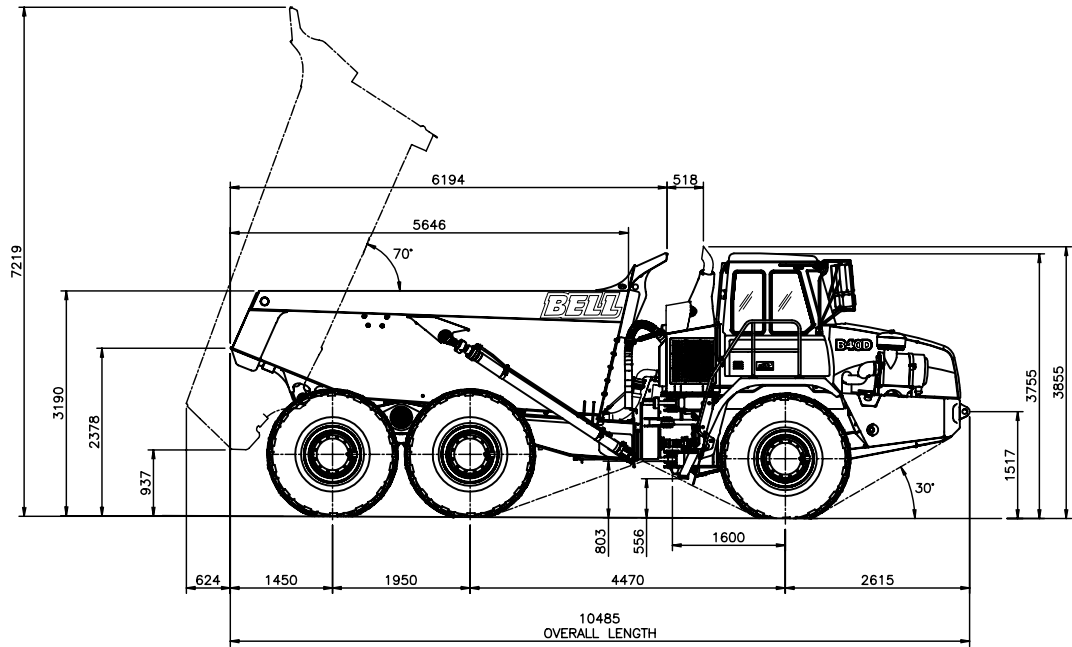

# B40D 6x6 ARTICULATED DUMP TRUCK MKVII

## AVAILABLE EQUIPMENT\*

### Cab

- ROPS/FOPS certification
- Protective rear window guard
- Tilt cab for service access
- Gas strut supported door
- Tinted safety glass
- Sliding windows
- Rear view mirrors- regular and wide angle
- Electrically adjustable rearview mirrors - one per side
- Sun visor
- Wiper/washer with intermittent control
- Tilt and telescoping steering wheel
- Adjustable, air suspension seat with retractable seat belt
- Fold-away trainer seat with retractable seat belt
- HVAC climate control system with filtered and ducted air
- Rotating beacon
- 12 V power outlet/12 V cigarette lighter
- Ash tray
- Drinks holder
- Cooled/heated lunch box
- I-Tip programmable bin tip
- Sound insulated to 76 dB(A) to ISO 6396
- Radio/CD/Tape
- Memory Module
- Air horn

### MDU Features

- Operator / Site selected speed control
- Tipping counter
- Trip timer
- Trip distance
- On Board Weigh System (OBW)
- Transmission gear selection
- Fuel Consumption
- Diagnostics
- Intermittent wiper timing control
- Speedo calibration for alternative tyre sizes
- Metric /Imperial unit selection
- Warning lights with audible buzzer

### Gauges

- Engine coolant temperature
- Engine oil pressure
- Transmission oil temperature
- Fuel
- Tachometer
- Battery voltage
- Hourmeter
- Odometer
- System air pressure

### Vehicle

- Ground driven emergency steering
- Bin safety prop
- Articulation lock
- Integral transmission output retarder with 6 settings

### Other

- (Factory or field installed)
- Groeneveld auto greasing system
  - Retractable sun visor
  - Exhaust body heating
  - Autogate
  - Body liners
  - Fleetmatic Satellite Monitoring System
  - Driver ID and immobiliser
  - Forward working lights
  - Artic reverse light
  - Fuel heater
  - External windshield visor
  - Headlight protection grills
  - Rear window wiper
  - Antenna mounting bracket
  - System for reverse camera
  - Wiggins quick fuelling system
  - Tyre pressure monitoring

\*standard specification for machines may vary according to region



# B40D 6x6 ARTICULATED DUMP TRUCK Mk VII

- The exclusive on-board weighing option presents the operator with real time information on the payload while the machine is being loaded. A 'limp home' mode can also be activated if the machine is significantly over-loaded.

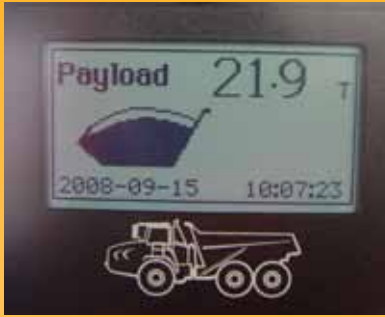

- The park brake automatically applies when neutral is selected and it is not possible to engage neutral at speed. Torque dependent park brake release (hill assist) ensures no roll back on slopes.



- The incorporation of a Pitch and Roll sensor in the vehicle allows the bin to not be operated if the truck is in an unsafe position.



- Full hand-rails kit can be installed to provide even more safety when performing engine checks.



- Keyless start, driver identity, and access codes ensures no unauthorized operation of your equipment.



- Both operator or site selectable maximum speed control allows the vehicle to automatically de-accelerate and apply the retarder to prevent onsite speeding.



- Reverse cameras are available for factory or on site fitment ensuring full view when reversing.



- Optional Tyre pressure - monitoring System ensures that the operator has real time information on all tyres pressure and temperature conditions.

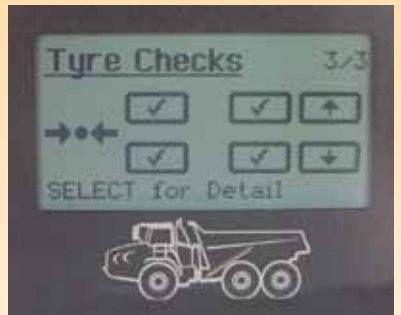

- The best in class retarder and engine braking automatically applies when the operator lifts his foot off the accelerator. Retarder aggressiveness can be simply adjusted on the sealed switch module ensuring maximum descent control for all conditions.

- All trucks can be set up to automatically sound the horn when starting or switching between forward and reverse.

BELL INTERNATIONAL: Tel: +27 (0) 35-907 9431

 Tel: +33 (0) 5 55 89 23 56

 Tel: +34 91 879 60 19

 Tel: +44 (0) 1283 712862

E-mail: [sales@bellequipment.com](mailto:sales@bellequipment.com)

 Tel: +49 (0) 6631 / 91 13 - 0

 Tel: +27 (0) 11-928-9700

 Tel: +7 495 647 20 90

• [www.bellequipment.com](http://www.bellequipment.com)

All dimensions are shown in millimetres, unless otherwise stated between brackets. Under our policy of continuous improvement, we reserve the right to change specifications and design without prior notice. Photographs featured in this brochure may include optional equipment.

**Strong Reliable Machines  
Strong Reliable Support**

# BELL