

Bergmann Dumper 3009 Three-way-tip

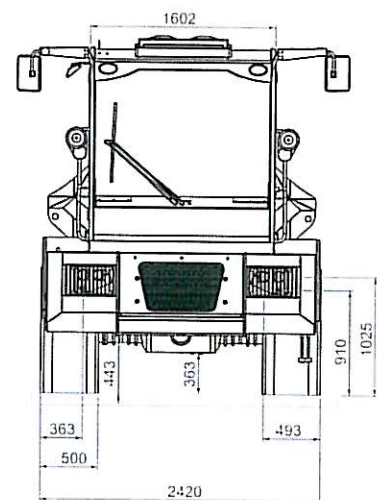

Strong arguments for your advantage

- ▶ high stability thanks to centre articulation
- ▶ swivelling operator's stand
- ▶ electrically hydraulic spring type park brake
- ▶ compact dimensions with low dead weight

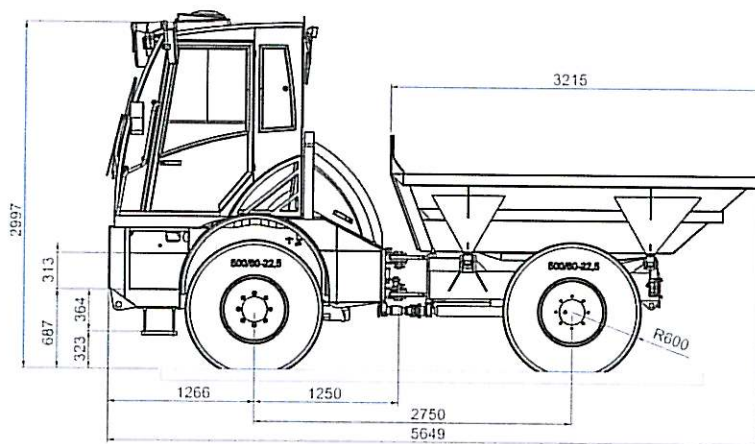



Bergmann Dumper 3009 Three-way-tip

Technical Data

Weight / Capacity

| | |
|-----------------|--|
| Payload | 9.000 kg |
| Unladen weight | 6.200 kg |
| Capacity struck | 2.800 l |
| Capacity heaped | 4,8 m ³ |
| Bucket system | Hydraulical three-way-tip; changeover from rear tip to three-way-tip simple by means of pins |

Dimensions

| | |
|------------------|----------|
| Cabin height | 2.997 mm |
| Total length | 5.650 mm |
| Total width | 2.420 mm |
| Ground clearance | 363 mm |

Transmission

Hydrostatic 4 wheel drive

| | | |
|---------|-----------|-----------|
| 1. gear | speed I: | 0-5 km/h |
| | Speed II: | 0-11 km/h |
| 2. gear | speed I: | 0-15 km/h |
| | Speed II: | 0-30 km/h |

Steering

Hydraulic articulation over priority valve
Articulation : 35° left & right

Axles / Brakes

Front axle rigid, rear axle oscillating stored +/- 12°, maintenance-free-oil-bath multi-disc brake with automatic adjustment in the front axle, hydraulically applicated locking brake acting over articulated shaft on front and rear axle.

Engine

4-Zylinder Kubota Diesel engine -water cooled-
power 74,0 KW at 2.600 rpm.

Tyres

Standard, all tyres 500/60-22,5

Engine hood

Fast and easy maintenance and service thanks to engine hood
To be opened in 2 sections

Quantity

fuel 120 L
hydraulic oil 80 L

Electrics

24V electric system with main switch, fuel and hour counter, control lamps for engine oil, park brake, direction indicator, battery charge control, hydraulic filter,

Standard equipment

Comfortable driver's cab with air-suspended driver's seat, swivelling operator's stand, lighting system according to German traffic regulations, bucket from abrasion proof fine grain steel, flashing yellow light, cigarette lighter, roller blind for front windscreen, device for radio, loudspeaker and antenna
EC declaration of conformity