

Bergmann Dumper 3012 Three-way-tip

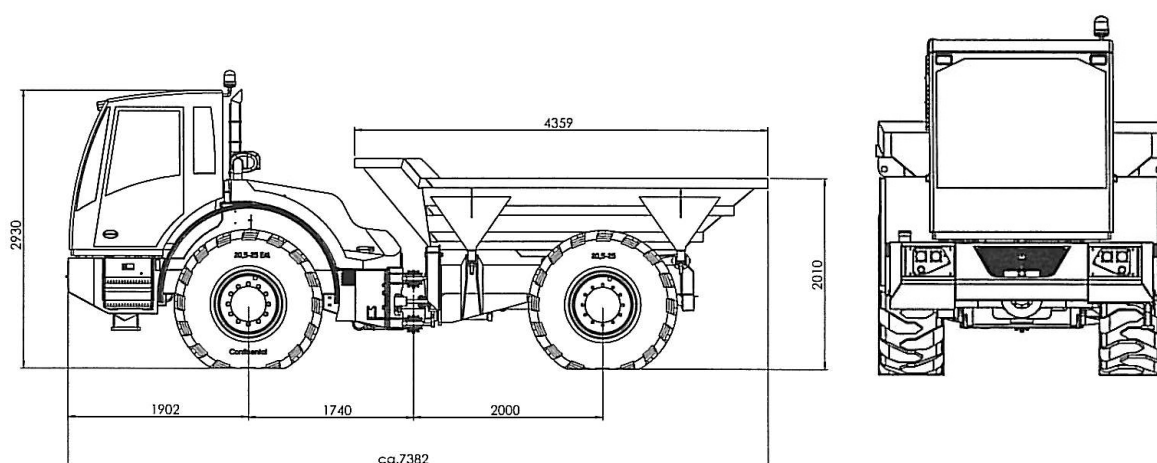

Strong arguments for your advantage

- ▶ high stability thanks to oscillating axle
- ▶ swivelling operator's stand
- ▶ electro hydraulic spring type cylinder park brake
- ▶ compact dimensions with low weight





Bergmann Dumper 3012 Three-way-tip

Technical Data

Weight / Bucket capacity	Payload	12.000 kg																	
	Unladen weight	10.020 kg																	
	Bucket capacity struck	4.400 l																	
	Bucket capacity heaped	7,5 m ³																	
	Bucket system	Hydraulical 3-way-tipper, change of sides by simply changing the socket pins																	
Dimensions	Height with cabine	2.900 mm																	
	Total length	7.380 mm																	
	Total width	2.500 mm																	
	Ground clearance	400 mm																	
Transmission	Load-depending shift – manually shiftably by hand and automatically, self-adjusting optimisation of traction force and speed, speed control stepless forward and backwards, ZF-Ergo-Power transmission																		
	<table border="1"> <tr> <td>1. gear</td> <td>F</td> <td>- 5 km/h</td> <td>2. gear</td> <td>F</td> <td>- 9 km/h</td> </tr> <tr> <td>3. gear</td> <td>F</td> <td>- 14 km/h</td> <td>4. gear</td> <td>F</td> <td>- 21 km/h</td> </tr> <tr> <td>5. gear</td> <td>F</td> <td>- 32 km/h</td> <td>6. gear</td> <td>F</td> <td>- 40 km/h</td> </tr> </table>	1. gear	F	- 5 km/h	2. gear	F	- 9 km/h	3. gear	F	- 14 km/h	4. gear	F	- 21 km/h	5. gear	F	- 32 km/h	6. gear	F	- 40 km/h
1. gear	F	- 5 km/h	2. gear	F	- 9 km/h														
3. gear	F	- 14 km/h	4. gear	F	- 21 km/h														
5. gear	F	- 32 km/h	6. gear	F	- 40 km/h														
Steering	Hydraulical articulated steering acting over priority valve																		
	articulation: 37° left & right																		
Axles / brakes	Front axle hydraulically shock absorbed, rear axle fix, maintenance-free-oil-bath multi-disc brake in the wheel hubs with self-locking differential with a locking value of 45 %, hydraulically applicated spring-type cylinder locking brake acting over articulated shaft on front and rear axle.																		
Engine	4-cylinder Deutz Diesel engine –water cooled– power 119 KW with 2.200 rpm																		
Tyres	Standard 20.5 R 25 double coin																		
Bonnet	Easy access to all maintenance and service points thanks to wide opening sectioned bonnet																		
Tank capacity	Fuel 190 L Hydraulic oil 81 L																		
Electrics	24 V electric system with main switch, fault finding modus, fuel and hour counter, control lamps for engine oil, parking brake, driving direction display, battery charging control, hydraulic filter, display for drive position																		
Standard equipment	Comfortable driver's cab with air-suspended driver's seat, swivelling operator's stand, lighting system according to German traffic regulations, bucket from abrasion proof fine grain steel, flashing yellow light, cigarette lighter, roller blind for front windscreen, device for radio, loudspeaker and antenna EC declaration of conformity																		