

Bergmann Dumper

1200 Loader Dumper



Strong arguments for your advantage

- ▶ high economic efficiency due to the number of attachments
- ▶ compact dimensions
- ▶ high loads with small net weight
- ▶ transport on tandem trailer
- ▶ type test approval by TBG

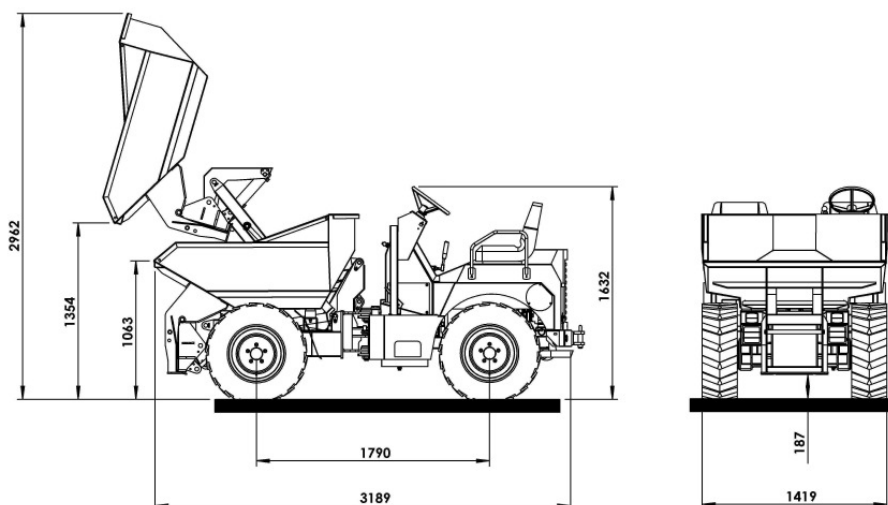



Bergmann Dumper 1200 Loader Dumper

Technical Data

Weight/ bucket capacity	Payload	2.000 kg
	Unladen weight	1.620 kg
	Struck level	900 L
	Heaped	1,3 m ³
	Bucket system	Hydraulic front high tip
Dimensions	Total height with protection bar	2.100 mm
	Total height without protection bar	1.630 mm
	Total length	3.190 mm
	Total width	1.420 mm
	Ground clearance	187 mm
Transmission	Hydrostatic 4-wheel-drive over 4 wheel engines Twin-lock control 0-23 km/h multistage	
Steering	Hydraulic articulated steering with emergency steering Steering angle 35° to each side	
Axles / Brakes	Front axle rigid, rear axle oscillating stored +/- 12°, maintenance-free-oil-bath multi-disc brake with automatic adjustment in the wheel engines of the front axle, hydraulically applied locking brake acting on front wheels.	
Engine	3 cylinder Kubota Diesel engine –water cooled- Output power 18,5 KW at 2.800 rpm.	
Tyres	Standard, 10,0/75-15.3 AS Profil	
Tank capacity	Fuel 25 L Hydraulic oil 32 L	
Electrics	12V electrical installation with main switch, control panel for engine water temperature, fuel and service hour meter, control lamps for motor oil; park brake, direction indicator, battery charging control, horn	
Standard Equipment	Driver's seat adjustable, tow-bar coupling, lighting system according to German traffic regulations, bucket from abrasion-proof fine-grain steel, differential lock, joystick control with integrated driving switch, patented rapid changing system for bucket and attachments EC type test approval, EC declaration of conformity, operator's manual / spare parts list	
Attachments	Palett forks, shovel, dung fork, sweeper, snow sweeper, saltceller, special buckets, plank, water tank with watering mechanism, paving stone transport pincers, Further attachments on enquiry	