

Bergmann Dumper 2030 swivel tip

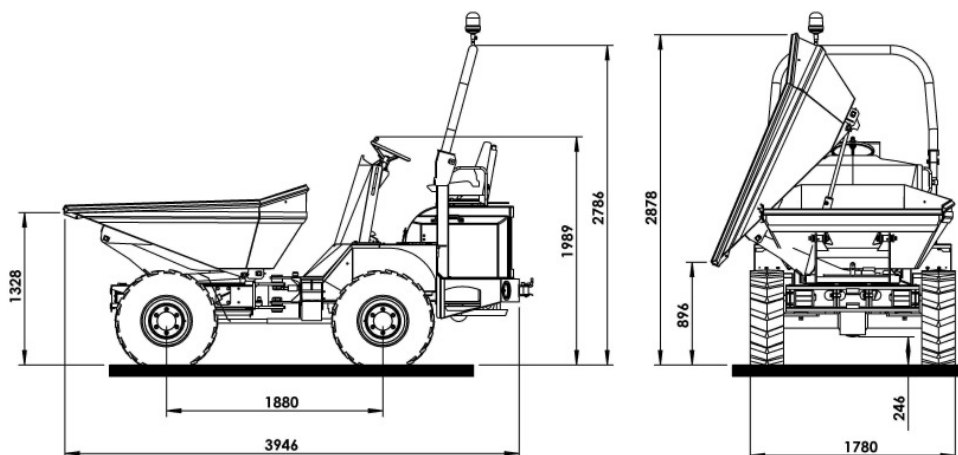

Strong arguments for
your advantage

- ▶ high stability by
oscillating axle
- ▶ hydraulic park brake
- ▶ instrument board
lowerable and lockable
- ▶ type test approval by
TBG





Bergmann Dumper 2030 swivel tip

Technical Data

Weight/ bucket capacity	Payload	3.000 kg
	Unladen weight	2.340 kg
	Struck level	1.150 L
	Heaped	1,8 m ³
	Bucket system	hydraulically swivelling and tipping bucket by 180°
Dimensions	Total height with protection bar	2.780 mm
	Total height without protection bar	1.990 mm
	Total length	3.940 mm
	Total width	1.780 mm
	Ground clearance	246 mm
Transmission	Hydrostatic 4-wheel-drive	
	speed I:	0-10 km/h
	speed II:	0-23 km/h
Steering	Hydraulic articulated steering acting over priority flow	
	Steering angle 40° to each side	
Axles / Brakes	Front axle rigid, rear axle oscillating stored +/- 12°, maintenance-free-oil-bath multi-disc brake with automatic adjustment in the front axle, hydraulically applied locking brake acting over articulated shaft on front and rear axle.	
Engine	3 cylinder Kubota Diesel engine –water cooled– Output power 25,5 KW at 2.800 rpm.	
Tyres	Standard, 11,5/80-15.3 AS Profil	
Tank capacity	Fuel 50 L Hydraulic oil 40 L	
Electrics	12V electrical installation with main switch, control panel for engine water temperature, fuel and service hour meter, control lamps for motor oil; park brake, direction indicator, battery charging control, hydraulic filter, display for drive position	
Standard Equipment	Hydro sprung seat adjustable and collapsible, instrument panel lowerable and lockable with ignition key, tow-bar coupling, lighting system according to German traffic regulations, bucket from abrasion-proof fine-grain steel, EC type test approval, EC declaration of conformity, operator's manual / spare parts list	