

Bergmann Dumper

2035 putting down dumper



Strong arguments for your advantage

- ▶ high stability by oscillating axle
- ▶ hydraulic park brake
- ▶ instrument board lowerable and lockable
- ▶ bucket hydraulically lowerable
- ▶ type test approval by TBG

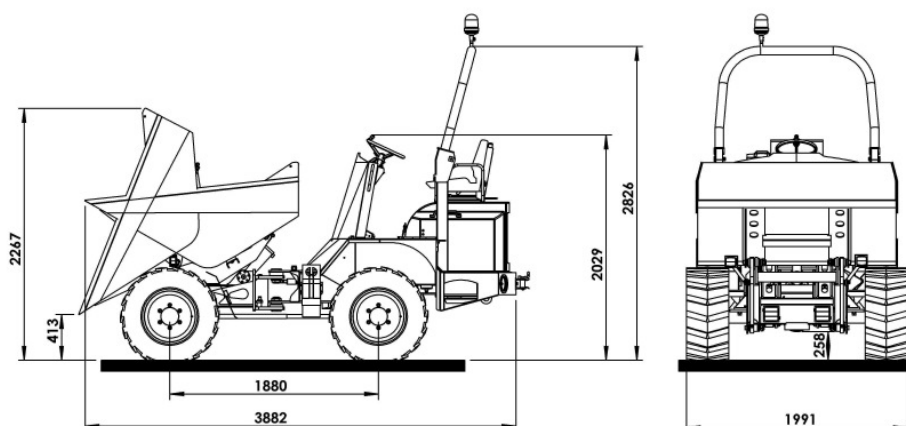



Bergmann Dumper 2035 putting down dumper

Technical Data

Weight/ bucket capacity	Payload	3.500 kg
	Unladen weight	2.850 kg
	Struck level	1.460 L
	Heaped	2.1 m ³
	Bucket system	Hydrostatic front tip with lowering system
Dimensions	Total height with protection bar	2.820 mm
	Total height without protection bar	2.030 mm
	Total length	3.880 mm
	Total width	1.990 mm
	Ground clearance	258 mm
Transmission	Hydrostatic 4-wheel-drive with automotive control speed I: 0-10 km/h speed II: 0-24 km/h	
Steering	Hydraulic articulated steering acting over priority flow Steering angle 40° to each side	
Axles / Brakes	Front axle rigid, rear axle oscillating stored +/- 12°, maintenance-free-oil-bath multi-disc brake with automatic adjustment in the front axle, hydraulically applied locking brake acting over articulated shaft on front and rear axle.	
Engine	4 cylinder Kubota Diesel engine –water cooled– Output power 34 KW at 2.800 rpm.	
Tyres	Standard, 15,5/55 R 17 AS-Profil	
Tank capacity	Fuel 50 L Hydraulic oil 40 L	
Electrics	12V electrical installation with main switch, control panel for engine water temperature, fuel and service hour meter, control lamps for motor oil; park brake, direction indicator, battery charging control, hydraulic filter, display for drive position	
Standard Equipment	Hydro sprung seat adjustable and collapsible, instrument panel lowerable and lockable with ignition key, tow-bar coupling, lighting system according to German traffic regulations, bucket from abrasion-proof fine-grain steel, lowering bucket mechanism, EC type test approval, EC declaration of conformity, operator's manual / spare parts list	