

Bergmann Dumper 2050 Three way

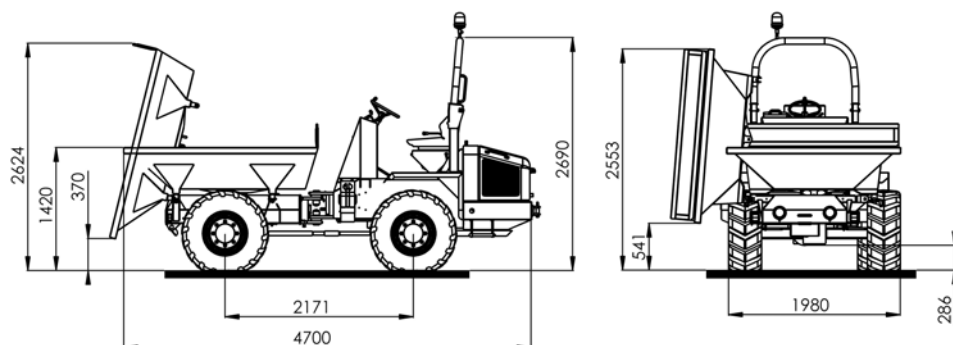

Strong arguments for your advantage

- ▶ high stability by oscillating axle
- ▶ hydraulic park brake
- ▶ instrument board lowerable and lockable
- ▶ type test approval by TBG





Bergmann Dumper 2050 three-way-tipping

Technical Data

Weight/ bucket capacity	Payload	5.000 kg
	Unladen weight	3.440 kg
	Struck level	1.600 L
	Heaped	2,8 m ³
	Bucket system	change of sides by simple changing of the plug bolt
Dimensions	Total height	2.690 mm
	Total length	4.700 mm
	Total width	1.980 mm
	Ground clearance	286 mm
Transmission	Hydrostatic 4-wheel-drive with automotive control	
	speed I:	0-10 km/h
	speed II:	0-25 km/h
Steering	Hydraulic articulated steering acting over priority flow Steering angle 40° to each side	
Axles / Brakes	Front axle rigid, rear axle oscillating stored +/- 12°, maintenance-free-oil-bath multi-disc brake with automatic adjustment in the front axle, hydraulically applied locking brake acting over articulated shaft on front and rear axle.	
Engine	4 cylinder Kubota Diesel engine –water cooled- Output power 50,5 KW at 2.600 rpm.	
Tyres	Standard, 365/70-18 AS Profil	
Tank capacity	Fuel	45 L
	Hydraulic oil	40 L
Electrics	12V electrical installation with main switch, control panel for engine water temperature, fuel and service hour meter, control lamps for motor oil; park brake, direction indicator, battery charging control, hydraulic filter, display for drive position	
Standard Equipment	Hydro sprung seat adjustable and collapsible, instrument panel lowerable and lockable with ignition key, tow-bar coupling, lighting system according to German traffic regulations, bucket from abrasion-proof fine-grain steel, EC type test approval, EC declaration of conformity, operator's manual / spare parts list	