

Bergmann Dumper 2050 swivel tip

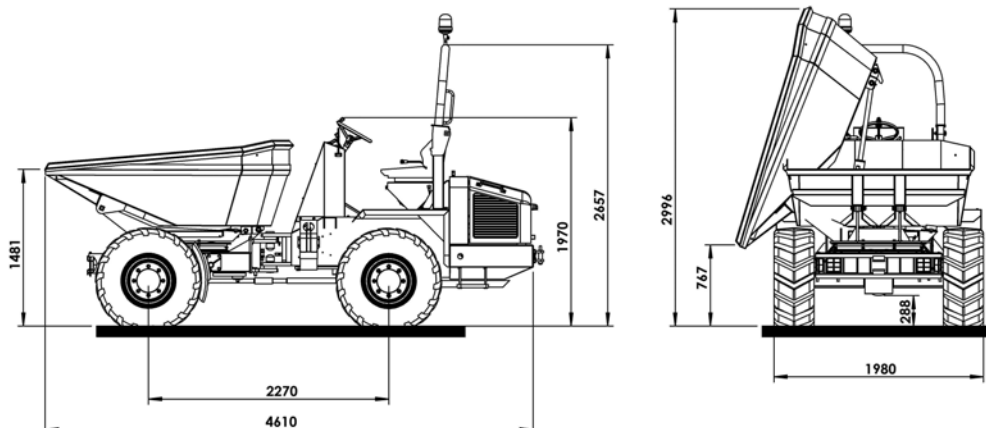

Strong arguments for your advantage

- ▶ high stability by oscillating axle
- ▶ hydraulic park brake
- ▶ instrument board lowerable and lockable
- ▶ type test approval by TBG





Bergmann Dumper 2050 swivel tip

Technical Data

Weight/ bucket capacity	Payload	5.000 kg
	Unladen weight	3.420 kg
	Struck level	1.900 L
	Heaped	2,8 m ³
	Bucket system	hydraulically swivelling and tipping bucket by 180°
Dimensions	Total height with protection bar	2.650 mm
	Total height without protection bar	1.970 mm
	Total length	4.610 mm
	Total width	1.980 mm
	Ground clearance	288 mm
Transmission	Hydrostatic 4-wheel-drive with automotive control speed I: 0-12 km/h speed II: 0-25 km/h	
Steering	Hydraulic articulated steering acting over priority flow Steering angle 40° to each side	
Axles / Brakes	Front axle rigid, rear axle oscillating stored +/- 12°, maintenance-free-oil-bath multi-disc brake with automatic adjustment in the front axle, hydraulically applied locking brake acting over articulated shaft on front and rear axle.	
Engine	4 cylinder Kubota Diesel engine –water cooled– Output power 50,5 KW at 2.600 rpm.	
Tyres	Standard, 365/70-18 AS Profil	
Tank capacity	Fuel 45 L Hydraulic oil 40 L	
Electrics	12V electrical installation with main switch, control panel for engine water temperature, fuel and service hour meter, control lamps for motor oil; park brake, direction indicator, battery charging control, hydraulic filter, display for drive position	
Standard Equipment	Hydro sprung seat adjustable and collapsible, instrument panel lowerable and lockable with ignition key, tow-bar coupling, lighting system according to German traffic regulations, bucket from abrasion-proof fine-grain steel, EC type test approval, EC declaration of conformity, operator's manual / spare parts list	