

STANDARD EQUIPMENT

GENERAL

Access ladders
Air conditioning
Air cleaner protection
All-hydraulic braking
Automatic lubrication system
Battery isolation switch
Body down indicator, mechanical
Body prop cable
Centralized service panel
Continuous heated body
Electric horn, quad
Electronic hoist control
Electric start
Engine access ladders (2)
Fan guard
Fuel gauge on tank
Ground level engine shutdown switch
Guard rails around platform
HAULTRONIC II load weighing system

CAB

Acoustical lining
Air filtration/replaceable element
Air suspension seat, 6-position
Ash tray
Auxiliary outlet, 12-volt
Cab interior light
Cigar lighter
Door locks
Engine starter/shutdown switch
Full trainer seat
Integral ROPS/FOPS cab
ISO driver envelope

GAUGES AND INDICATORS

CONTRONIC II monitoring and alarm system, multi-function indicator lights:
Air filter restriction
Alternator
Body up indicator
Brake supply pressure
Central warning
Engine oil pressure
Engine coolant temperature
High beam indicator
Hoist filter restriction
Hoist oil temperature
Hoist supply pressure
Parking brake applied
Steering filter restriction
Steering oil temperature
Traction blower failure
Traction system failure
Turn signal/hazard

MACHINE LIGHTS

Back-up lights, (2)
Clearance lights, LED (4)
Control cabinet lights, (3)
Dual combination stop and tail lights, LED (2)
Dynamic retarding light, (1)
Engine compartment lights, (2)
HID Headlights, (4)
Payload monitoring lights, (6)
Rear axle light, (1)
Turn signals and four-way flashers (LED)

HID headlights
Hoist kickout
Ladder lights
Mirror, right and left
Mud flaps
NEOCON suspension struts
On board load box
Operator arm guard
Propulsion interlock, body up
Radiator grille guard
Retard speed control
Retarder grid package, 18-element, 3-step
Reverse alarm
Rock ejector bars
Supplementary steering system accumulator
Tires, 37.00R57(**)E4
Tow hooks, front
Two-speed overspeed setting

OPTIONAL EQUIPMENT

Ansul centralized fire extinguishing system (12 nozzle)
Auxiliary dump
Auxiliary steer
Body liners (400BHN) (12" total)
Circuit board with breakers
Engine coolant and oil heater (220 V AC)
Engine, Cummins K series
Fast fueling system, on tank
Keyless starter switch
Mufflers
Oil sampling connections
Radio
Radio with CD player
Retarding-7step extended range
Rimex MES rims
Thermatic fan
Trolley assist configuration

Standard and optional equipment may vary from country to country. Special options provided on request. All specifications are subject to change without notice.

Load and hold switch
Modular heater/AC evaporator
Modular instrumentation
Operator & trainer seat belts
Roll down windows
Rubber floor mat
Safety glass
Sun visor
Tilt/telescopic steering
Tinted glass all windows
Windshield washer
Windshield wiper

Note: Dimensions shown are for empty machine with 37.00R57(**)E4 tires.

unit:mm (ft in)

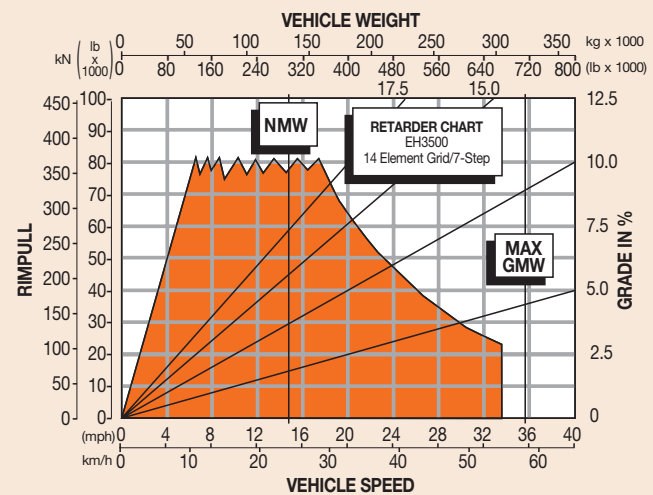
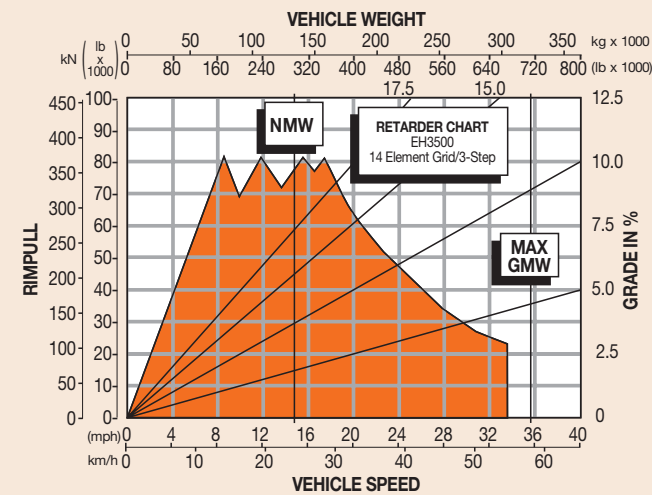
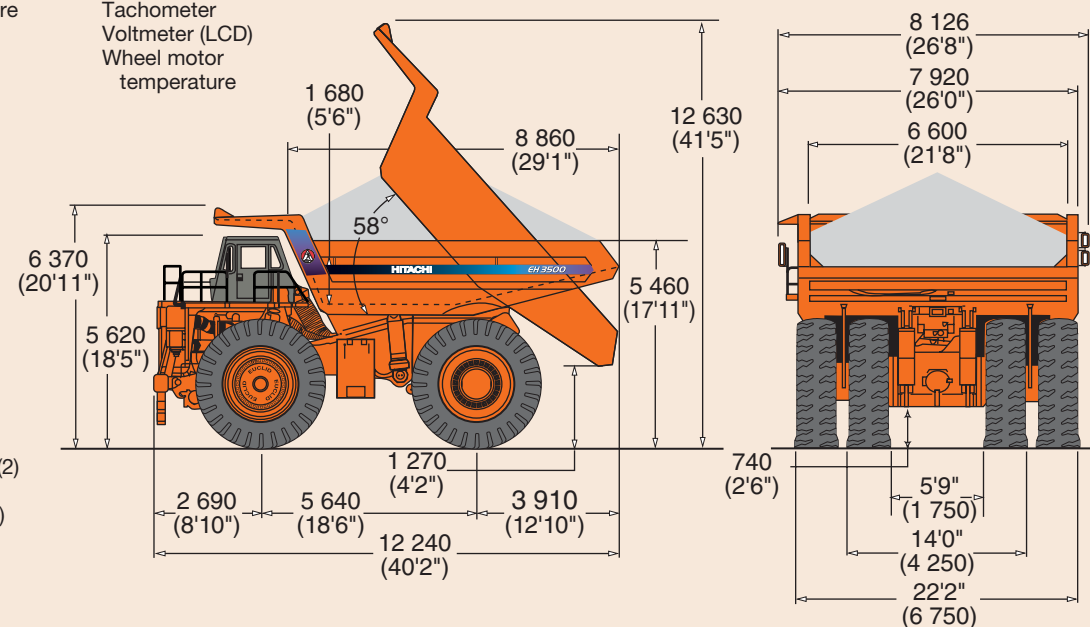
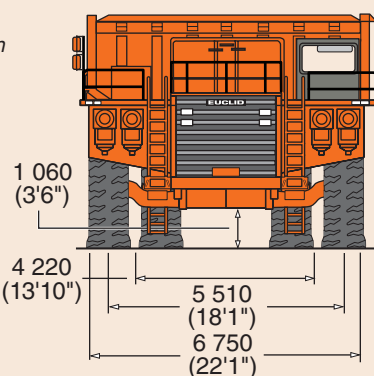

INSTRUCTIONS:

Diagonal lines represent total resistance (Grade % plus rolling resistance %). Charts based on 0% rolling resistance, standard power of engine, standard tires and gearing unless otherwise stated.

1. Find the total resistance on diagonal lines on right-hand border of rimpull or retarder chart.
2. Follow the diagonal line downward and intersect the NMW or GMW weight line.
3. From intersection, read horizontally right or left to intersect the rimpull or retarder curve.
4. Read down for machine speed.

Hitachi Construction Machinery Co., Ltd.

Head Office: 5-1 Koraku 2-chome, Bunkyo-ku, Tokyo 112-8563, Japan
Telephone : 81-3-3830-8050
Facsimile : 81-3-3830-8204
URL : www.hitachi-c-m.com

KR-E125Q

05.05(KA/KA,FT₃)

Printed in Japan

EH 3500

Nominal Payload with Standard Equipment
171 tonnes (189 tons)

Maximum GMW with Standard Tires
324 324 kg (715 000 lb)

Engine
Detroit Diesel 12V Series 4000
Rated Power 1 510 kW (2 025 HP)



Specifications: EH3500



ENGINE

Model	Detroit Diesel 12V Series 4000
Type	4 Cycle
Aspiration	Turbocharged
Rated Power @1 900 min ⁻¹ (rpm)	
Gross power (SAE J1995)	1 510 kW (2 025 HP)
Net power (SAE J1349)	1 414 kW (1 896 HP)
Maximum Torque @1 500 min ⁻¹ (rpm) (SAE J1995)	8 200 N·m (836 kgf·m 6 047 lbf·ft)
No. Cylinders	12
Bore & Stroke	165 x 190 mm (6.50 in x 7.48 in)
Displacement	48.8 L (2 975 in ³)
Starting	Electric



ELECTRIC DRIVE

Controls

General Electric Statex III System with latest fuel enhancement feature and wet weather retarding.

Alternator

General Electric Model GTA 22M. Direct mounted to engine.

Wheel Motors

General Electric Model 788FS motors complete with planetary assembly in each rear wheel.

Planetary Ratio	26.83:1
Maximum Speed	55.7 km/h (34.6 mph)

Note:

Wheel motor and dynamic retarding configuration subject to GE approval for a given application.



TIRES

Standard - Front and Rear 37.00R57(**)E4 Radials	Rim Width 686 mm (27.0 in)
Optional - Front and Rear 36.00R51(**)E4 Radials	660 mm (26.0 in)

Certain job conditions may require higher TKPH (TMPH) in order to maintain maximum production. Euclid recommends evaluating the job conditions and consult the tire manufacturer to make proper tire selection. Optional tire types, treads, ply ratings and rims available.



ELECTRICAL SYSTEM

Twenty-four volt lighting and accessories system. 175-ampere alternator with integral transistorized regulator. Eight 12-volt, heavy-duty batteries connected in series/parallel.



BODY CAPACITY

Struck (SAE)		m ³	(yd ³)
Heap 3:1	79.9	79.9	(104.5)
Heap 2:1 (SAE)	103.8	103.8	(135.8)
	115.1	115.1	(150.5)

This body is for 37.00R57(**)E4 tires use only. Body capacity and payload subject to change based on customer specific material density and application.



WEIGHTS

	kg	(lb)
Chassis with Hoist	107 330	(236 619)
Body	26 717	(58 900)
Net Machine Weight	134 047	(295 519)
Front Axle	65 683	(144 804)
Rear Axle	68 364	(150 715)

Maximum GMW with Std. Tires [37.00R57(**)E4]	324 324	(715 000)
--	---------	-----------

Including Options, 50% Fuel, Operator & Payload Not to Exceed.

Weights given are for standard options, standard body and tires. Net machine weight changes will directly effect the payload. Material density will determine body volume figures.

Payload with Standard Equipment
190 tonnes (210 tons)

Note: Nominal Payload on front cover shows 90% of Payload with Standard Equipment. Maximum GMW subject to GE approval for a given application. Net Machine Weight includes 37.00R57(**)E4 tires.

Load Weight Distribution	FRONT	REAR
	33%	67%

Options: Approximate change in Net Machine Weight:

Body Liners, Complete	kg	(lb)
	10 433	(23 000)

Note: Maximum GMW subject to Hitachi approval for a given application. Approximate Net Machine Weight with options fitted.



STEERING SYSTEM

Closed-center, full-time hydrostatic power steering system using two double-acting cylinders, pressure limit compensated piston pump, and a brake actuation/steering system reservoir. An accumulator provides supplementary steering in accordance with SAE J1511/ISO 5010. Tilt/telescopic steering wheel with 35° of tilt and 57.15 mm (2.25") telescopic travel is standard.

Steering Angle	41°
Turning Diameter (SAE)	25.6 m (84'0")
Steering Pump Output (@ 1 900 min ⁻¹ (rpm))	186.5 L/min (49.4 gpm)
System Operating Pressure	20 685 kPa (3 000 psi)



HYDRAULIC SYSTEM

Two (2) Hitachi three-stage, double-acting cylinders with cushioning in retraction, containing dual rod seals and rubber energized scrapers, inverted and outboard mounted. Separate reservoir and tandem gear pump connects with a four-position electric pilot controlled hoist valve. Electronic controller is mounted to operator's seat.

Body Raise Time	17.9 s
Hoist Pump Output (@ 1 900 min ⁻¹ (rpm))	607.0 L/min (160.0 gpm)
System Relief Pressure	18 960 kPa (2 750 psi)



BRAKE SYSTEM

Brake systems meet or surpass SAE J1473/ISO 3450.

Service

All-hydraulic actuated braking system provides precise braking control and quick system response. The system is pressure proportioned, front to rear, for improved slippery road control. Three calipers per front disc, one caliper per rear disc are utilized. The main valves are conveniently located on the firewall. This placement enhances service-ability as all pressure checks and system troubleshooting can be made at a central location. A primary accumulator stores oil under sufficient pressure to ensure 100% braking capacity is always available.

Front Axle - Dry Disc

Disc Diameter Each (2 discs/axle)	106.0 cm	(42 in)
Brake Surface Area Per Axle	15 001 cm ²	(2 325 in ²)
Lining Area per Axle	6 194 cm ²	(960 in ²)
Brake Pressure (Max.)	18 961 kPa	(2 750 psi)

Rear Axle - Armature Speed Dry Disc

Disc Diameter Each (4 discs/axle)	63.5 cm	(25 in)
Brake Surface Area Per Axle	14 298 cm ²	(2 216 in ²)
Lining Area per Axle	2 839 cm ²	(440 in ²)
Brake Pressure (Max.)	13 790 kPa	(2 000 psi)

Operation

Two independent hydraulic circuits within the service brake system provide fully modulated reserve braking capability. The system is automatically applied when loss of pressure is detected.

Parking

Spring-on, hydraulic-off park brake heads provide parking capability. The braking system complies with SAE J1473/ISO 3450.

Retarder

Retardation on grades is achieved through D.C. wheel motors in conjunction with the General Electric resistor grid package located on the cab deck. Cooling for the grid package is achieved with forced air flow provided by dual blowers driven by a single electric motor. Three-step extended range retardation package is standard.

Maximum dynamic retarding:
Standard 14 Element 3 step @ 1 390 Amps
2 760 kW (3 700HP) up to 4 877 m (16 000 ft) altitude

Optional 7 step @ 1 390 Amps
2 760 kW (3 700HP) up to 4 877 m (16 000 ft) altitude

Optional 7 step @ 1 450 Amps
2 980 kW (4 000HP) up to 3 658 m (12 000 ft) altitude

Load/Dump Brake Apply

Through activation of a switch by the operator, a solenoid is energized, sending full brake pressure to apply the rear Wet Disc brakes. For use during the load and dump cycles.



COMMAND CAB III

Integral ROPS/FOPS

Command Cab III integral ROPS (Rollover Protective Structure) is standard in accordance with SAE J1040/ISO 3471.

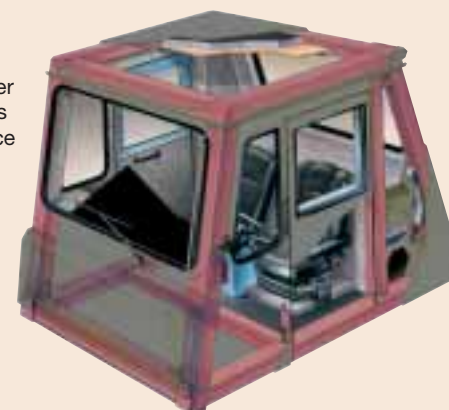

Double wall construction of 11 gauge inner and outer steel panels produces a more structurally sound cab. Foam rubber lining material along with foam rubber-backed carpeting and multiple layered floor mat act to absorb sound and control interior temperature.

A properly maintained cab from Hitachi, tested with doors and windows closed per work cycle procedures in SAE J1166, results in an operator sound exposure Leq (Equivalent Sound Level) of 81 dB(A). A three-point rubber iso-mount arrangement to the deck surface minimizes vibration to the operator compartment.

Monitoring System

CONTRONIC II monitors and diagnoses all onboard systems including Siemens drive system and engine. Data links offer complete integration, while a single multi-language Liquid Crystal Display (LCD) clearly details machine functions. Downtime is minimized with faster and more reliable troubleshooting and analysis.

HAULTRONIC II load weighing system offers benefits such as better equipment utilization on the jobsite, accurate unit and fleet production results, and benchmark unit statistics against fleet results. Cycle time, distance, cycle count can all be measured and recorded to further and improve job productivity. HAULTRONIC II is fully integrated with CONTRONIC II vehicle monitoring system and display interface, avoiding potential failure or error common in aftermarket systems.

Excellent Serviceability

A removable front closure allows easy access to the service brake valve and heater connections. The upper dash utilizes four (4) removable panels that house gauges and customer options, each individually accessible. A removable closure located behind the seat provides easy access to the shifting control, CONTRONIC II, and all electrical junction points.

Comfort and Ease of Operation

A wrap-around style dashboard positions controls within easy reach and visual contact. A full complement of easy-to-read gauges, CONTRONIC II monitoring and warning system, a spacious environment, six-way adjustable air seat, tilt/telescopic steering wheel, filtered ventilation, door locks, and a full size trainer seat, all contribute to operator safety and comfort.



SUSPENSION

Front Suspension

Independent trailing arm for each front wheel. NEOCON struts containing energy-absorbing gas and compressible NEOCON-E™ fluid are mounted between the trailing arms and frame. Variable damping and rebound feature included.

Rear Suspension

"A" frame structure, integral with axle housing, links drive axle to frame at forward center point with pin and spherical bushing. A track rod provides lateral stability between the frame and drive axle. Heavy-duty rear-mounted NEOCON struts containing energy-absorbing gas and compressible NEOCON-E fluid suspend the drive axle from the frame. Integral rebound feature included.

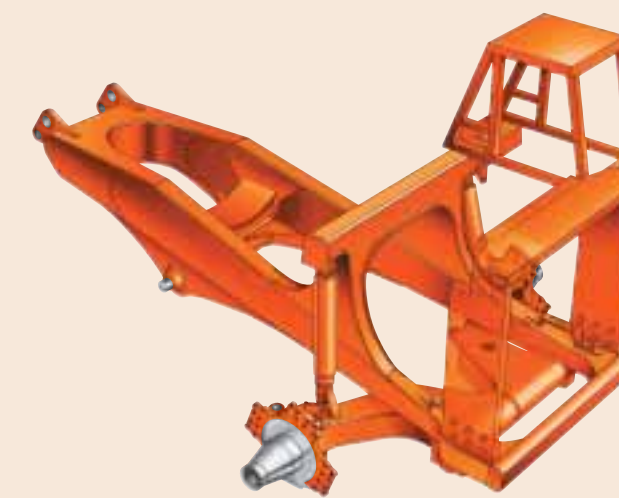

Maximum wheel oscillation 8°

The Hitachi frame and suspension are designed to work in unison to provide maximum structural integrity and operator comfort. The fabricated rectangular frame rail construction provides superior resistance to bending and torsional loads while eliminating unnecessary weight. The unique trailing arm front suspension absorbs haul road input, minimizing suspension-induced frame twisting while providing independent tire action. NEOCON ride struts are mounted with spherical bushings, eliminating extreme sidewall forces by insuring a purely axial input to the ride strut. The wide track stance of the suspension system and the long wheel base assure a more stable, comfortable ride.

The unique Hitachi NEOCON struts both front and rear combine the energy absorption characteristics of two different compressible media: NEOCON-E liquid and helium gas. They provide nearly twice the energy absorption as Nitrogen over Oil struts. The result is more comfort for the operator, maximum protection for the hauler frame, and excellent stability and control. NEOCON-E has also been approved by the US EPA and does not violate codes defined by TSCA Section 5.

The NEOCON strut outperforms competitive strut designs by improving isolation, stability, and control. Improved isolation means reduced impact loading on structural members of the machine and greater operator comfort, resulting in longer equipment life and productivity. Improved stability means more consistent dynamic response of the machine to fluctuating load energy, resulting in predictable machine performance. Improved control also means better machine maneuverability.



FRAME

The box section main frame rails are bridged by three crossmembers, front bumper and front suspension tube. The rails are constant taper, constructed of 690 N/mm² (100 000 psi) yield strength steel. Two rear crossmembers have integral suspension and drive axle mountings. Crossmember to frame rail junctions employ large radii transitions to minimize stress concentrations.



BODY

The body has a flat floor, sloped tailchute, and is continuously exhaust-heated. Extended canopy protects service deck area. High yield strength, 690 N/mm² (100 000 psi) alloy steel is used in the following thicknesses:

	mm	(in)
Floor	19	(0.75)
Front	10	(0.39)
Sides	10	(0.39)
Canopy	6	(0.24)

High strength 690 N/mm² (100 000 psi) alloy steel is also used for the canopy side members and floor stiffeners. The body is rubber cushioned on the frame.

The Hitachi horizontal stiffener design minimizes stress concentrations, by dissipating load shocks over the entire body length. Closely spaced stiffeners provide additional protection by minimizing distances between unsupported areas.

Note: This body is for 37.00R57(**)E4 tires use only.



SERVICE CAPACITIES

	L	(US gal)
Crankcase (incl. filters)		
Detroit Diesel 12V-4000	213.0	(56.3)
Cooling System	322.7	(85.3)
Fuel Tank	2 838.8	(750.0)
Hydraulics		
Hoist System	565.9	(149.5)
Steering System	189.3	(50.0)
GE 788 wheel motor (per wheel)	39.7	(10.5)
Windshield washer	3.8	(1.0)