

EG70R



Full 360° Rotating Type Rubber Crawler Carrier

- Model Code : EG70R-3
- Engine Rated Output : 140 kW (190 PS)
- Machine Weight : 11 500 kg
- Maximum Payload : 6 500 kg

Cutting-Edge Technologies for Environmental Protection and Operator Comfort

The Hitachi EG70R is packed with technological edges for operator comfort and environmental protection. The robust cab, proven on the ZAXIS-3 series, increases safety and operator comfort. The clean engine, complying with the new emission regulations in the world, allows environmentally friendly operation, without sacrificing mobility and productivity of the machine.



Environmental Technologies

The clean engine, complying with the Emission Regulations Tier 3 and Stage IIIA in the EU, USA and Japan, makes remarkable emission reduction, including NOx (nitrogen oxide) and PM (particulate matter).

The low noise engine and hermetically sealed cover further reduce noise (down 3 dB(A) from the conventional).

Recyclable aluminum radiator.

Operator Comfort and Safety

ROPS* Cab

2.5-fold withstanding force



The ROPS cab has the robust structure to increase operator safety in the case of tipping accident. For example, the cab top, when subjected to horizontal force, can withstand 2.5 times the conventional.

*Roll-Over Protective Structure to protect the operator held by seat belt

Right-Side Downward Visibility



Visibility is improved with enlarged glass windows and transversely arranged engine, especially right-side downward visibility during traveling.

Inclinometer



The operator can read the inclination of the machine with an inclinometer.

Multi-Function Monitor



With the large multi-function LCD monitor, the operator can read various operating information at a glance. The monitor is positioned ergonomically for easy reading.

Comfortable Cab



The Hitachi ZAXIS-3 type cab is utilized for operator comfort. The seat back is wide enough to hold the operator. The silicone-filled rubber cushions enhance pleasant operation with less operator fatigue.

Productivity

More Production with Less Fuel Consumption

Engine Output: 5% Increase

(vs. Conventional)

Fuel Consumption: 20% Reduction

(vs. Conventional in Travel Test)

Full 360° Rotation with Good Visibility



A full 360° rotation and increased visibility allow efficient positioning for productive loading and side dumping on road shoulders.

Enhanced Stability

The low dump body helps increase operating efficiency and stability.

Durability

Rugged Dump Body



The D-section frame edges, already proven on the Hitachi hydraulic excavators, strengthen the sides of the dump body. The bottom plates are made of high-tensile steel.

Tough Undercarriage

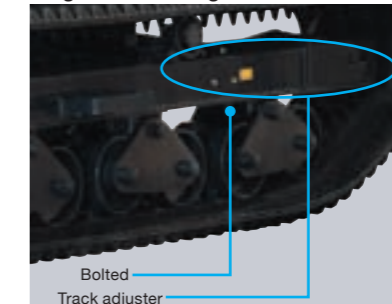

The lower rollers are induction-hardened. The body assembly is bolted for lower running costs. The track adjuster is job-proven on the Hitachi hydraulic excavators.

Maintainability

Easy-to-Clean Radiator



The radiator, oil cooler and intercooler are arranged in parallel, instead of the conventional in-line arrangement, for simple, efficient cleaning.

Simplified Oil Draining



The engine oil pan is provided with a drain coupler for quick draining, using an associated hose.

DIMENSIONS

Unit: mm

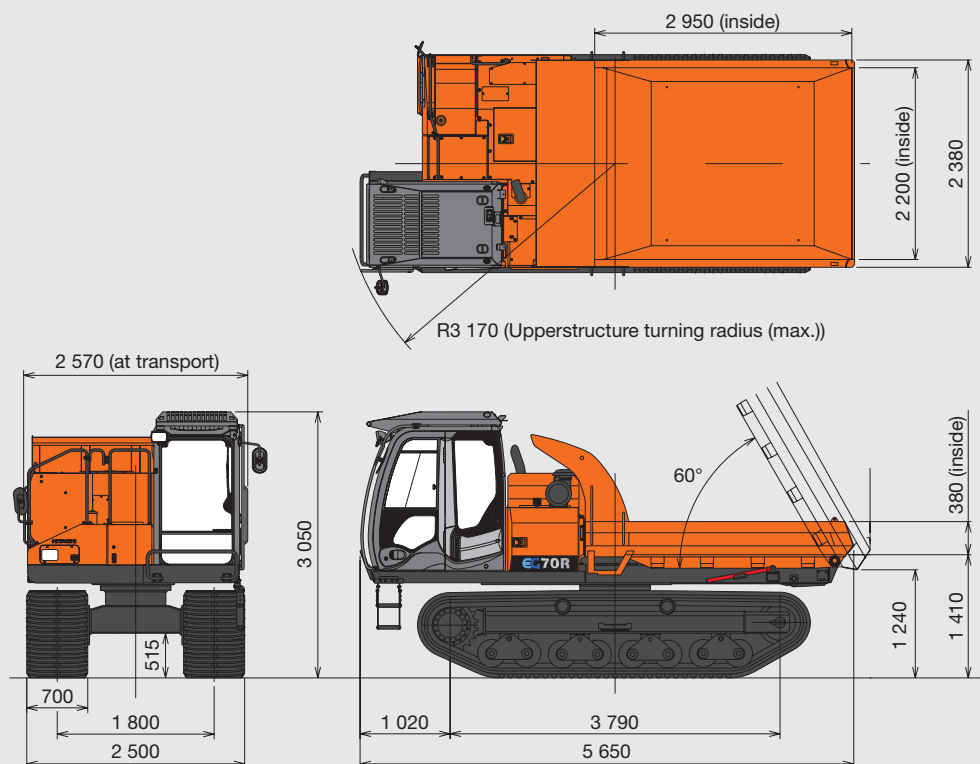

SPECIFICATIONS

		EG70R
		Scoop-end body
Operating weight		11 500 kg
Maximum payload		6 500 kg
Dump body capacity struck/heaped		2.20 m ³ / 3.76 m ³
Engine	Make and model	Isuzu AH-4HK1X
	Type	Water-cooled, 4-cycle, direct injection
	Rated power	140 kW / 2 100 min ⁻¹ (190 PS / 2 100 rpm)
	Displacement	5.193 L (5 193 cc)
Ground pressure	Unloaded	21 kPa (0.22 kgf/cm ²)
	Loaded	33 kPa (0.34 kgf/cm ²)
Drive system		Fully hydraulic (2-pump 2-motor *HST)
Shoe type		Steel-cored rubber shoes
Shoe width		700 mm
Swing speed		4 min ⁻¹ (4 rpm)
Travel speeds	Low	0 - 6.0 km/h
	High	0 - 8.5 km/h
Fuel tank capacity		165 L

Data is expressed in SI units, followed by reference data in conventional units. *HST : Hydro Static Transmission

OPTIONS

- Rear gate body
- Strengthened bottom plate

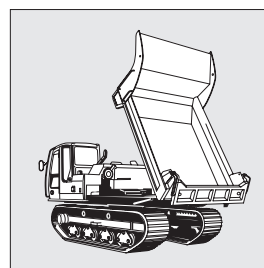

Rear gate body

These specifications are subject to change without notice.

Illustrations and photos show the standard models, and may or may not include optional equipment, accessories, and all standard equipment with some differences in color and features.

Before use, read and understand the Operator's Manual for proper operation.