

740

EJECTOR
Articulated Truck



Cat® Engine 3406E ATAAC EUI

Gross Power 329 kW/441 hp

Flywheel Power 309 kW/415 hp

Weights

Rated Payload 38 metric tons

Body Capacities

Heaped SAE 2:1 23.1 m³

740 Ejector Articulated Truck

The 740 Caterpillar® Ejector Articulated Truck is Simply the Best.

Performance and Productivity – Powertrain

- ✓ The 3406E air-to-air aftercooled (ATAAC) engine delivers higher power and a more aggressive torque rise. This electronic engine provides outstanding performance and complete system integration with the transmission. **pg. 4**

Operator Comfort

- ✓ Larger center-mounted cab, oscillating front axle, air-suspension seat, full-size trainer seat and increased storage space provide exceptional operator comfort. **pg. 6**

Ease of Operation

- ✓ Ergonomically designed wrap-around dash, tilt and telescoping steering wheel, easy-to-reach controls and better all-around viewing promote fast, confident machine operation. **pg. 7**

Performance and Productivity – Suspension and Traction Control

- ✓ Cross-axle differential locking system provides full driveline locking for maximum performance in adverse conditions. Three-point front suspension provides a smoother ride, allowing the operator to travel faster over rough terrain. **pg. 5**

Better than all the rest, the 740 Ejector truck offers proven reliability and durability, high performance, low fuel consumption, operator comfort and low operating costs.



✓ *New Feature*

**Performance and Productivity –
Ejector Truck**

- ✓ The truck body features on-the-go ejecting capability and a self-cleaning ejector design, which offers cleaner load ejection and overcomes carry-back of sticky materials. **pg. 8**

Durability and Reliability

- ✓ The 740 Ejector truck has built-in durability and reliability. Cat purpose-built articulated truck drivetrain components, redesigned front frame and hitch ensure maximum performance in the toughest applications. **pg. 9**

Serviceability

Longer service intervals and easier maintenance result in better machine availability, as well as lower owning and operating costs. **pg. 10**

Complete Customer Support

Your Cat dealer offers a wide range of services that can be set up under a customer support agreement when you purchase your equipment. The dealer will help you choose a plan that can cover everything from machine configuration to eventual replacement. **pg. 11**



Performance and Productivity – Powertrain

Integrated powertrain with more power, greater performance and lower fuel consumption – the power to do more work.



3406E Electronic Engine. The electronic version of this proven engine delivers higher power, durability and complete system integration of the engine and transmission for maximum efficiency.

High Torque Rise. Provides unequaled lugging force during acceleration, on steep grades and in tough underfoot conditions.

Turbocharged and ATAAC. Air-to-air aftercooling provides improved fuel economy by packing cooler, denser air into cylinders for more complete combustion of fuel and lower emissions.

Electronic Control Module (ECM). Advanced Diesel Engine Management III (ADEM III) provides improved emissions, performance, advanced troubleshooting and diagnostic capabilities.

Fuel Efficiency. The electronically controlled, computer actuated unit injection fuel system has high injection pressure for complete fuel combustion, greater fuel efficiency and reduced emissions.

Controlled Throttle Shifting.

CTS significantly reduces powertrain stress and clutch wear by controlling engine speed, torque converter lock up and transmission clutch engagements.

Engine Construction. Since 1974, the 3406 engine has been the benchmark for heavy-duty reliability and performance. The latest electronic version incorporates major updates to keep it ahead of the rest. Cylinder head with overhead camshaft and a pendulum shock absorber improve efficiency and increase reliability.

Electronic Transmission. The seven-speed electronic transmission is based on the proven design of the Cat 769 Off-Highway Truck. It features Individual Clutch Modulation (ICM) to ensure constant shift times even when the oil is cold.

Engine Compression Brake.

The standard Jake Brake® provides extra braking effort on downhill grades. It is an excellent match for the 3406E engine, turning it into a power-absorbing air compressor. It has very fast response time and produces no additional heat, so it can be used continuously. Four modes of operation provide an optimum match between operating conditions and retarding power.



Performance and Productivity

Suspension systems and traction control – delivering power to the ground in all conditions.

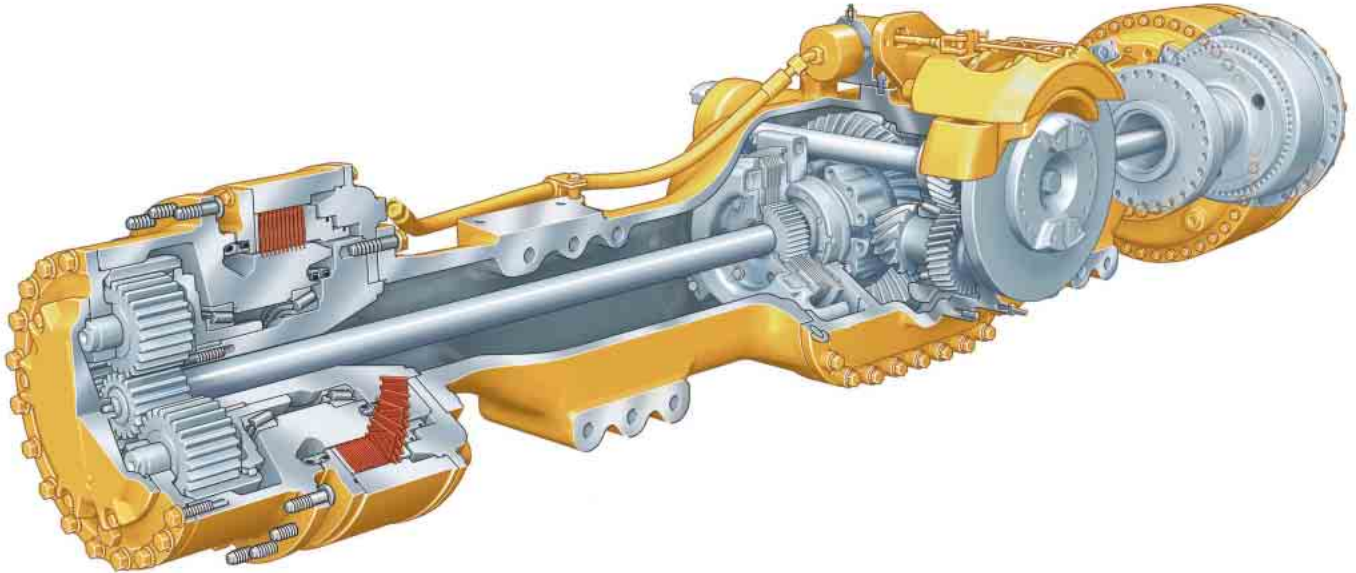

Front Suspension. The three-point front suspension permits the axle to oscillate $\pm 6^\circ$, softening impact loads on structures and components and providing a smoother ride, so the operator can travel faster over rough terrain.

Rear Suspension. Features a walking beam geometry that provides a stable ride for excellent load retention.

Traction Control. The traction control system is comprised of a wet clutched inter-axle differential and wet clutched cross-axle differentials. All differentials can be engaged and disengaged on-the-go for maximum versatility. When used together, the differentials provide 100 percent driveline locking.

Inter-Axle Differential Lock. Locks all three axles in unison and modifies torque distribution for excellent traction in poor underfoot conditions and on grades. It is operated by a switch located at the footrest.

Cross-Axle Differential Locks. Provides full driveline locking – all three axles and all six wheels – for maximum performance in the most adverse conditions. Acts in unison with the inter-axle differential lock when the footswitch is actuated and the dash-mounted switch is selected.

Enclosed, Oil-Cooled Brakes. Multi-plate oil-immersed brakes are fitted to both front and center axles. These brakes provide outstanding stopping capability, while maintaining maximum durability and life.

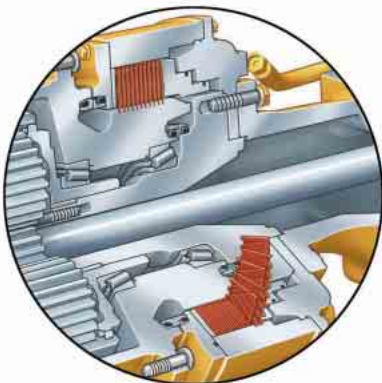

Service brake detail

Operator Comfort

The operator's office – high productivity from a comfortable, motivated operator.



Ride Comfort. The new front suspension with its oscillating axle and low pressure ride struts, combined with the new center-mounted cab, offers unrivaled levels of ride comfort for the operator in all driving conditions. Operators remain comfortable and productive throughout the day.

Spacious Two-Person Cab.

The 740 features a large two-person cab – 41 percent larger than the E Series II – offering comfortable working space for both the operator and trainer or trainee. All 700 Family articulated trucks use the same spacious cab design.

Air Suspension Seat. The air suspension seat enhances operator comfort with a dual-sided support recliner and thicker cushions. It is fully adjustable to provide an optimal driving position.

Trainer Seat. Full-size trainer seat features a fully padded seat with a backrest and a wide seatbelt for a secure and comfortable ride. The trainer seat is positioned next to the operator seat, giving both the operator and trainer clear view of the instrument panel, controls and the road.

Storage Space. More storage space to create a safe, secure and uncluttered working environment.

Heating/Ventilation/Air Conditioning. Twelve vents provide air distribution to keep the operator comfortable and to provide rapid defrosting of all windows. Heating, air conditioning and defrosting are standard. The recirculation filter is positioned for easy servicing.

Sound Levels. Cab mounts are designed to reduce noise and vibration in the cab. All connections to the cab are resiliently mounted. The operator's station makes extensive use of sound-absorbing and barrier materials to keep sound levels low.

Steering Column. Offers telescoping and tilting features to provide a comfortable driving position.



Ease of Operation

Designed for simple, easy operation, the 740 Ejector Truck allows the operator to focus on production.

Ergonomic Layout. The controls and layout of the cab are designed to make it as easy to operate as your car. Quick, easy to read and simple to operate, the controls and gauges on the 740 allow the operator to concentrate on production.

Dash. The wrap-around dash puts all controls within easy reach of the operator. It provides an automotive feel with the industrial strength you would expect from Caterpillar.

Viewing Area. The low sloping hood, made possible by placing much of the cooling package behind the cab, gives the operator excellent all-around visibility. The larger glass area and central operator position further enhance visibility, resulting in more operator confidence and faster cycle times.

Differential Lock Controls. The switch for the inter-axle differential lock has been positioned in the operator's footrest for ease of operation. An additional dash-mounted switch is all that is required to select full driveline lock-up. Disengaging the foot switch disengages all differential locks immediately.



Transmission and Ejector Levers.

Finger tip controls allow easy operation and low effort. The ejector lever has been redesigned and repositioned to provide easy and comfortable operation. The transmission lever continues to offer excellent comfort along with controls for top gear limit, transmission hold and neutral lock.

Suspended Pedals. New suspended pedals are easier to operate and reach, while creating more leg and foot room. They also make for easier cleaning of the cab floor by keeping the pedals out of the dirt.

Electronic Monitoring System (EMS III).

Constantly monitors critical machine functions, alerts operators to potentially damaging problems before failures occur, and indicates when certain functions are in use. EMS III offers added memory and improved performance. It is also flashable, allowing the software to be easily updated. The system continues to use three levels of alert.



Performance and Productivity – Ejector

Designed to disperse the load on-the-go for faster cycle times and lower spreading costs.



Ejector. The 740 Ejector is designed to disperse the load on-the-go for faster cycle times and lower spreading costs. The ejector body also offers clean load ejection and the capability to work in areas with restricted overhead clearance and soft underfoot conditions.

Versatility. The 740 Ejector is based on the standard 740 Articulated Truck and shares all its versatility. It can operate in the same conditions, yet offers a number of unique capabilities that stretch the operation envelope.

Spreading. The truck can eject the material and spread it out while moving, reducing the size of additional spreading and dozing equipment. This makes the 740 Ejector an ideal solution for road building and landfill applications. On-the-go ejecting results in faster cycle times and reduced power train loads.

Stability. Ejecting the load without raising the body increases stability, allowing load dispersal on inclines, side slopes and in very soft underfoot conditions that would be unacceptable with a conventional truck, but ideal for the ejector, especially on landfill sites.

Overhead Clearance. Because the body is not raised when ejecting the load, the truck can be utilized in areas with reduced overhead clearance such as when working around overhead lines, conveyors and bridges. The ejector is also ideal for tunneling and underground operations.

Carry-Back. The design of the ejector is inherently self-cleaning and practically eliminates material sticking to the body, which increases productivity, improves fuel efficiency and lowers cost per ton.

Body. The reinforced body is made from thick high-yield, heat-treated steel that provides exceptional strength and durability. The ejector top rails are made from high-strength alloy steel identical to the Cat 769D Off-Highway Truck. For optimum durability and wear life, the ejector body is designed to work in applications where the material consists of rocks smaller than 152 mm in diameter.

Durability and Reliability

High availability leads to high productivity. Excellent durability keeps ownership costs low.

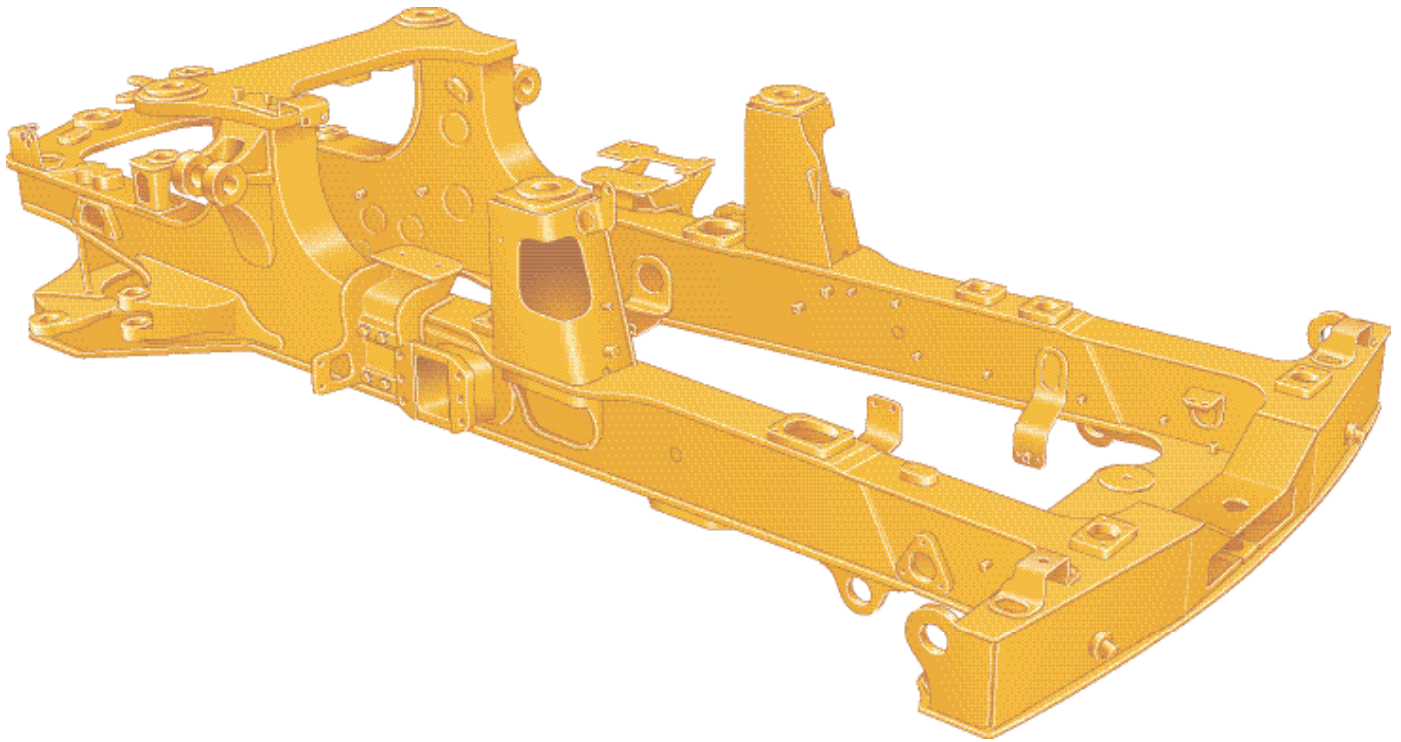

Front Frame. New front frame design features a large box section and wide, stiff frame beams to handle torque loads. The divergent frame design decreases stress in the hitch area and optimizes suspension geometry. The design incorporates advanced technologies such as Finite Element Analysis to optimize the frame before the first machines are ever built. The frame design makes maximum use of robotic welding for increased durability.

Rear Frame. Twin-box construction developed for the E-Series II trucks and proven in countless applications throughout the world. The design minimizes stress concentrations and provides low weight with long service life.

Castings. Both front and rear frames make extensive use of heavy-duty steel castings to handle stress concentrations.

Suspension. New front suspension provides unparalleled ride quality. It also protects the truck from the most adverse road conditions by absorbing shock loads that would otherwise reach the frame.

Articulated/Oscillating Hitch.

The articulating hitch provides the truck with steering articulation, and the oscillation ensures all-wheel ground contact in rough terrain.

Hitch Construction. New two-piece bolted hitch features a strong and durable cast steel head bolted to a hard-wearing forged steel tube. The hitch tube has hardened bearing areas and a hardened thrust face for reduced maintenance and longer life.



Serviceability

More time on production, less time and money spent on servicing.

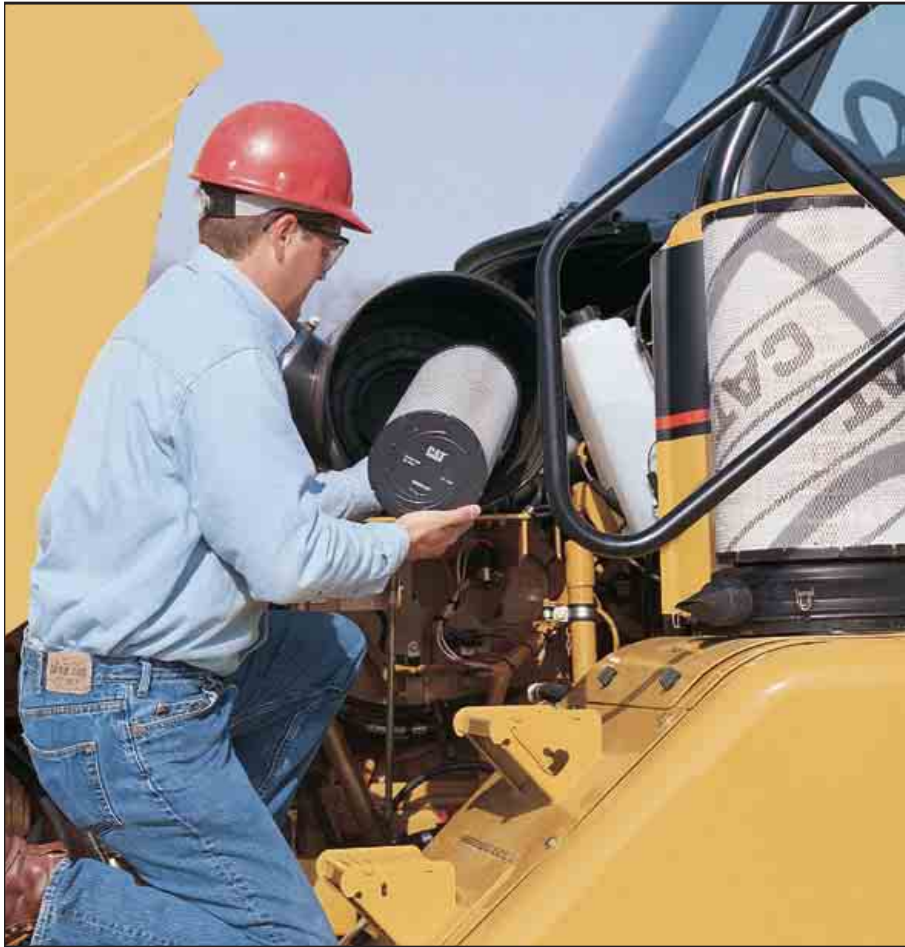

Extended Service Intervals. Increased engine oil change and hydraulic oil change intervals.

Test and Lube Points. Test points are grouped together behind the cab and are accessible from the ground. Lube points are grouped at the rear of the front frame and the front of the rear frame.

Service Points. Engine and transmission dipstick and fill caps, air and fuel filters and the fuel-priming pump are all mounted on the left side of the engine under the hood. Coolant level indicator and fill cap are outside the cab.

Radiator. The radiator package is located behind the cab, which provides improved access to both inlet and outlet sides of the radiator. The ATAAC radiator is located at the front of the truck.

Extended Life Coolant. Extends the change interval and improves component life by reducing aluminum corrosion.

Hood. The hood is raised and lowered electrically, minimizing operator effort when servicing the machine. A manual override is also provided.

Electrical Service Center. Located inside the cab, this service center provides a power port, diagnostic connector and Cat Data Link connector.

Cat Data Link Connector. The Cat Data Link connector provides a plug-in using a laptop computer with Electronic Technician (ET) software. The Cat Data Link port performs programming functions on all electronic controls.

Service Access. The cab tilts to the side to provide easier access underneath, which simplifies servicing of the transmission, drive shafts and hydraulic pumps. Accessibility to machine electrical and hydraulic interfaces has also been improved. They are located on the right side of the cab, behind a removable cab body panel.

Truck Transport. The new suspension system eliminates the need to lower the suspension when transporting the truck, reducing maintenance and downtime.

Output Transfer Gear. The OTG provides lubrication of all bearings and clutches using a distributed-pressure lubricated and filtered system, which replaces the previous splash-lubricated system on the E Series II. Better lubrication and filtration reduce service and repair. In addition, improved lip seals on output yokes decrease the chance of leaks.

Complete Customer Support

Cat dealer services help you operate longer with lower costs.

Selection. Make detailed comparisons of the machines you are considering before you buy. What are the job requirements, machine attachments and operating hours? What is your need for machine availability and do you have the proper loading tool match? Your Cat dealer can help.

Custom Products. The 740 is compatible with a wide range of Caterpillar and auxiliary equipment manufacturers' specialized products. This multi-purpose hauling system was designed for use with a common tractor and a variety of trailer options to suit different market segments such as waste, forestry, tunneling, earthmoving and agriculture.

Purchase. Look past the initial price, look at the value the 740 offers. Consider the resale value, compare productivity and day-to-day operating costs and fuel consumption. Consult your local Cat dealer for financing options.

Operation. For the best operating techniques to increase productivity and your profit, turn to your Cat dealer for the latest training literature and trained staff.



Maintenance. Repair option programs guarantee the cost of repairs up front. Diagnostic programs such as S•O•Ssm and Technical Analysis help you avoid unscheduled repairs.

Replacement. Repair or rebuild? Caterpillar trucks are designed for longer life with rebuildable components. Your Cat dealer can help you evaluate the cost involved so you can make the right choice.

Product Support. The 740 offers easy maintenance with combined service points and extended service intervals to keep the machine running longer. Your local Cat dealership will be with you every step of the way with its unsurpassed worldwide parts support, trained technicians and customer support agreements.

Warranty. Your local Cat dealer is there to support and protect you. Extended warranty options are also available.

Engine

Cat 3406E ATAAC EUI

Rating	1900 rpm
Gross Power	329 kW/441 hp
Flywheel Power	
ISO 9249	309 kW/415 hp
EEC 80/1269	309 kW/415 hp
Bore	137 mm
Stroke	165 mm
Displacement	14.6 liters

- The 740 Ejector truck meets Stage II emission specifications for Europe through 2005.
- No engine derating required below 2438 m.

Weights

Rated Payload	38 metric tons
---------------	----------------

Transmission

Forward	km/h
1	9.3
2	12.8
3	17.0
4	22.5
5	30.5
6	40.6
7	55.1
Reverse	13.4

Body Capacities

Heaped SAE 2:1	23.1 m ³
Struck	17.8 m ³
Heaped SAE 1:1	28.5 m ³

Ejector Cycle Times

Eject Time	14 seconds
Retract Time	24 seconds

- With true on-the-go capability, the eject and retract times become less important as the machine does not have to stop to eject the load and the blade retracts during the return leg of the cycle.

Operating Weights

Empty	kg
Front axle	19 910
Center axle	8030
Rear axle	7330
Total	35 270

Rated Load	
Front axle	1640
Center axle	18 180
Rear axle	18 180
Total	38 000

Loaded	
Front axle	21 550
Center axle	26 210
Rear axle	25 510
Total	73 270

Body Plate Thickness

Front	6 mm
Side	6 mm
Base	10 mm

Service Refill Capacities

	Liters
Fuel Tank	560
Cooling System	80
Hydraulic System	233
Engine Crankcase	38
Transmission	72
Final Drives/Differential	80
Output Transfer Gear	21

Sound Levels

Interior Cab	79 dB(A)
--------------	----------

Standards

Brakes	ISO 3450-1998
Cab/FOPS	ISO 3449-1992 Level II
Cab/ROPS	ISO 3471-1994

Optimal Loader/Truck Pass Matching

Hydraulic Excavators	385B L ME	365B II L ME	345B II L ME	
Loader Capacity (metric tons) – 50 min/h	954-1193	750-1100	665-805	
Passes	4	5	6-7	
Wheel Loaders	988G	980G II	972G II	966G II
Loader Capacity (metric tons) – 50 min/h	565-790	590-650	490-565	400-535
Passes	3-4	4	5	6

An optimum system match gives you a major productivity advantage. The 740 is an excellent match for the Cat 365B II L and 385B L Hydraulic Excavators; and 972G II, 980G II and 988G Wheel Loaders. Thus results in increased production and lower system costs per unit of volume moved.

Gradeability/Speed/Rimpull

To determine performance, read from Gross Weight down to % Total Resistance. Total Resistance equals actual % grade plus 1% for each 10 kg/metric ton of Rolling Resistance. From this point, read horizontally to the curve with the highest attainable speed range. Then, go down to Maximum Speed. Usable Rimpull depends on traction available.

- E – Empty 35 270 kg
- L – Loaded 73 270 kg
- 1 – 1st Gear
- 2 – 2nd Gear
- 3 – 3rd Gear
- 4 – 4th Gear
- 5 – 5th Gear
- 6 – 6th Gear
- 7 – 7th Gear

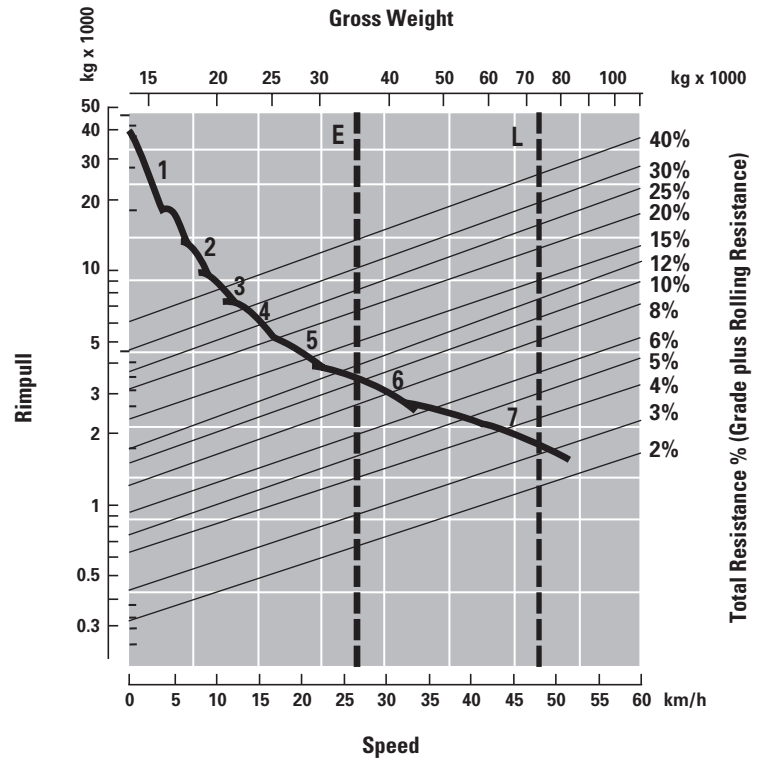

Retarding Performance

To determine performance, read from Gross Weight down to % Effective Grade. Effective Grade equals actual % favorable grade plus 1% for each 10 kg/metric ton of Rolling Resistance. From this point, read horizontally to the curve with the highest attainable speed range. Then, go down to Maximum Speed. Retarding effect on these curves represents full application of the retarder.

- E – Empty 35 270 kg
- L – Loaded 73 270 kg
- 1 – 1st Gear
- 2 – 2nd Gear
- 3 – 3rd Gear
- 4 – 4th Gear
- 5 – 5th Gear
- 6 – 6th Gear
- 7 – 7th Gear

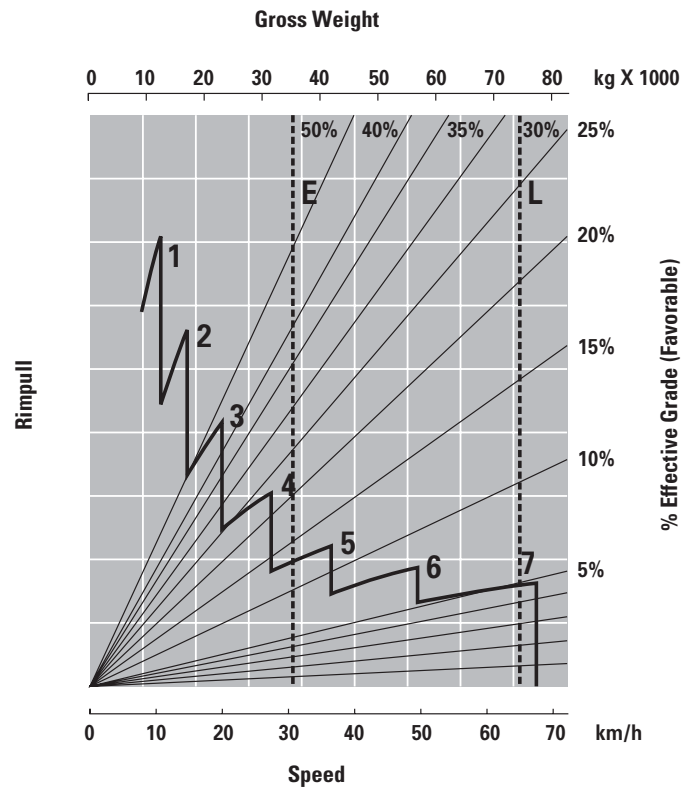

Dimensions

All dimensions are approximate.

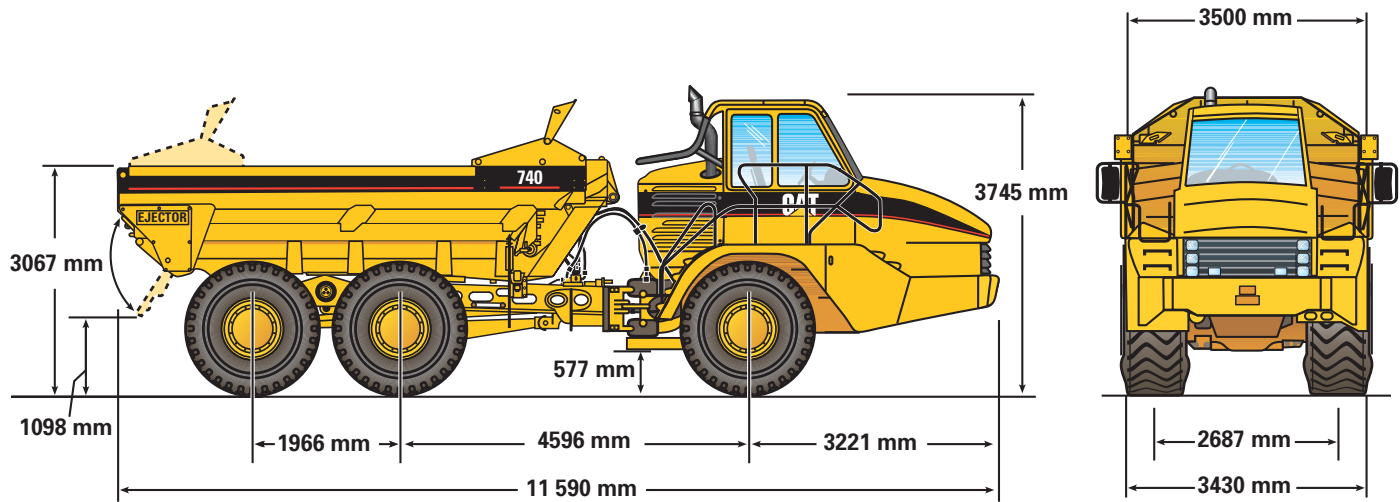

Turning Circle

Dimensions are for machines equipped with 29.5R25 tires.

Turning dimensions

Steer angle – left/right	45°
SAE turning radius	8 633 mm
Clearance radius	9 090 mm
Inside radius	4 470 mm
Aisle width	5 930 mm

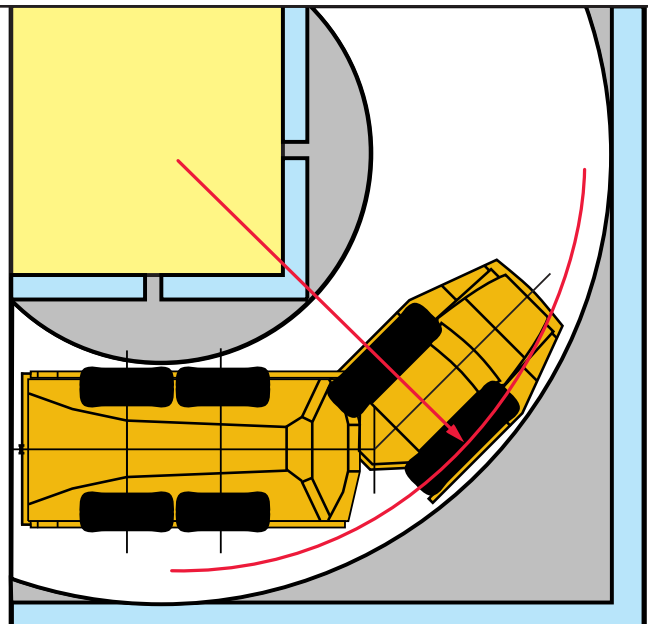

Standard Equipment

Standard equipment may vary. Consult your Caterpillar dealer for specifics.

Air conditioning with R134A refrigerant	Mirrors, left and right	Secondary steering
Air vents, adjustable	Mud flaps, body mounted	S•O•S sm sampling valves
Back up alarm	Radio ready	Spillguard: front, integral part of fabricated body
Body, including Ejector cylinder and blade with integrated spillguard	ROPS/FOPS cab with full instrumentation including:	Standard differentials, clutched cross-axle for all axles
Electrical system: 24 volt, 2.5A 24 to 12 volt converter	– Electronic Monitoring System panel: alternator, coolant temperature, brake oil pressure, engine oil pressure, low fuel indicator	Starting receptacle, electric, remote
Engine compression brake	– Gauges: fuel (in cab), torque converter temperature.	Storage – two cup holders, under seat storage, door pocket, behind seat storage, coat hook.
Ether start ready	– Indicator lights: direction, hazard, headlights, high beam only, cross axle differential lock-up, parking brake, transmission/torque converter lock-up	Sun visor
Glass windows, toughened and tinted, front and rear	– Meters: service hour meter, speedometer, tachometer	Tailgate, hydraulic automatic
Guards: rear window and radiator, crankcase and axle	Seat, fully adjustable seat with air suspension	Tires, 29.5R25, radial, Michelin XADN
Headlights, four with dimmer switch	Seat, padded companion/trainer	Tow pins front and rear
Heater and defroster with three-speed fan	Seatbelts, two retractable	Vandalism protection: lockable caps for fuel tank, hydraulic oil tank and radiator
Horn, electric		Windows opening side, tinted
Lights: cab interior, front, side, rear, two reversing/working lights, two stop/tail lights		Windshield wiper and washer, intermittent (front and rear)

Optional Equipment

Optional equipment may vary. Consult your Caterpillar dealer for specifics.

Body liners	Sound suppression spectator
Ether start canister	Tires, 29.5 R25 Goodyear RL2+
Heated rearview mirrors	Tool kit

740 Ejector Articulated Truck

HEHM5467-1 (08/2003) hr

Materials and specifications are subject to change without notice.
Featured machines in photos may include additional equipment.
See your Caterpillar dealer for available options.

www.CAT.com

© 2003 Caterpillar

CATERPILLAR[®]