

Cat[®] Articulated Truck Bare Chassis Application Guide



Table of Contents

Definitions	3
Available Configurations	4
Long Rear-frame Solutions	5
Machine Weights	6-7
Machine Dimensions	8-9
Center of Gravity	10-11
Hydraulic Specifications	12
General Welding Tips	13
Tire Options / Body Parts	14
ROPS / Turning Radius	15
Reference Material	16

Count on Caterpillar to provide a proven, high-performance and durable platform . . . while letting OEMs focus on their custom attachment expertise.

Ranging from standard to long wheel base rear frames, Cat® Articulated Truck (AT) Bare Chassis support a number of applications, such as large-volume coal or trash dump bodies, water tanks, fuel and lube trucks, and other unique machines requiring high mobility. Caterpillar works with Cat Dealers and OEMs to determine the best possible solutions for mounting a variety of implements and bodies onto the Cat AT bare chassis, providing the knowledge and support to assist with application and integration. These machines are available with and without hoist cylinders.

Customer support is our focus. You can count on the Cat global distribution and support system wherever you, your machines or your customers are located. Cat Dealer service parts availability provides the quick turnaround customers expect.

Caterpillar OEM Solutions Group can work with OEMs and Cat Dealers to provide application support for customers working with AT bare chassis. This work is included with new truck sales. On projects where a used chassis is involved, there may be a charge for engineering work done. OEM Solutions Group regional sales managers will assist dealers/customers in locating OEMs who can provide a variety of attachments and specialty bodies, thus providing customers with a full solution. Please contact your local OEM Solutions Group office for more information.

Definitions

AT: Articulated Truck

AT Bare Chassis: Articulated Truck sold without a dump body

OEM: Original Equipment Manufacturer

AEM: Aftermarket Equipment Manufacturer

CMOPS: Corporate Machine Order Processing System

Available Configurations

ATs can be ordered with or without hoist cylinders and in standard wheel base (SWB) or long wheel base (LWB). These configurations are available through Caterpillar OEM Solutions Group, and are also available to Cat Dealers through the standard AT price lists and can be ordered through CMOPS.

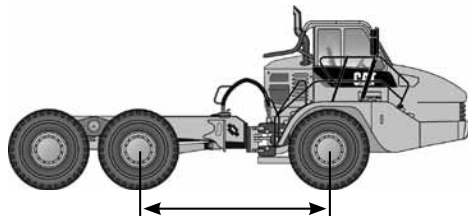

Standard Wheel Base

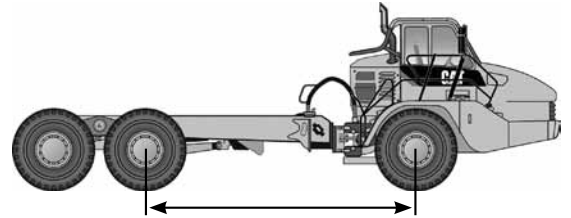

Long Wheel Base

Base Model	Standard Wheel Base		Long Wheel Base	
	Payload tonnes/tons	Wheel Base Length mm/in	Payload tonnes/tons	Wheel Base Length mm/in
725	27.3 / 30.1	3819 / 150.4	26.8 / 29.5	5305 / 208.9
730	32 / 35.1	3819 / 150.4	31.2 / 34.4	5305 / 208.9
735	36.9 / 40.7	4244 / 167.1	35.8 / 39.5	5800 / 228.3
740	42.9 / 47.3	4244 / 167.1	41.8 / 46.1	5800 / 228.3

Long Rear-frame Solutions for Cat AT Bare Chassis

To address the challenges of payloads other than heaped dirt—including applications such as water trucks, coal or trash dump bodies—where the payload center of gravity tends to be pushed rearward, Caterpillar offers a longer rear frame as an option. These are called AT long wheel base (LWB) bare chassis machines, and they offer rear frames that are approximately 60 inches (1500 mm) longer than standard. This gives customers the best platform to install alternative attachments. OEM Solutions works with Cat Dealers, owners, users and OEMs to determine the best solutions for mounting a variety of implements and bodies onto the AT bare chassis. For more information, [click here](#) or contact your Cat Dealer or OEM Solutions account manager.

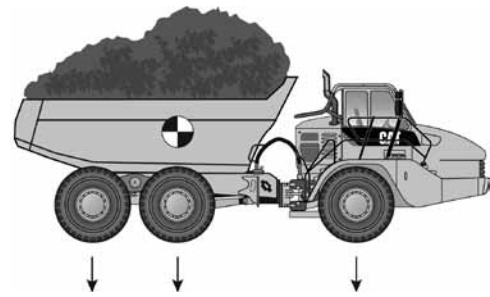

Figure 1. Body, wheelbase and standard rear frame are designed for high-volume dirt-hauling applications.

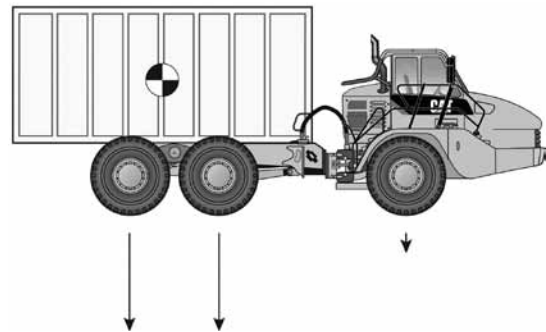

Figure 2. Installing a custom body that is longer than the typical dump body pushes the payload center of gravity rearward, adversely affecting steering, braking, mobility, ride and frame loading.

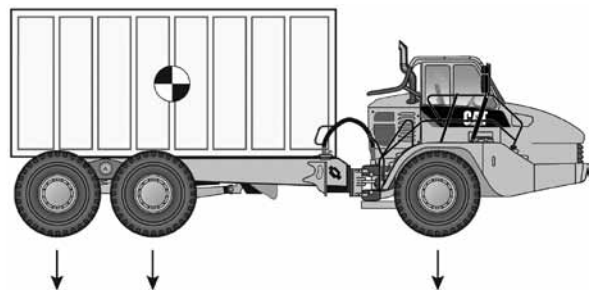

Figure 3. Using a longer wheelbase rear frame addresses the payload center of gravity being shifted rearward and allows loading all axles to achieve maximum machine payload capability.

Machine Operating Weights

The empty, maximum payloads and gross machine weights are listed below. Care must be taken when designing any attachment so that axle weight limits are not exceeded. Note that the payloads include anything added to the bare chassis, as well as the weight of all AEM attachments.

725 SWB with hoist 352-1747								
	Front		Center		Rear		Total	
	kg	lb	kg	lb	kg	lb	kg	lb
Empty	12 850	28,330	3190	7,040	2770	6,110	18 810	41,470
Rated Load	2180	4,810	12 430	27,410	12 430	27,410	27 040	59,620
Loaded	15 030	33,140	15 620	34,440	15 200	33,520	45 850	101,090
725 SWB no hoist 199-4107								
	Front		Center		Rear		Total	
	kg	lb	kg	lb	kg	lb	kg	lb
Empty	12 710	28,030	3090	6,820	2670	5,890	18 470	40,720
Rated Load	2320	5,120	12 530	27,630	12 530	27,630	27 380	60,370
Loaded	15 030	33,140	15 620	34,440	15 200	33,520	45 850	101,090
725 LWB with hoist 199-4115								
	Front		Center		Rear		Total	
	kg	lb	kg	lb	kg	lb	kg	lb
Empty	13 490	29,750	3310	7,300	2890	6,380	19 690	43,410
Rated Load	1540	3,400	12 310	27,140	12 310	27,140	26 160	57,680
Loaded	15 030	33,140	15 620	34,440	15 200	33,520	45 850	101,090
725 LWB no hoist 199-4111								
	Front		Center		Rear		Total	
	kg	lb	kg	lb	kg	lb	kg	lb
Empty	13 270	29,260	3100	6,840	2680	5,910	19 050	42,000
Rated Load	1760	3,890	12 520	27,610	12 520	27,610	26 800	59,090
Loaded	15 030	33,140	15 620	34,440	15 200	33,520	45 850	101,090
730 SWB with hoist 294-3209								
	Front		Center		Rear		Total	
	kg	lb	kg	lb	kg	lb	kg	lb
Empty	12 920	28,490	3260	7,190	2970	6,550	19 150	42,220
Rated Load	2940	6,490	14 440	31,840	14 440	31,840	31 820	70,160
Loaded	15 860	34,970	17 700	39,030	17 410	38,390	50 970	112,370
730 SWB no hoist 199-4108								
	Front		Center		Rear		Total	
	kg	lb	kg	lb	kg	lb	kg	lb
Empty	12 730	28,070	3220	7,100	2800	6,180	18 750	41,340
Rated Load	3130	6,910	14 480	31,930	14 610	32,210	32 220	71,040
Loaded	15 860	34,970	17 700	39,030	17 410	38,390	50 970	112,370
730 LWB with hoist 199-4116								
	Front		Center		Rear		Total	
	kg	lb	kg	lb	kg	lb	kg	lb
Empty	13 600	29,990	3540	7,810	3200	7,060	20 340	44,850
Rated Load	2260	4,990	14 160	31,220	14 210	31,330	30 630	67,530
Loaded	15 860	34,970	17 700	39,030	17 410	38,390	50 970	112,370
730 LWB no hoist 199-4112								
	Front		Center		Rear		Total	
	kg	lb	kg	lb	kg	lb	kg	lb
Empty	13 370	29,480	3370	7,430	3030	6,690	19 740	43,520
Rated Load	2490	5,490	14 330	31,600	14 380	31,710	31 230	68,860
Loaded	15 860	34,970	17 700	39,030	17 410	38,390	50 970	112,370

Machine Operating Weights (continued)

735 SWB with hoist								
	Front		Center		Rear		Total	
	kg	lb	kg	lb	kg	lb	kg	lb
Empty	18 500	40,790	4600	10,150	3900	8,600	27 000	59,530
Rated Load	3800	8,380	16 600	36,600	16 600	36,600	37 000	81,580
Loaded	22 300	49,170	21 200	46,740	20 500	45,200	64 000	141,100
735 SWB no hoist 283-6343								
	Front		Center		Rear		Total	
	kg	lb	kg	lb	kg	lb	kg	lb
Empty	18 400	40,570	4500	9,930	3800	8,380	26 700	58,870
Rated Load	3900	8,600	16 700	36,820	16 700	36,820	37 300	82,240
Loaded	22 300	49,170	21 200	46,740	20 500	45,200	64 000	141,100
735 LWB with hoist 199-4117								
	Front		Center		Rear		Total	
	kg	lb	kg	lb	kg	lb	kg	lb
Empty	18 100	39,910	5400	11,910	4700	10,370	28 200	62,180
Rated Load	4200	9,260	15 800	34,840	15 800	34,840	35 800	78,930
Loaded	22 300	49,170	21 200	46,740	20 500	45,200	64 000	141,100
735 LWB no hoist 199-4113								
	Front		Center		Rear		Total	
	kg	lb	kg	lb	kg	lb	kg	lb
Empty	17 900	39,470	5200	11,470	4500	9,930	27 600	60,850
Rated Load	4400	9,710	16 000	35,280	16 000	35,280	36 400	80,250
Loaded	22 300	49,170	21 200	46,740	20 500	45,200	64 000	141,100
740 SWB with hoist								
	Front		Center		Rear		Total	
	kg	lb	kg	lb	kg	lb	kg	lb
Empty	18 900	41,670	4900	10,810	4200	9,260	28 000	61,730
Rated Load	5700	12,570	19 450	42,880	19 450	42,880	44 600	98,330
Loaded	24 600	54,240	24 350	53,690	23 650	52,140	72 600	160,060
740 SWB no hoist 209-2224								
	Front		Center		Rear		Total	
	kg	lb	kg	lb	kg	lb	kg	lb
Empty	18 700	41,230	4800	10,590	4100	9,040	27 600	60,850
Rated Load	5900	13,010	19 550	43,110	19 550	43,110	45 000	99,210
Loaded	24 600	54,240	24 350	53,690	23 650	52,140	72 600	160,060
740 LWB with hoist 199-4118								
	Front		Center		Rear		Total	
	kg	lb	kg	lb	kg	lb	kg	lb
Empty	19 200	42,330	5400	11,910	4600	10,150	29 200	64,380
Rated Load	5400	11,910	18 950	41,780	19 050	42,000	43 400	95,690
Loaded	24 600	54,240	24 350	53,690	23 650	52,140	72 600	160,060
740 LWB no hoist 199-4114								
	Front		Center		Rear		Total	
	kg	lb	kg	lb	kg	lb	kg	lb
Empty	18 950	41,780	5200	11,470	4500	9,930	28 650	63,170
Rated Load	5650	12,460	19 150	42,220	19 150	42,220	43 950	96,900
Loaded	24 600	54,240	24 350	53,690	23 650	52,140	72 600	160,060

Machine Dimensions

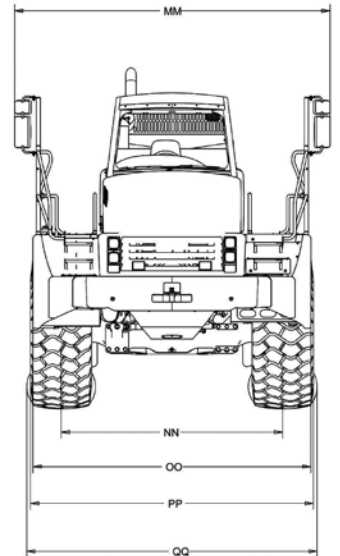
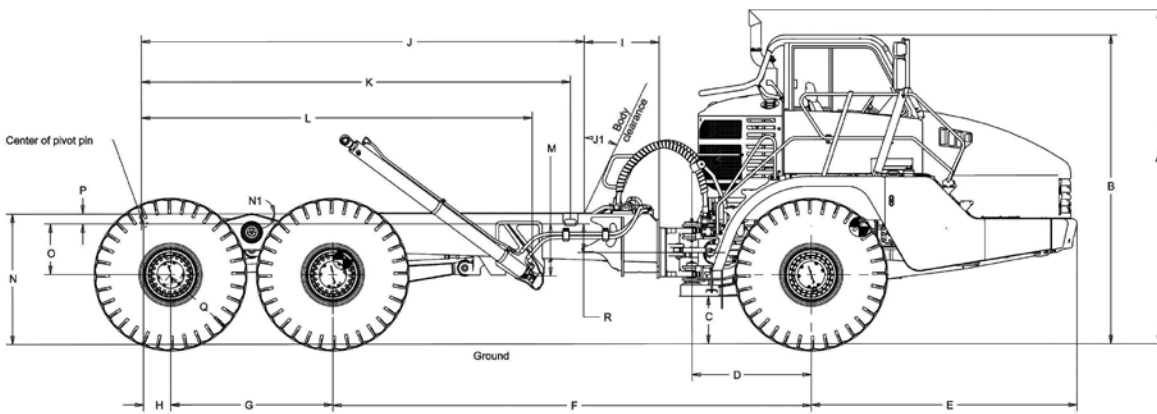
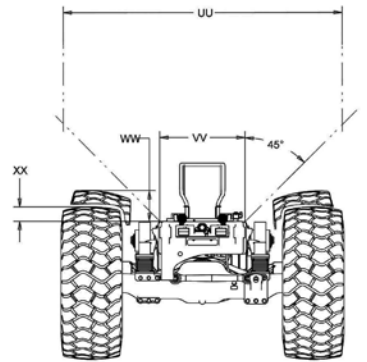
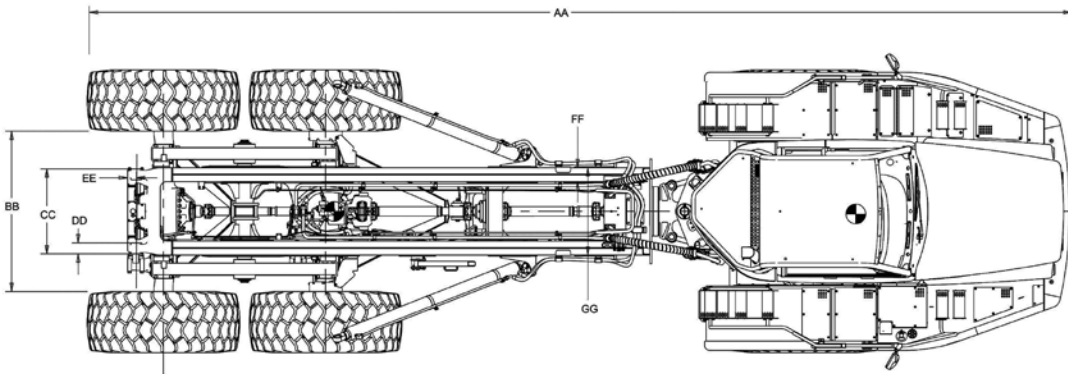

Machine Dimensions

Dim.	Description	725				730				735				740				EJ	
		SWB		LWB		SWB		LWB		SWB		LWB		SWB		LWB		mm	ft
		mm	ft	mm	ft	mm	ft	mm	ft	mm	ft	mm	ft	mm	ft				
A	Exhaust stack	3751	12.31	3751	12.31	3751	12.31	3751	12.31	4006	13.14	4006	13.14	4049	13.28	4049	13.28	4049	13.28
B	Top of cab	3440	11.29	3440	11.29	3440	11.29	3440	11.29	3703	12.15	3703	12.15	3745	12.29	3745	12.29	3745	12.29
C	Clearance	495	1.62	495	1.62	495	1.62	495	1.62	534	1.75	534	1.75	577	1.89	577	1.89	577	1.89
D	Articulation joint to front axle	1175	3.85	1175	3.85	1175	3.85	1175	3.85	1451	4.76	1451	4.76	1451	4.76	1451	4.76	1451	4.76
E	Front axle to bumper	2721	8.93	2721	8.93	2721	8.93	2721	8.93	3221	10.57	3221	10.57	3221	10.57	3221	10.57	3221	10.57
F	Front axle to center axle	3818	12.53	5305	17.40	3818	12.53	5305	17.40	4244	13.92	5800	19.03	4244	13.92	5800	19.03	4596	15.08
G	Center axle to rear axle	1700	5.58	1700	5.58	1700	5.58	1700	5.58	1966	6.45	1966	6.45	1966	6.45	1966	6.45	1966	6.45
H	Rear axle to pivot pin center	545	1.79	545	1.79	545	1.79	545	1.79	328	1.08	328	1.08	328	1.08	328	1.08	328	1.08
I	Body clearance	804	2.64	804	2.64	804	2.64	804	2.64	894	2.93	875	2.87	894	2.93	875	2.87	894	2.93
J	Body clearance	3725	12.22	5211	17.10	3725	12.22	5211	17.10	3800	12.47	5375	17.63	3800	12.47	5375	17.63	4152	13.62
J1	Front body angle	25°	25°	25°	25°	25°	25°	25°	25°	25°	25°	25°	25°	25°	25°	25°	25°	25°	25°
K	Body guides	3600	11.81	5066	16.62	3600	11.81	5066	16.62	3774	12.38	5175	16.98	3774	12.38	5175	16.98	3685	12.09
L	Hoist mount*	4398	14.43	4682	15.36	4398	14.43	4682	15.36	4470	14.67	4696.5	15.41	4470	14.67	4696.5	15.41	NA	NA
M	Hoist mount*	446	1.46	616	2.02	446	1.46	616	2.02	255	0.84	655.1	2.15	255	0.84	655.1	2.15	NA	NA
N	Top of frame rail	1436	4.71	1436	4.71	1436	4.71	1436	4.71	1573	5.16	1573	5.16	1626	5.33	1626	5.33	1626	5.33
N1	Top of frame angle	2°	2°	0°	0°	2°	2°	0°	0°	2°	2°	0°	0°	2°	2°	0°	0°	2°	2°
O	Rear axle to pivot pin center	623	2.04	623	2.04	623	2.04	623	2.04	615	2.02	615	2.02	615	2.02	615	2.02	615	2.02
P	Pivot pin to top of frame rail	78	0.26	78	0.26	78	0.26	78	0.26	123	0.40	123	0.40	123	0.40	123	0.40	138	0.45
Q	Tire radius	803	2.63	803	2.63	803	2.63	803	2.63	870	2.85	870	2.85	925	3.03	925	3.03	925	3.03
R	Oscillation center to pivot pin	363	1.19	363	1.19	363	1.19	363	1.19	345	1.13	345	1.13	345	1.13	345	1.13	345	1.13
AA	Machine length	9068	29.75	10554	34.63	9068	29.75	10554	34.63	10301	33.80	11856	38.90	10355	33.97	11911	39.08	10707	35.13
BB	Tire clearance	1626	5.33	1626	5.33	1626	5.33	1626	5.33	2021	6.63	2021	6.63	1944	6.38	1944	6.38	1944	6.38
CC	Pivot casting width	835	2.74	835	2.74	835	2.74	835	2.74	1031	3.38	1031	3.38	1031	3.38	1031	3.38	1031	3.38
DD	Pivot bearing width	135	0.44	135	0.44	135	0.44	135	0.44	134	0.44	134	0.44	134	0.44	134	0.44	134	0.44
EE	Pivot pin to rear of frame	65	0.21	65	0.21	65	0.21	65	0.21	107	0.35	107	0.35	107	0.35	107	0.35	107	0.35
FF	Beam width	162	0.53	162	0.53	162	0.53	162	0.53	170	0.56	170	0.56	170	0.56	170	0.56	170	0.56
GG	Frame width	860	2.82	860	2.82	860	2.82	860	2.82	1060	3.48	1060	3.48	1060	3.48	1060	3.48	1060	3.48
HH	Hoist mount*	516	1.69	549	1.80	516	1.69	549	1.80	650	2.13	650.7	2.13	650	2.13	650.7	2.13	NA	NA
MM	Mirror width	3645	11.96	3645	11.96	3645	11.96	3645	11.96	3823	12.54	3823	12.54	3823	12.54	3823	12.54	3823	12.54
NN	Tire centerline	2275	7.46	2275	7.46	2275	7.46	2275	7.46	2687	8.82	2687	8.82	2687	8.82	2687	8.82	2687	8.82
OO	Fender width	2800	9.19	2800	9.19	2800	9.19	2800	9.19	3370	11.06	3370	11.06	3370	11.06	3370	11.06	3370	11.06
PP	Free width of tire	2877	9.44	2877	9.44	2877	9.44	2877	9.44	3353	11.00	3353	11.00	3430	11.25	3430	11.25	3430	11.25
QQ	Tire bulge	2950	9.68	2950	9.68	2950	9.68	2950	9.68	3434	11.27	3434	11.27	3520	11.55	3520	11.55	3520	11.55
UU	Body width	2902	9.52	2902	9.52	2902	9.52	2902	9.52	3418	11.21	3418	11.21	3418	11.21	3418	11.21	3483	11.43
VV	Body pivot clearance	840	2.76	840	2.76	840	2.76	840	2.76	1034	3.39	1034	3.39	1034	3.39	1034	3.39	1034	3.39
WW	Axle oscillation tire clearance	283	0.93	283	0.93	283	0.93	283	0.93	323	1.06	323	1.06	375	1.23	375	1.23	375	1.23
XX	Tire clearance	99	0.32	99	0.32	99	0.32	99	0.32	121	0.40	121	0.40	175	0.57	175	0.57	175	0.57

*LWB machines ordered without hoist cylinders do not have frame hoist mounting

Center of Gravity

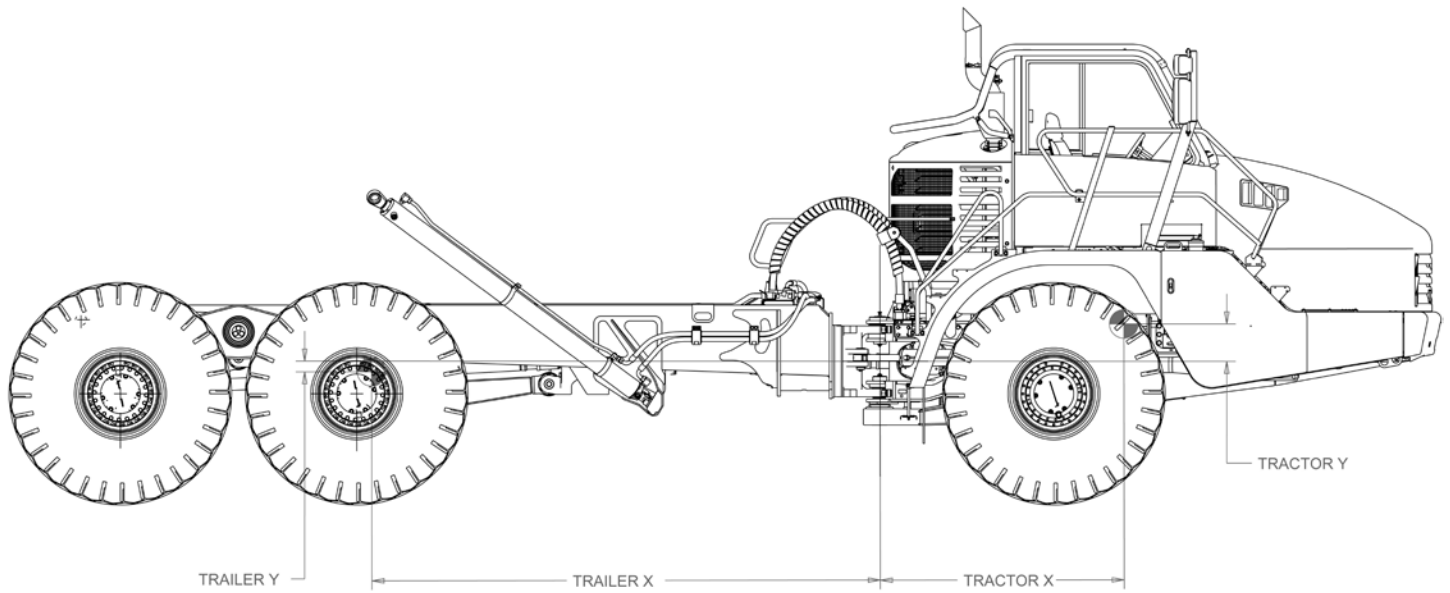
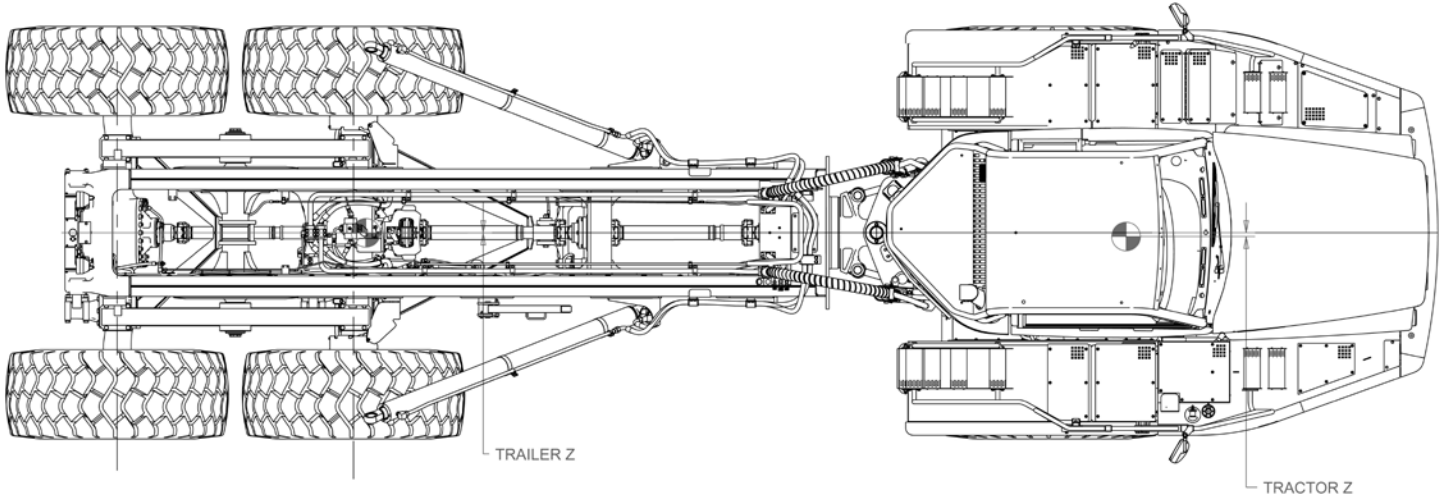

Center of Gravity

	WEIGHT		X		Y		Z			WEIGHT		X		Y		Z	
	kg	lb	mm	in	mm	in	mm	in		kg	lb	mm	in	mm	in	mm	in
725 AT 226-8615									730 AT 226-8616								
Tractor	10 580	23,330	1674	65.9	300	11.8	10	0.4	Tractor	10 628	23,430	1673	65.88	298	11.73	8	0.31
Trailer	11 575	25,520	-2977	-117.2	-38	-1.5	1	0.0	Trailer	12 116	26,720	-2983	-117.44	44	1.72	-2	-0.08
AT	22 154	48,850	-756	-29.8	123	4.9	5	0.2	AT	22 743	50,150	-807	-31.78	163	6.40	3	0.10
Body	3462	7,640	-3252	-128.0	985	38.8	0	0.0	Body	3720	8,210	-3207	-126.26	1035	40.76	0	0.00
Payload	23 590	52,010	-3096	-121.9	1365	53.7	0	0.0	Payload	28 120	62,000	-3043	-119.81	1457	57.36	0	0.00
Body & Payload	27 052	59,640	-3116	-122.7	1316	51.8	0	0.0	Body & Payload	31 840	70,200	-3062	-120.56	1408	55.42	0	0.00
725 SWB with hoist 352-1747									730 SWB with hoist 294-3209								
Tractor	10 580	23,330	1674	65.9	300	11.8	10	0.4	Tractor	10 628	23,430	1673	65.9	298	11.7	8	0.3
Trailer	8113	17,890	-2860	-112.6	-475	-18.7	1	0.0	Trailer	8396	18,510	-2888	-113.7	-393	-15.5	-3	-0.1
AT BC	18 692	41,210	-294	-11.6	-36	-1.4	6	0.2	AT BC	19 023	41,940	-340	-13.4	-7	-0.3	3	0.1
725 SWB no hoist 199-4107									730 SWB no hoist 199-4108								
Tractor	10 580	23,330	1674	65.9	300	11.8	10	0.4	Tractor	10 628	23,430	1673	65.9	298	11.7	8	0.3
Trailer	7773	17,140	-2912	-114.7	-517	-20.4	1	0.1	Trailer	8013	17,670	-2948	-116.1	-435	-17.1	-3	-0.1
AT BC	18 352	40,470	-268	-10.6	-46	-1.8	6	0.2	AT BC	18 640	41,100	-313	-12.3	-17	-0.7	3	0.1
725 LWB with hoist 199-4115									730 LWB with hoist 199-4116								
Tractor	10 580	23,330	1674	65.9	300	11.8	10	0.4	Tractor	10 628	23,430	1673	65.9	298	11.7	8	0.3
Trailer	9022	19,890	-3955	-155.7	-71	-2.8	-2	-0.1	Trailer	9551	21,060	-3987	-157.0	-17	-0.7	-5	-0.2
AT BC	19 601	43,220	-917	-36.1	129	5.1	4	0.2	AT BC	20 178	44,490	-1006	-39.6	149	5.9	2	0.1
725 LWB no hoist 199-4111									730 LWB no hoist 199-4112								
Tractor	10 580	23,330	1674	65.9	300	11.8	10	0.4	Tractor	10 628	23,430	1673	65.9	298	11.7	8	0.3
Trailer	8396	18,510	-4036	-158.9	-103	-4.1	-3	-0.1	Trailer	8916	19,660	-4052	-159.5	-46	-1.8	-7	-0.3
AT BC	18 975	41,840	-852	-33.6	121	4.8	4	0.2	AT BC	19 543	43,090	-939	-37.0	141	5.5	1	0.0
735 AT 226-8617									740 AT 226-8618								
Tractor	15 479	34,130	2042	80.4	324	12.8	33	1.3	Tractor	15 820	34,880	2029	79.9	311	12.3	32	1.3
Trailer	15 934	35,130	-3149	-124.0	243	9.6	2	0.1	Trailer	17 332	38,210	-3143	-123.7	281	11.1	2	0.1
AT	31 412	69,260	-591	-23.3	283	11.1	17	0.7	AT	33 151	73,090	-675	-26.6	295	11.6	16	0.6
Body	4463	9,840	-3289	-129.5	1097	43.2	0	0.0	Body	5177	11,420	-3173	-124.9	1175	46.3	0	0.0
Payload	32 700	72,100	-3236	-127.4	1547	60.9	0	0.0	Payload	39 500	87,090	-3091	-121.7	1658	65.3	0	0.0
Body & Payload	37 163	81,940	-3242	-127.7	1493	58.8	0	0.0	Body & Payload	44 677	98,500	-3100	-122.1	1602	63.1	0	0.0
735 SWB with hoist									740 SWB with hoist								
Tractor	15 479	34,130	2042	80.4	324	12.8	33	1.3	Tractor	15 820	34,880	2029	79.9	311	12.3	32	1.3
Trailer	11 471	25,290	-3099	-122.0	-89	-3.5	3	0.1	Trailer	12 155	26,800	-3134	-123.4	-100	-3.9	2	0.1
AT BC	26 949	59,420	-146	-5.8	148	5.8	20	0.8	AT BC	27 974	61,680	-215	-8.4	133	5.2	19	0.8
735 SWB no hoist 283-6343									740 SWB no hoist 209-2224								
Tractor	15 479	34,130	2042	80.4	324	12.8	33	1.3	Tractor	15 820	34,880	2029	79.9	311	12.3	32	1.3
Trailer	11 048	24,360	-3146	-123.9	-119	-4.7	3	0.1	Trailer	11 730	25,860	-3183	-125.3	-127	-5.0	3	0.1
AT BC	26 526	58,490	-119	-4.7	140	5.5	20	0.8	AT BC	27 549	60,740	-190	-7.5	125	4.9	20	0.8
735 LWB with hoist 199-4117									740 LWB with hoist 199-4118								
Tractor	15 479	34,130	2042	80.4	324	12.8	33	1.3	Tractor	15 820	34,880	2029	79.9	311	12.3	32	1.3
Trailer	12 613	27,810	-4184	-164.7	-83	-3.3	1	0.0	Trailer	13 297	29,320	-4241	-167.0	-93	-3.7	1	0.0
AT BC	28 091	61,940	-754	-29.7	141	5.6	19	0.7	AT BC	29 116	64,200	-834	-32.8	127	5.0	18	0.7
735 LWB no hoist 199-4113									740 LWB no hoist 199-4114								
Tractor	15 479	34,130	2042	80.4	324	12.8	33	1.3	Tractor	15 820	34,880	2029	79.9	311	12.3	32	1.3
Trailer	12 027	26,520	-4249	-167.3	-94	-3.7	0	0.0	Trailer	12 709	28,020	-4308	-169.6	-104	-4.1	0	0.0
AT BC	27 505	60,640	-709	-27.9	141	5.6	19	0.7	AT BC	28 528	62,900	-794	-31.3	126	5.0	18	0.7

Notes: All weights are unloaded machine, full of fluids, without an operator
 All dimensions are from the center of the oscillation and articulation joint
 Tractor – the machine weight in front of the articulation joint
 Trailer – the machine weight behind the articulation joint
 AT – weight of a complete articulated truck with the standard dirt dump body
 AT BC – weight of the AT Bare Chassis without body or payload

Hydraulic Specifications

Many applications will require hydraulic power. The easiest source of hydraulic power on AT bare chassis is to use the hoist circuit. All bare chassis, whether equipped with hoist cylinders or not, will come with the hoist control lever in the cab, the hoist control valve, and hydraulic line to the manifold block on the back side of the articulation joint. On 735 and 740 machines, the hoist oil is also used for brake cooling. To prevent brake-heating issues, the hoist oil must be returned to the hoist valve and not returned to tank.

Hoist Cylinder Specifications								
	725		730		735		740	
Part Number	285-4031		285-4032		285-4033		285-4034	
Bore Diameter	114.3 mm	4.5 in	127 mm	5 in	127 mm	5 in	139.7 mm	5.5 in
Rod Diameter	76.2 mm	3 in	76.2 mm	3 in	88.9 mm	3.5 in	88.9 mm	3.5 in
Stroke	2332 mm	91.8 in	2332 mm	91.8 in	2420 mm	95.3 in	2411 mm	95.3 in
Pin-to-Pin Length								
Closed	2837 mm	111.7 in	2837 mm	111.7 in	2925 mm	115.2 in	2925 mm	115.2 in
Open	5169 mm	203.5 in	5169 mm	203.5 in	5345 mm	210.4 in	5336 mm	210.1 in
Port Size	SAE 12		SAE 12		SAE 16		SAE 16	
Pin Size	57.15 mm	2.3 in	57.15 mm	2.3 in	57.15 mm	2.3 in	57.15 mm	2.3 in
Hoist Circuit Specifications								
Relief Pressure								
Up	20 700 kPa	3,000 psi	20 700 kPa	3,000 psi	22 500 kPa	3,260 psi	22 500 kPa	3,260 psi
Down	6900 kPa	1,000 psi	6900 kPa	1,000 psi	6900 kPa	1,000 psi	6900 kPa	1,000 psi
Pump Flow @ 2050	298 L/min	79 GPM	298 L/min	79 GPM	323 L/min	85 GPM	386 L/min	85 GPM
Pump Flow @ 700 rpm					134 L/min	35 GPM	134 L/min	35 GPM
Pump Type	Variable Displacement				Fixed Displacement			
Tank Volume	100 L	26 Gal	100 L	26 Gal	225 L	59 Gal	225 L	59 Gal

There are additional pump drive locations available on the 725 and 730 ATs. For locations and specification of these drives, contact OEM Solutions. On the 735 and 740, there are no open pump-mounting locations available. For custom hydraulic information, including electronic controls (levers, switches and software), valves and pumps, contact OEM Solutions.

General AT Bare Chassis Welding Tips

For the best, safest results...on the rear AT machine frame:

1. Don't weld on the top and bottom surfaces of the frame rail.
2. Weld attachment on the sides of the frame as close as possible to the horizontal center line of the frame rail.
3. Keep a safe distance from the existing plate welded on the side of the frame rails (usually a stressed area already).
4. Weld parallel to the frame rails and not across the frame rail.

Suggested Cat part numbers to use as reference for welded attachments

For part illustrations and specifications, log onto <https://epix.cat.com/epix/index.do>.

This is a secure website. If you do not have access, contact your OEM Solutions Group representative.

To attach large structures:

- 178-6165
- 155-5744
- 185-5611
- 150-3906

To mount small structures and attachments:

- 191-5187
- 191-5188
- 191-5189
- 165-6856

To secure tubes, hoses, wiring harnesses and other light components:

- 177-2989
- 146-2533
- 245-4520
- 149-0733

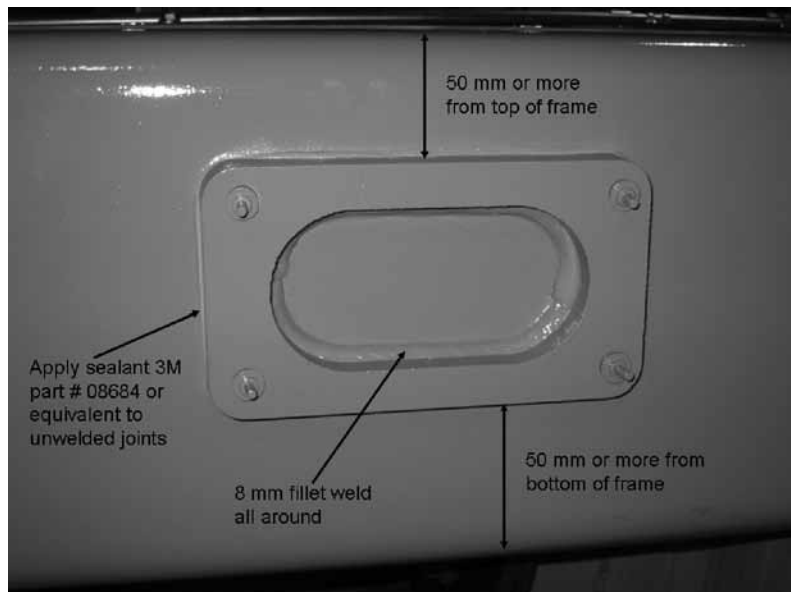

AT Tire Options

There are a number of different tire options available for AT trucks. In some cases, tires not in the price list may be ordered and factory installed (availability may be limited and subject to change). For more information, contact your Caterpillar OEM Solutions Group representative.

Available Body Parts

The following Cat AT parts are frequently requested for use on AT-based custom machines. Contact OEM Solutions Group for assistance to identify Cat parts that complement and support OEM attachments.

Part #	Qty.	Name	Description
Hoist Mounting			
141-4076	1	BRACKET-HOIST LH	Left-hand body hoist mounting casting
141-4077	1	BLOCK-HOIST RH	Right-hand body hoist mounting casting
Rubber Pads			
140-8227	4 to 8	BUFFER-RUBBER	body to frame pads
142-0534	12 to 24	SHIM	3 mm shim for body pads
142-0535	4 to 8	SHIM	8 mm shim for body pads
Body Pivot Pins			
142-1227	2	PIN AS.-DUMP	pivot pins
5U-0297	6	SHIM	shim for pivot pins
144-6952	2	BUSH	pivot pin mounting spacer
Body Guides			
140-8226	2	GUIDE AS.	725 and 730 body guides
308-1795	1	PLATE AS.-GUIDE	735 left-hand body guide
308-1796	1	PLATE AS.-GUIDE	735 right-hand body guide
155-7877	2	PLATE AS.-GUIDE	740 body guides
142-0536	4	SHIM	3 mm shim for body guide
142-0537	2	SHIM	8 mm shim for body guide

For part illustrations and specifications, log onto <https://epix.cat.com/epix/index.do>. This is a secure website. If you do not have access, contact your OEM Solutions Group representative.

ROPS

The AT ROPS is certified to the maximum weights listed below, per ISO 3471 Class 4. The ROPS weights for articulated trucks are based only on the tractor (forward of the articulation joint) weight. If any weight is added to the AT tractor portion, care must be taken to ensure that the ROPS weight is not exceeded.

AT ROPS Limitations	
Based on ROPS Standard ISO 3471:1994 (Tractors)	
Model	Weight Limit
725	15 176 kg (33,387 lb)
730 & 730 EJ	15 176 kg (33,387 lb)
735	16 133 kg (35,493 lb)
740 & 740 EJ	16 133 kg (35,493 lb)

Turning Radius

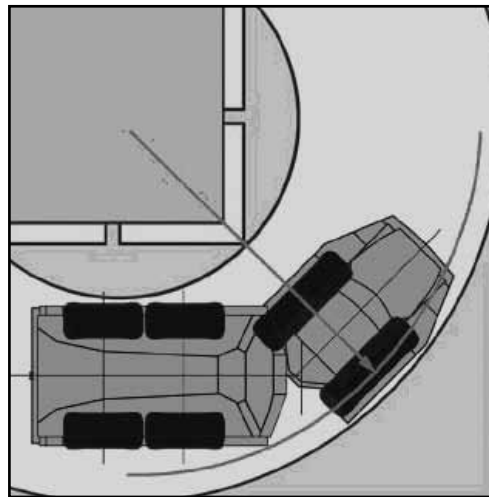

AT Long Wheel Base Turning Radius								
Model	725 LWB		730 LWB		735 LWB		740 LWB	
Tires	23.5R25		23.5R25		26.5R25		29.5R25	
Steer angle left/right	45°		45°		45°		45°	
SAE turning radius	9355 mm	30.69 ft	9355 mm	30.69 ft	10 340 mm	33.92 ft	10 340 mm	33.92 ft
Clearance radius	9680 mm	31.76 ft	9680 mm	31.76 ft	10 750 mm	35.27 ft	10 750 mm	35.27 ft
Inside radius	5196 mm	17.05 ft	5196 mm	17.05 ft	5660 mm	18.57 ft	5710 mm	18.73 ft
Aisle width	6006 mm	19.70 ft	6006 mm	19.70 ft	6750 mm	22.15 ft	6710 mm	22.01 ft

Note: For SWB turning radius, refer to specalog for standard AT with dump body. These specifications are available at www.cat.com.

AT Bare Chassis Reference Material

A wide range of AT bare chassis technical specifications and reference material is available on-line at www.cat.com/oemsolutions, including many of the media numbers listed here.

Sales Model	OEMSG Direct Mail	OEMSG Sell Sheet	Industry Brochure	OMM
725	WEDQ1016	WEDQ1014	WEDQ1017	SEBU7814
730				SEBU7815
735				
740				

For more information on Cat Bare Chassis Articulated Trucks, including service-related materials, contact your Cat Dealer or OEM Solutions representative.

Materials and specifications are subject to change without notice.

WEGQ1002-01

© 2010 Caterpillar • All Rights Reserved • Printed in USA
CAT, CATERPILLAR, their respective logos, "Caterpillar Yellow" and the "Power Edge" trade dress, as well as corporate and product identity used herein, are trademarks of Caterpillar and may not be used without permission.

