

735B

Articulated Truck

The new Cat® 735B with 32.7 tonnes (36 tons) rated payload offers proven reliability and durability, high productivity, superior operator comfort and lower operating costs.

The spacious two-person cab with forward facing passenger seat and off road oil/nitrogen front suspension cylinders keep the operator comfortable through out the working day.

The true “on-the-go” Automatic Traction Control (ATC) system automatically modulates the correct level of Inter-Axle and Cross-Axle differential lock engagement which will improve cycle times and productivity. No operator interaction is required.

The strong, durable Cat ACERT™ engines with the Tier 2/Stage II exhaust emission solution and electronically controlled smooth shifting transmissions deliver high productivity with low fuel consumption. There are significant changes/improvements to the engine/transmission software that result in smoother gear changes.



New Features

C15 Engine with ACERT™ Technology meeting Tier 2/EU Stage II engine emission regulations

Controlled Throttle Shift (CTS) Transmission

Automatic Traction Control (ATC)

Passenger grab handles

Floor-mounted accelerator pedal

Park brake switch – guarded by raised dash moldings

Dash dimmer switch

Headliner with radio mounting

Machine width position lamps

Electric hood switch mounted in-cab

External grab rail around cab roof

Improved fuse panel

Color Multi-Purpose Display (CMPD) incorporating the rearview camera screen and cycle counter

Machine Security System Tornado-ready (optional)

External roof-level work lights (optional)

Motorized heated mirrors (optional)



735B Articulated Truck Specifications

Engine

Engine Model	Cat® C15 ACERT™	
Gross Power – SAE J1995	336 kW	450 hp
Net Power – SAE J1349	326 kW	438 hp
Net Power – ISO 9249	330 kW	442 hp
Net Power – EEC 80/1269	330 kW	442 hp
Bore	137 mm	5.4 in
Stroke	171.5 mm	6.75 in
Displacement	15.2 L	926 in ³

- The power ratings apply at rated speed of 1,800 rpm when tested under the conditions for the specified standard.
- The net power advertised is the power available at the flywheel when the engine is equipped with alternator, air cleaner, muffler and fan at minimum speed.
- Net power when the fan is at maximum speed is 296 kW (397 hp) per the SAE reference conditions.
- The 735B meets EPA Tier 2/EU Stage II emission specifications for U.S. and Europe through 2013.
- No engine derating required below 3650 m (12,000 ft).
- Peak engine torque gross (SAE J1995) 2312 N-m (1,705 lb-ft).
- Peak engine torque net (SAE J1349) 2264 N-m (1,670 lb-ft).
- Peak engine torque speed (rpm) 1,200.

Weights

Rated Payload	32.7 tonnes	36 tons
---------------	-------------	---------

Body Capacities

Heaped SAE 2:1	19.7 m ³	25.8 yd ³
Struck	14.7 m ³	19.2 yd ³
Tailgate Heaped SAE 2:1	20.9 m ³	27.3 yd ³
Tailgate Struck	15.2 m ³	19.9 yd ³

Transmission

Forward 1	8.3 km/h	5.1 mph
Forward 2	11.3 km/h	7 mph
Forward 3	15.3 km/h	9.5 mph
Forward 4	20.6 km/h	12.8 mph
Forward 5	27.3 km/h	17 mph
Forward 6	37.7 km/h	23.4 mph
Forward 7	51.1 km/h	31.8 mph
Reverse 1	8 km/h	5 mph
Reverse 2	10.8 km/h	6.7 mph

Sound Levels

Interior Cab	79 dB(A)
--------------	----------

- The operator sound exposure Leq (equivalent sound pressure level) measured according to the work cycle procedures specified in ANSI/SAE J1166 OCT 98 is 79 dB(A), for the cab offered by Caterpillar, when properly installed and maintained and tested with the doors and windows closed.
- Hearing protection may be needed when operating with an open operator station and cab (when not properly maintained or doors/windows open) for extended periods or in noisy environments.

Operating Weights

Front Axle – Empty	19 716 kg	43,466 lb
Center Axle – Empty	6610 kg	14,573 lb
Rear Axle – Empty	5881 kg	12,965 lb
Total – Empty	32 206 kg	71,002 lb
Front Axle – Rated Load	3371 kg	7,432 lb
Center Axle – Rated Load	14 664 kg	32,329 lb
Rear Axle – Rated Load	14 664 kg	32,329 lb
Total – Rated Load	32 700 kg	72,091 lb
Front Axle – Loaded	23 087 kg	50,898 lb
Center Axle – Loaded	21 274 kg	46,901 lb
Rear Axle – Loaded	20 545 kg	45,294 lb
Total – Loaded	64 906 kg	143,093 lb

Body Plate Thickness

Front	8 mm	0.31 in
Scow	16 mm	0.63 in
Side	12 mm	0.47 in
Base	16 mm	0.63 in

Service Refill Capacities

Fuel Tank	565 L	149.3 gal
Cooling System	96 L	25.4 gal
Hydraulic System	330 L	87.2 gal
Engine Crankcase	40 L	10.6 gal
Transmission	85 L	22.5 gal
Final Drives/Differential	230 L	60.8 gal
Output Transfer Gear Box	22 L	5.8 gal

Body Hoist

Raise time	11 Seconds
Lower time	7 Seconds

Standards

Brakes	ISO 3450 – 1996
Cab/FOPS	ISO 3449 Level II – 2005
Cab/ROPS	ISO 3471 – 2008
Steering	ISO 5010 – 2007

735B Articulated Truck Specifications

Dimensions

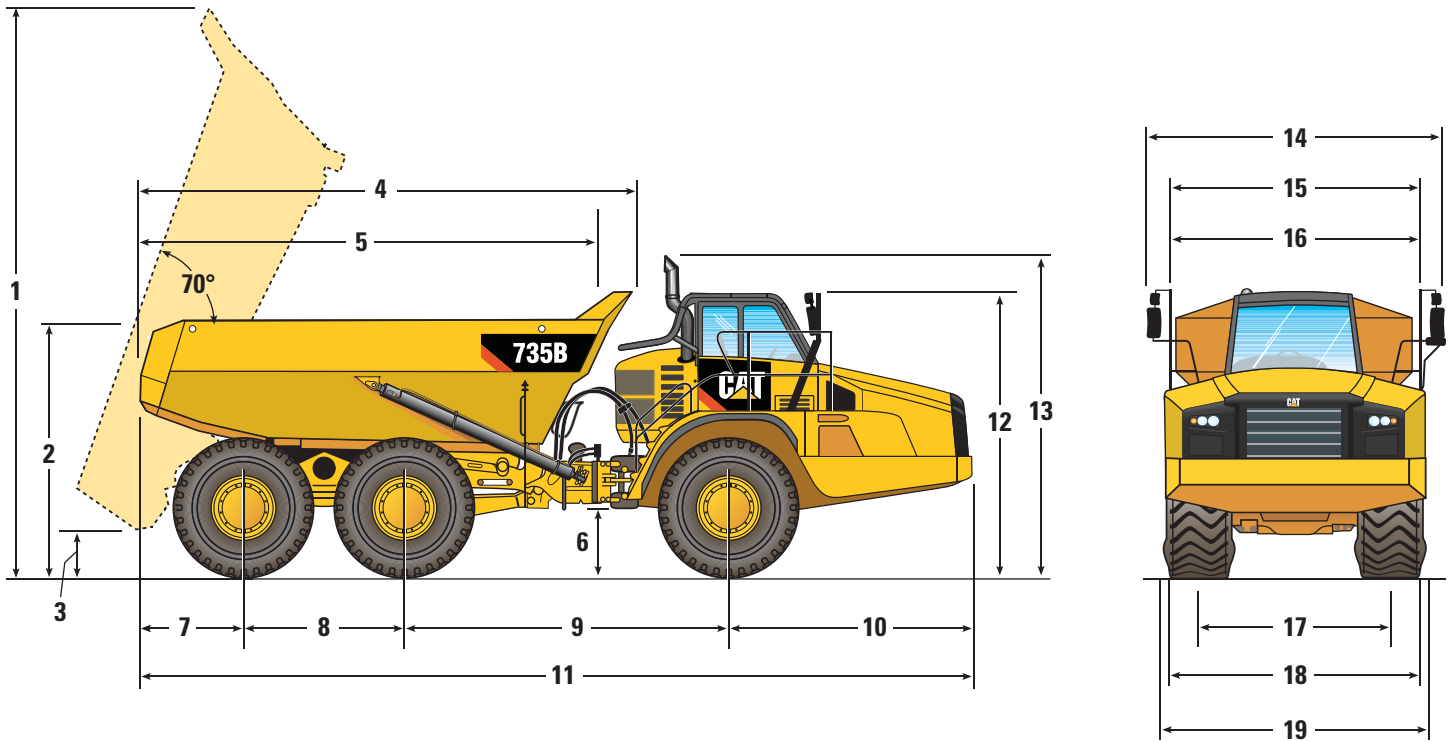

	mm	ft
1	6809	22.3
2	2982	9.8
3	635	2.0
4	6088	20.0
5*	5467	17.9
6	534	1.7
7	1458	4.7
8	1966	6.4
9	4246	13.9
10	3330	10.9

	mm	ft
11	11 000	36.1
12	3702	12.1
13**	3996	13.1
14	4160	13.6
15***	3690	12.1
16	3328	10.9
17	2687	8.8
18	3366	11.0
19****	3441	11.3

*Inside of body.

**Exhaust stack can be removed for transportation.

***If equipped with a scissor tailgate.

****Max-unladen over tire bulge.

735B Articulated Truck Specifications

Turning Circle

Dimensions are for machines equipped with 26.5R25 tires.

Turning dimensions

Steer angle – left/right	45°	
SAE turning radius	8138 mm	320.4 in
Clearance radius	8595 mm	338.4 in
Inside radius	4182 mm	164.7 in
Aisle width	5637 mm	221.9 in

Steering

Lock to Lock

4.6 seconds @ 60 rpm

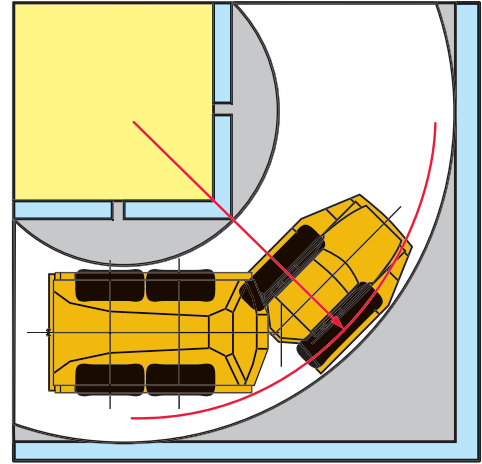

Optimal Loader/Truck Pass Matching

Hydraulic Excavators	385C	365C	345D
Loader Capacity (Tonnes) – 50 min hr	954-1193	750-1100	665-805
Loader Capacity (Tons) – 50 min hr	1,049-1,314	825-1,210	735-885
Passes	3	4	5

Wheel Loaders	988H	980H	972H	966H	962H
Loader Capacity (Tonnes) – 50 min hr	565-790	590-650	490-565	400-535	325-400
Loader Capacity (Tons) – 50 min hr	625-870	650-715	540-625	440-590	360-440
Passes	3	3-4	4-5	5	6

An optimum system match gives you a major productivity advantage. The 735B is an excellent match for the Cat 385C, 365C and 345D Hydraulic Excavators; and Cat 962H, 966H, 972H, 980H and 988H Wheel Loaders. This results in increased production and lower system costs per unit of volume moved.

735B Articulated Truck Specifications

Gradeability/Speed/Rimpull

To determine performance, read from Gross Weight down to % Total Resistance. Total Resistance equals actual % grade plus 1% for each 10 kg/metric ton (20 lb/ton) of Rolling Resistance. From this point, read horizontally to the curve with the highest attainable speed range. Then, go down to Maximum Speed. Usable Rimpull depends on traction available.

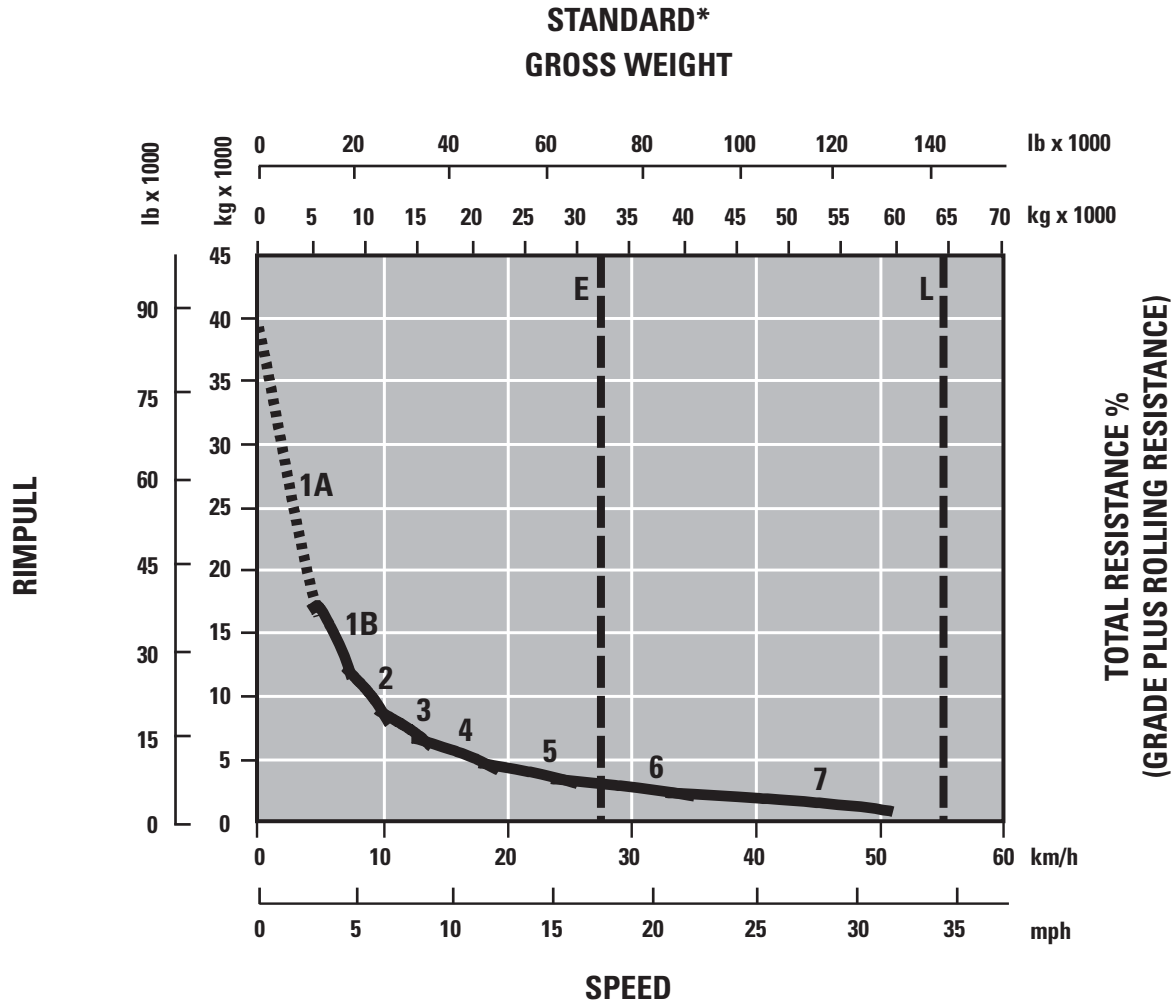

- 1A – 1st Gear (Converter Drive)
- 1B – 1st Gear (Direct Drive)
- 2 – 2nd Gear
- 3 – 3rd Gear
- 4 – 4th Gear
- 5 – 5th Gear
- 6 – 6th Gear
- 7 – 7th Gear

- E – Empty 32 206 kg (71,002 lb)
- L – Loaded 64 906 kg (143,093 lb)
- * at sea level

735B Articulated Truck Specifications

Retarding Performance

To determine performance, read from Gross Weight down to % Effective Grade. Effective Grade equals actual % favorable grade plus 1% for each 10 kg/metric ton (20 lb/ton) of Rolling Resistance. From this point, read horizontally to the curve with the highest attainable speed range. Then, go down to Maximum Speed. Retarding effect on these curves represents full application of the retarder.

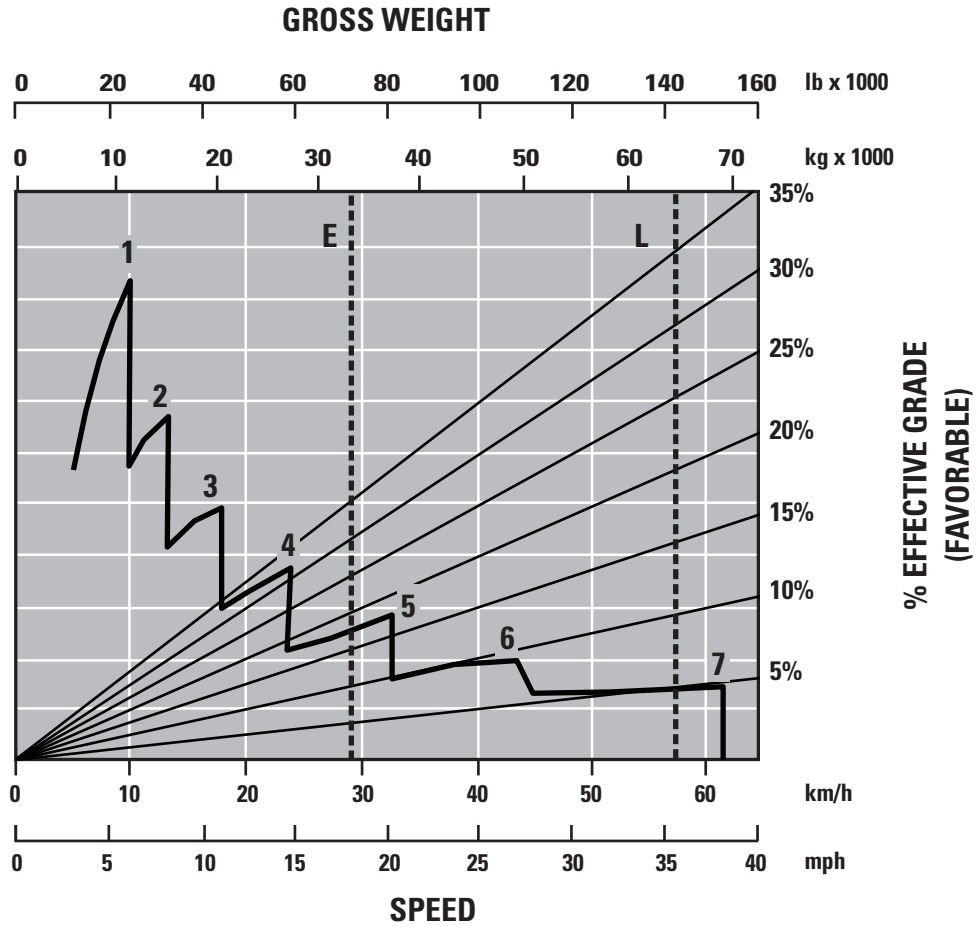

- 1 – 1st Gear
- 2 – 2nd Gear
- 3 – 3rd Gear
- 4 – 4th Gear
- 5 – 5th Gear
- 6 – 6th Gear
- 7 – 7th Gear

- E – Empty 32 206 kg (71,002 lb)
- L – Loaded 64 906 kg (143,093 lb)

Standard Equipment

Standard equipment may vary. Consult your Cat dealer for details.

Air conditioning with R134A refrigerant
Air vents, adjustable
Automatic Traction Control (ATC)
Auto shift seven-speed forward and two-speed reverse transmission
Back up alarm
Body, adapted for exhaust heat
Cat® C15 engine with ACERT™ Technology
Color Multi-Purpose Display (CMPD) incorporating the Cycle Counter and rearview Camera Screen
CD/Radio, heavy duty ready
Differentials, standard with automatic clutched cross-axle and inter-axle differential locks for all axles
Electrical system: 24 volt, 5A 24- to 12-volt converter
Electro hydraulic hoist control
Ether starting aid
Glass windows, laminated and tinted, front
Glass windows, toughened and tinted, sides and rear
Guards: rear window, radiator, crankcase and axle
Headlights, four
Heater and defroster with four-speed fan
Horn, electric
Lights: cab interior, front, side, rear, two reversing/working lights, two stop/tail lights, side width marker, front and rear direction indicators
Mirrors, main and auxiliary, left and right
Mud flaps, wheel arch and body mounted, with transportation tie backs
Oil-cooled brakes, enclosed
Operator and passenger grab hand rails
Product Link
Retarder, engine compression brake

ROPS/FOPS cab, with full instrumentation, including:

- Instrument cluster display module
- Indicator lamps: left turn, secondary steering, primary steering loss, front and center axle brake temp (735B/740B and 740B Ejector only), brake oil pressure, action lamp, transmission fault, park brake, charging system status, differential lock fault, body not in float, right turn, high beam, transmission hold, machine filter warning, retarder, retarder up shift warning
- Gauges: engine oil pressure, engine coolant temperature, torque converter oil temperature, fuel level, fuel tank level gauge
- LCD warnings/indicators: Gear, Alert, Speed, Soot, DPF Regeneration, Engine hours, Primary Steer, 2nd Steer, Machine Security (MSS), Retarder
- Meters: service hour meter, speedometer, tachometer

Seat, fully adjustable, air suspension
Seat, padded passenger
Secondary steering – electronic
S·O·SSM sampling valves
Spill guard, front, integral part of fabricated body
Starting receptacle, electric, remote
Storage – two cup holders, flask receptacle, under seat storage, door pocket, behind seat storage, coat hook
Sun visor
Three-axle, six wheel drive
Tilt and telescopic steering wheel
Tires, 26.5R25, radial
Towing eyes, front and rear tow pin
Two seat belts, retractable
Vandalism protection: lockable caps for fuel tank and hydraulic oil tank
Windows opening side, tinted
Windshield wiper and washer, two speed, intermittent (front)
Windshield wiper and washer, two speed, (rear)

735B Articulated Truck

Optional Equipment

Optional equipment may vary. Consult your Cat dealer for details.

Autolube installation for automatic greasing of bearings
Body liners
Cab roof mounted headlamps
CD/Radio, heavy duty with auxiliary input
Cold Weather Coolant (-51° C/-59.8° F)
Cold weather start attachment
Engine Block Heater
Exhaust heated body
Extensions, fender
Fast fuel fill

Flashing LED Beacon
Fuel Additive – Anti-Waxing
Heated rearview motorized mirrors
Heated seats
Product Link PL 321, PL 522 and PL 523 (where available)
Long wheel base rear chassis (OEM)
Machine Security System (MSS)
Tailgate:
– Scissor-type

Materials and specifications are subject to change without notice.

Featured machines in photos may include additional equipment.

For more complete information on Cat products, dealer services, and industry solutions, visit us on the web at www.cat.com.

© 2011 Caterpillar Inc.
All Rights Reserved.

CAT, CATERPILLAR, ACERT, SAFETY.CAT.COM, their respective logos, “Caterpillar Yellow” and the “Power Edge” trade dress, as well as corporate and product identity used herein, are trademarks of Caterpillar and may not be used without permission.