

777D

Off-Highway Truck



Engine

Engine Model	Cat [®] 3508B EU1	
Gross Power – SAE J1995	746 kW	1,000 hp
Flywheel Power	699 kW	938 hp

Operating Specifications

Nominal Payload Capacity	90.4 tonnes	100 tons
Body Capacity – SAE 2:1	60.1 m ³	78.6 yd ³
• Refer to the Caterpillar [®] 10/10/20 Payload Guidelines.		

Weights – Approximate

Target Gross Machine Operating Weight	163 360 kg	360,143 lb
---------------------------------------	------------	------------

777D Off-Highway Truck

Engineered for performance, designed for comfort, built to last.

Power Train – Engine

The Cat® 3508B EUI engine delivers the power and reliability necessary to perform in the most demanding applications. Designed for efficient operation, the 3508B offers excellent fuel efficiency, lower emissions, reduced engine noise and lower operating costs. **pg. 4**

Power Train – Transmission

The Cat seven-speed power shift transmission, matched with the 3508B electronic unit injection engine, provides consistent power and efficiency over a wide operating speed range for peak power train performance. **pg. 5**

Engine/Power Train Integration

The Cat Data Link electronically combines engine, transmission, brake and operational information to optimize overall truck performance. Stored diagnostic data can be accessed via the Electronic Technician (ET) to improve troubleshooting and reduce downtime. **pg. 6**

Truck Body Systems

Caterpillar designed and built truck bodies ensure optimal performance and reliability in tough hauling applications. Cat dealers can help build an optimum hauling system to maximize truck payloads and extend body and truck wear life. **pg. 14**

Matched Systems

For full truck payloads with minimum loading time, an efficient loading/hauling system starts with a perfect match. Cat dealers can help build an optimum system solution to maximize payloads, minimize loading time and lower operating costs. **pg. 15**

Top Performance.

Developed specifically for mining, quarrying and construction applications, the 777D keeps material moving at high volume to lower your cost-per ton.

Reliable, Durable Operation.

Rugged construction and easy maintenance procedures ensure long life with low operating costs.



Brake System

Cat rear oil-cooled, multiple disc brakes offer exceptional, fade-resistant braking and retarding for maximum performance and productivity in all haul road conditions. Optional Automatic Retarder Control and Traction Control Systems provide optimum braking efficiency. **pg. 8**

Structures

Caterpillar® truck frames are built to resist twisting in the most severe, high impact applications. Mild steel provides flexibility, durability and resistance to impact loads. Castings and forgings in high stress areas provide exceptional strength and durability for long life. **pg. 10**

Operator's Station

The ergonomic cab is designed for operator comfort and ease of operation. Controls and gauges are positioned within easy reach for optimum efficiency and total machine control. An advanced monitoring system keeps the 777D running at peak productivity. **pg. 12**

Serviceability

The 777D is designed for quick and easy servicing. Simplified service and maintenance features reduce downtime, allowing the machine to spend less time being serviced and more time on the haul roads. **pg. 16**

Customer Support

Caterpillar dealers provide unmatched product support, anywhere in the world. With industry-best parts availability and a wide range of maintenance and service options, Cat dealers have what it takes to keep your hauling machines productive. **pg. 17**



Power Train – Engine

The Cat 3508B engine is built for power, reliability and efficiency for superior performance in the toughest applications.

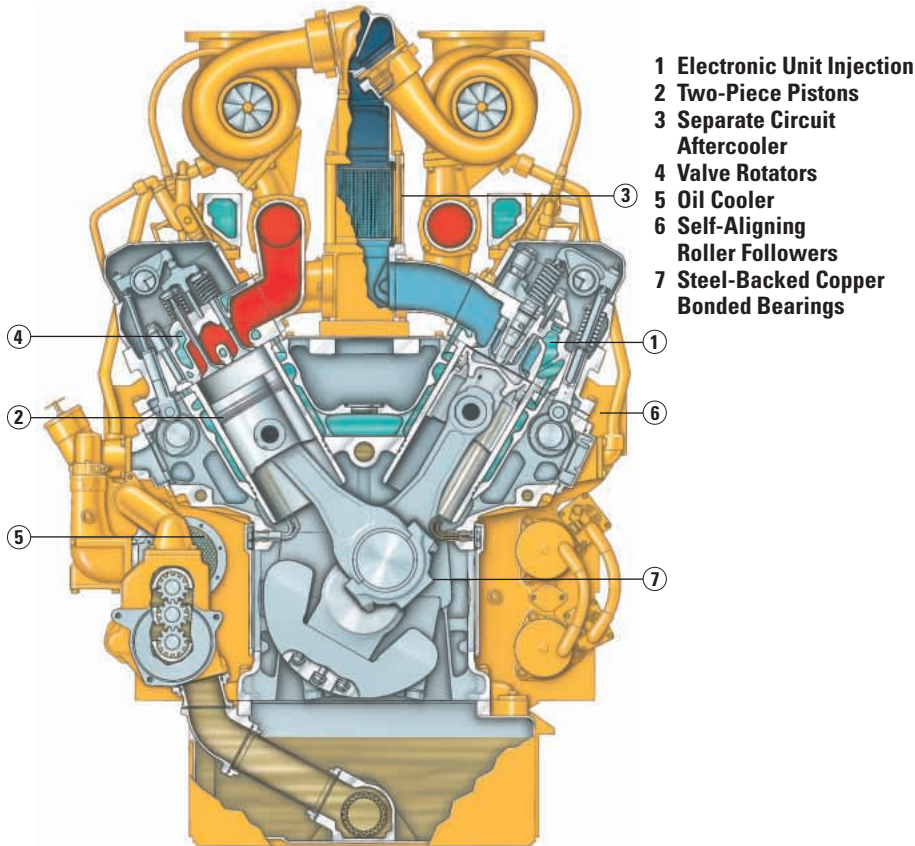

Engine. The Cat 3508B EUI twin turbocharged and aftercooled diesel engine delivers high power and reliability in the world's most demanding applications. The 3508B is an eight-cylinder, four-stroke design that uses long, effective power strokes for more complete fuel combustion and optimum efficiency.

Fuel Efficiency. The 3508B EUI has two percent improved specific fuel consumption over the former 3508 EUI engine.

EPA Compliant. The 3508B engine meets the U.S. Environmental Protection Agency Tier I emissions standards.

Starting System. Features a direct-electric, 24-volt starting system with a 100-amp alternator and four 190-amp-hour, low maintenance, high output, 12-volt batteries for dependable starting.

Altitude Compensation. Designed for maximum operating efficiencies at altitudes under 2228 m (7,500 ft).

High Torque Rise. The 23 percent torque rise provides unequalled lugging force during acceleration, on steep grades and in rough underfoot conditions. Torque rise effectively matches transmission shift points for maximum efficiency and fast cycle times.

Enhanced Life. High displacement, low rpm rating and conservative horsepower ratings mean more time on the haul roads and less time in the shop.

Two-Piece Piston Design. Two-piece articulated pistons with a deep bowl, low volume crevice design enhances combustion efficiency, improves fuel efficiency and lowers emissions.

Electronic Unit Injection (EUI).

The electronically controlled unit injection fuel system senses operating conditions and regulates fuel delivery for optimum fuel efficiency. The proven high-pressure fuel system provides improved response times and more efficient fuel burn with lower emissions and less smoke.

Electronic Control Module (ECM).

ECM utilizes advanced engine management software to monitor, control and protect the engine utilizing self-diagnosing electronic sensors. The computerized system senses operating conditions and power requirements and adjusts engine for peak performance and most efficient operation and at all times.

Separate Circuit Aftercooler. Allows the aftercooler circuit to operate cooler than jacket water temperature for a denser air charge and greater combustion.

Engine Protection. Computerized system electronically protects the engine during cold starts, high altitude operation, air filter plugging, and high exhaust temperature.

Exhaust Diverter (optional). Unique muffler/exhaust design transfers heat to the truck body to keep materials from sticking in cold climates. When in the lowered position, the diverter routes the exhaust through the body; when raised, exhaust is diverted through the muffler.

Power Train – Transmission

Cat power train delivers more power to the ground for greater productivity and lower operating costs.

1) Transmission. The Cat seven-speed planetary power shift transmission is matched with the direct-injection 3508B diesel engine to deliver constant power over a wide range of operating speeds.

Robust Design. Designed for the higher horsepower of the 3508B engine, the proven planetary power shift transmission is built tough for long life between overhauls.

Long Life. A dedicated oil tank and circuit provides cooler, cleaner oil for maximum performance and longer component life.

Transmission Chassis Control (TCC). TCC uses electronically transferred engine rpm data to execute shifts at preset points for optimum performance, efficiency and clutch life.

2) Lock-Up Torque Converter. Combines maximum rimpull and the cushioned shifting of torque converter drive with the efficiency and performance of direct drive. Engages at approximately 6.4 km/h (4 mph), delivering more power to the wheels.

Lock-Up Clutch. Quickly releases and re-engages to reduce power train torque loads for smoother shifting, long life and a more comfortable ride.

Smooth Shifting. Individual clutch modulation provides smooth clutch engagements to optimize performance and extend clutch life.

3) Final Drives. Cat final drives work as a system with the planetary power shift transmission to deliver maximum power to the ground. Built to withstand the forces of high torque and impact loads, double reduction final drives provide high torque multiplication (19.16:1) to further reduce drive train stress.



Axles. Full floating axles are shot peened to relieve internal stresses and increase durability. Rolled splines also provide increased service life.

Wheels and Rims. Cast rear wheels and Cat center-mount rims are mounted using studs and nuts to minimize maintenance and maximize durability.

Steering System. Hydraulic steering control system is designed for exceptional smoothness and precise control. A separate circuit prevents cross contamination for long life.

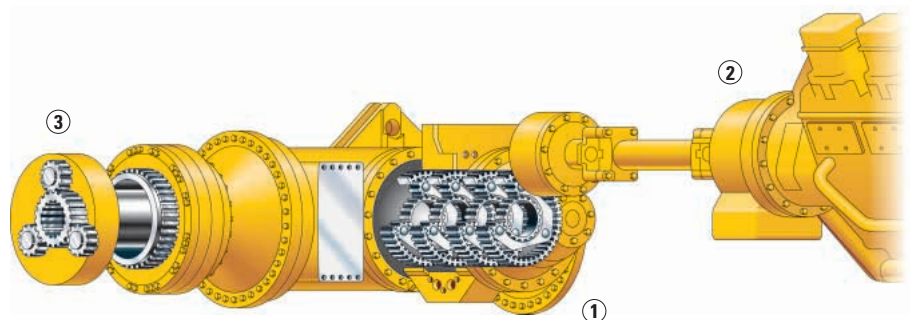

Engine/Power Train Integration

Electronically combines critical power train components to work more intelligently to optimize overall truck performance.

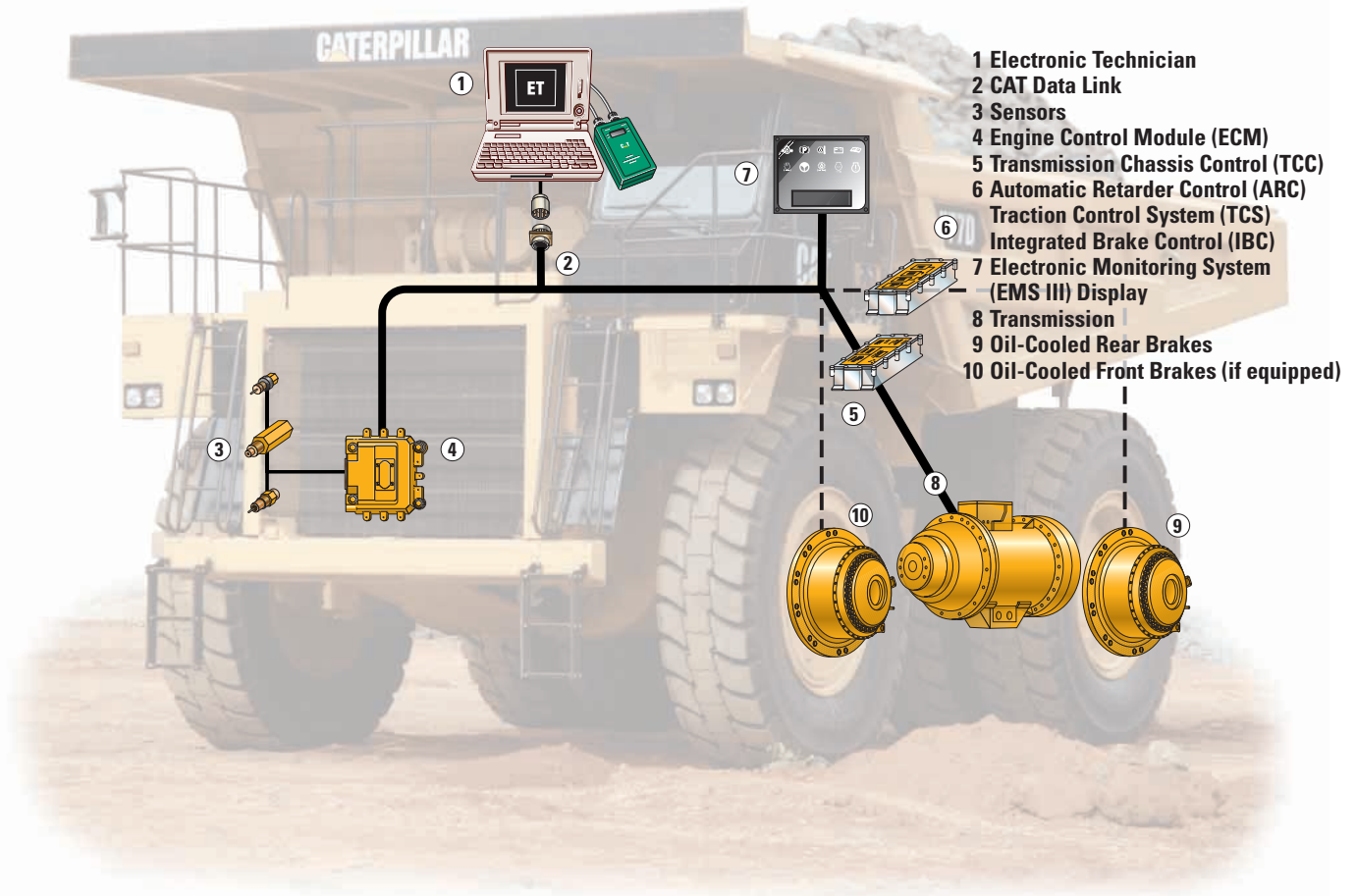

Cat Data Link. Electronically integrates machine computer systems to optimize overall power train performance, increase reliability and component life and reduce operating costs.

Economy Mode. Using the Electronic Technician (Cat ET) service tool, the mechanic can reduce the engine setting to 920 gross horsepower to match loader/crusher availability and conserve fuel.

Transmission Chassis Control (TCC). TCC uses electronically transferred engine rpm data to execute shifts at preset points for optimum performance efficiency and clutch life.

The transmission chassis controller provides integrated functionality, to the following electronic controls:

- **Controlled Throttle Shifting.** Regulates engine rpm during shifting to reduce power train stress and clutch wear by controlling engine speed, torque converter lock-up and transmission clutch engagement for smoother shifts and longer component life.
- **Directional Shift Management.** Regulates engine speed during directional shifts to prevent damage caused by high speed directional changes.

- **Neutral Coast Inhibitor.** Prevents transmission from shifting to neutral at speeds above 6.5 km/h (4 mph) to protect the transmission from operating with insufficient lubrication.

- **Body-up Shift Limiter.** Prevents the transmission from shifting above a pre-programmed gear without the body fully lowered.

- **Body-up Reverse Neutralizer.** Automatically shifts the transmission to neutral if the hoist lever is activated while transmission is shifted in reverse.

- **Overspeed Protection.** The transmission control electronically senses engine conditions and automatically up-shifts one gear to prevent overspeeding. If overspeeding occurs in top gear, the lock-up clutch is disengaged.

- **Programmable Top Gear.**

Transmission top gear maximum can be set using the Cat ET service tool to help the operator maintain speed limits.

- **Downshift Inhibitor.** Prevents engine overspeeding by keeping the transmission from downshifting until engine speed reaches the downshift point.

- **Economy Shift Mode.** Modifies engine maps, resulting in greater fuel economy.

- **Reverse Shift Inhibitor.** Protects the engine from abrupt directional changes by slowing down the engine before shifting the transmission into reverse.



Electronic Technician (ET). Cat ET service tool provides service technicians with easy access to stored diagnostic data through the Cat Data Link to simplify problem diagnosis and increase machine availability.

- Cat ET displays the status of all engine parameters, including throttle position, timing and fuel flow.
- Cat ET replaces 13 mechanical tools to perform functions like cylinder cutout checks, injector solenoid tests and timing calibration.

Diagnostic Capability. Critical data from the electronic engine and transmission controls, including transmission shifting, engine speed and fuel consumption, provides service technicians with enhanced diagnostic capability to reduce downtime and operating costs.

Electronic Monitoring System (EMS III).

EMS III allows the operator to view requested information and utilizes a three-category warning system to alert the operator of abnormal machine conditions. Data can be downloaded via the Electronic Technician (ET) service tool for quick diagnosis and repair.

Optional Attachments. Caterpillar offers optional braking controls that are electronically integrated with the Cat Data Link to enhance retarding, traction and braking performance:

- **Automatic Retarder Control (ARC).**

Optional ARC electronically controls retarding on grade to maintain optimum engine rpm and oil cooling.

- **Traction Control System (TCS).**

Optional TCS electronically monitors and controls rear wheel slippage for greater traction in poor underfoot conditions.

- **Integrated Braking Control (IBC).**

Optional IBC integrates Automatic Retarder Control and Traction Control into one system for optimum performance and efficiency.

Brake System

Reliable braking with superior control gives the operator the confidence to focus on productivity.



Integrated Braking System. The Cat oil-cooled braking system delivers reliable performance and control in the most extreme haul road conditions. The integrated system combines the service, secondary, parking brake and retarding functions in the same robust system for optimum braking efficiency.

Rear Oil-Cooled Multiple Disc Brakes. Caterpillar rear-wheel, forced oil-cooled, multiple disc service brakes are continuously cooled by water-to-oil heat exchangers for exceptional, non-fade braking and retarding performance.

Brake Design. Cat oil-cooled disc brakes are designed with large discs and plates for reliable, adjustment-free operation and performance. Brakes are completely enclosed and sealed to prevent contamination and reduce maintenance.

Long Life. An oil film prevents direct contact between the discs. This design absorbs the braking forces by shearing the oil molecules and carrying heat away to extend brake life.

Dry Front Caliper Disc Brakes. Disc brakes fitted on front wheels as standard fitment.

Pistons. The Caterpillar two-piston design combines the service, secondary, parking brake and retarding functions in the same system. The primary piston hydraulically actuates both service and retarding functions. The secondary piston is spring-applied and held in the disengaged position by hydraulic pressure. If hydraulic system pressure drops below a specified level, the spring-applied secondary piston automatically applies the brakes.

Parking Brake. Oil-cooled, spring-applied, hydraulically released parking brake is applied to rear wheels for superior parking capability on all grades up to 15 percent.

Automatic Retarder Control (ARC) (optional). ARC electronically controls braking on grade to maintain engine at approximately 1,900 rpm (adjustable from 1,850-1,950 rpm in increments of 10). ARC is deactivated when the operator applies the brakes or throttle.

ARC Benefits.

- **Engine Overspeed Protection.** Automatically activates ARC when engine speed exceeds factory preset levels, regardless of operator inputs, to avoid potentially damaging engine overspeeds.
- **Ease of Operation.** ARC increases operating ease, resulting in greater operator confidence with less fatigue.

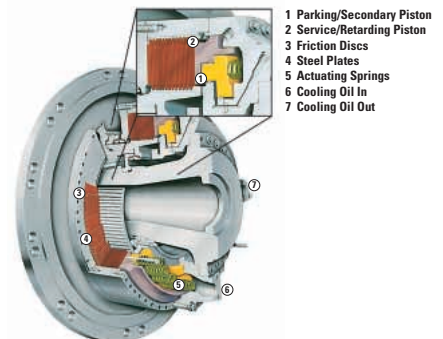

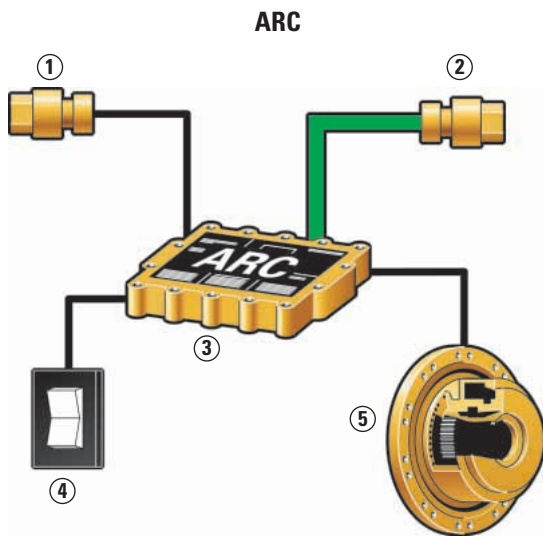

- 1 Service Brake Sensor
- 2 Engine Sensor
- 3 ARC
- 4 ARC Switch
- 5 Brakes

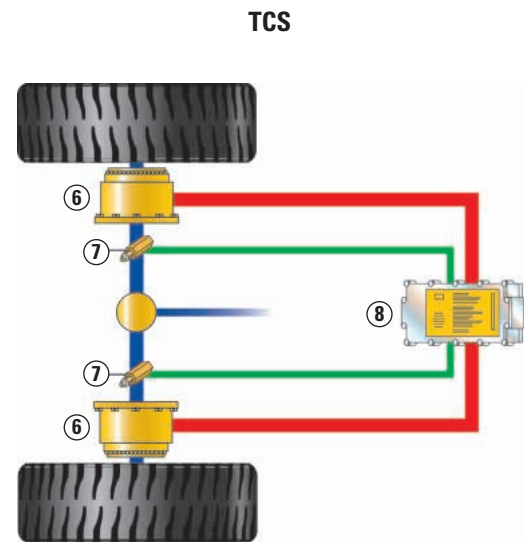

TCS

- **Faster Speeds.** ARC allows the operator to maintain optimum engine speeds for faster downhill hauls and greater productivity.

- **Superior Control.** Automatic brake modulation offers a smoother ride and better control in slippery conditions, allowing the operator to concentrate on driving.

- **Fuel Efficiency.** During retarding applications the engine ECM does not inject fuel into the cylinders for additional fuel economy.

Four Corner Retarding. If equipped with front oil cooled disc brake, four corner retarding with 60/40 percent split (rear/front) in braking effort provides superior control in slippery conditions. Balanced front to rear brake torque provides exceptional braking performance and minimizes wheel lock-up, especially during retarding.

ARC Operating Efficiency Advantages

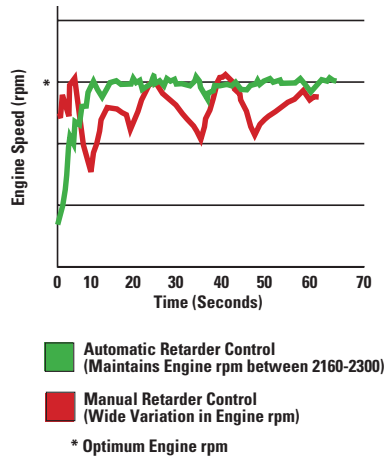

Traction Control System (TCS) (optional).

TCS electronically monitors and controls rear wheel slippage for greater traction and enhanced truck performance in poor underfoot conditions. If slippage exceeds a set limit, the oil-cooled disc brakes engage to slow the spinning wheel. Torque is then automatically transferred to the wheel with better traction.

- **Differential Action.** Normal differential action provides superior maneuvering and control in slippery conditions.

- **System Back-Up.** Should sensors fail, normal differential action is still available to maintain steering and control.

Integrated Braking Control (IBC) (optional). IBC combines Automatic Retarder Control (ARC) and Traction Control System (TCS) into one integrated brake control system for optimum efficiency, performance and reliability.

Cat Data Link. All control modules communicate via the Cat Data Link and work together as an integrated system to maximize production efficiency and extend component life.

Structures

Rugged Cat structures are the backbone of the 777D off-highway truck's durability.

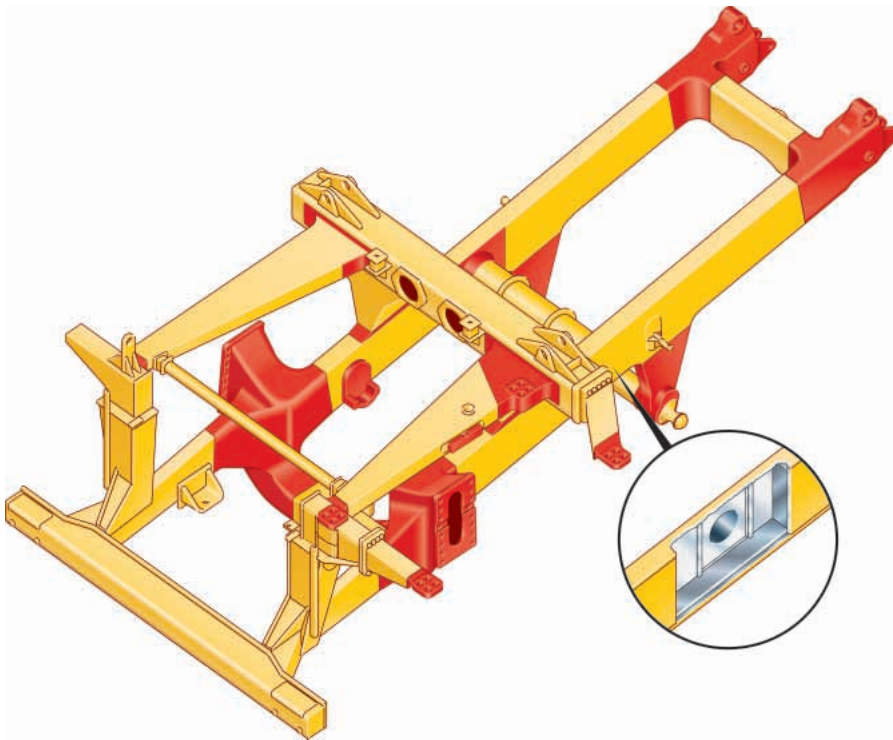

Box-Section Design. The 777D frame uses a box-section design, incorporating two forgings and 22 castings in high stress areas with deep penetrating and continuous wrap-around welds to resist damage from twisting loads without adding extra weight.

Steel Structures. Mild steel used throughout frame provides flexibility, durability and resistance to impact loads, even in cold climates, and allows for easy field repairs.

Castings. Castings have large radii with internal reinforcing ribs to dissipate stress in areas of high stress concentration. Castings move welds to lower stress areas for greater frame life.

Serviceability. The open box-section frame design allows easy access to power train components, reducing overall removal and installation time, and lowering overall repair costs. The raised and pinned body allows excellent access to the transmission.

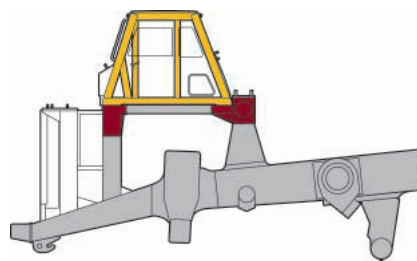

Integral Four-Post ROPS Cab.

Resiliently mounted to the main frame to reduce vibration and sound, the integral ROPS structure is designed as an extension of the truck frame. The ROPS/FOPS structure provides “five-sided protection” for the operator.

Steering and Suspension System.

Cat integrated steering and suspension system is designed for precise steering, excellent maneuverability with minimal tire wear and superior ride control to optimize operator comfort all shift long.

Steering System. A twin double-acting cylinder steering system is designed to deliver precise control under all loading and underfoot conditions. The steering system is separate from the main hydraulic system to prevent cross-contamination and overheating from other sources.

Supplemental Steering. Main hydraulic steering system is backed by a battery powered supplemental steering system which uses pressure accumulators and allows up to three 90 degree turns in case of engine failure. System automatically engages when needed.

Front Spindles and Wheels. Rigidly mounted to the cylinder rods for reliable operation and long life.

Maximum Tire Life. The steering system is designed to maintain zero toe-in/toe-out when tie-rods and front suspension cylinders are properly adjusted to minimize tire scuffing and maximize tire life.

Suspension System. Designed to dissipate haul road and loading impacts for longer frame life and a more comfortable ride.

Cylinders. Four independent self-contained, nitrogen/oil pneumatic, variable-rebound/suspension cylinders are designed to absorb shocks in the most severe applications.

Durable Design. Rugged cylinders utilize large diameter bore and low pressure nitrogen/oil design for long life with minimal maintenance.

- **Front.** Front cylinders with preset caster and camber are mounted to the frame and serve as steering kingpins for a tight turning radius with excellent maneuverability and low maintenance.

- **Rear.** Rear cylinders allow axle oscillation and absorb bending and twisting stresses caused by uneven and rough haul roads rather than transmitting them to the main frame.

Ride Control. Built-in rebound control and strategically located cab relative to the front axle minimizes the effect of pitch and bounce, resulting in a more comfortable ride, higher productivity and less fatigue.

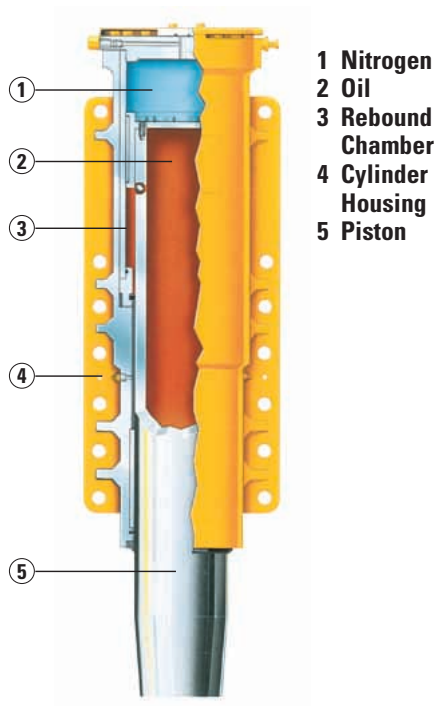

Operator's Station

Ergonomically designed for operator comfort, superior control and high productivity.



Ergonomic Layout. The 777D operator station is ergonomically designed for total machine control in a comfortable and productive environment. All controls, levers switches and gauges are positioned to maximize productivity and minimize operator fatigue.

1) Dash. Wrap-around dash puts all controls within each reach of the operator. Backlit displays enhance visibility.

2) Air Suspension Seat. Ergonomically designed, fully adjustable Cat Comfort Air Suspension Seat with adjustable armrests provides optimal driving comfort. A wide, retractable seat belt provides a secure, comfortable restraint.

3) Steering Column. Sport wheel with tilt and telescopic steering provides a comfortable driving position and greater control.

4) Transmission Console. Ergonomic gear shift lever with backlit gear indicators optimize efficiency.

5) Viewing Area. Designed for excellent all-around visibility and clear sight lines to the haul road, the large viewing area enables the operator to maneuver with confidence for greater productivity.

6) ROPS/FOPS Cab. Integral, sound-suppressed cab is resiliently mounted to the mainframe to isolate the operator from sound and vibration for a quiet, secure and comfortable ride.

7) Operator Controls. Easy to reach turn signal, high beam, windshield wiper/washer, and retarder controls are designed for optimum efficiency and comfort.

8) Storage Compartment. Large compartment located under the trainer seat provides an uncluttered working environment.

9) Trainer Seat. Full-size, fully padded trainer seat features a backrest, wide hip and shoulder room, and seat belt for secure travel.

10) Monitoring System. Electronic Monitoring System (EMS III) features easy-to-read displays for precise machine status information. Data can be downloaded via the Electronic Technician (Cat ET) service tool for quick diagnosis and repair.

- Gauge Cluster maintains a constant display of vital machine functions, including: coolant temperature, oil temperature, brake air pressure, and fuel level.
- Speedometer/Tachometer Module monitors three systems: engine speed, ground speed and actual gear.
- Message Center displays messages requested by operator and advises operator of abnormal machine conditions.

11) Heating/Air Conditioning. Electronically controlled four-speed fan and nine vents deliver temperature-controlled air circulation for a comfortable working environment in any climate. (optional)

12) Foot Pedals. Ergonomically designed for comfort. Secondary brake pedal is conveniently located on the floor for easy operator control.

13) Operator Window. Powered operator window offers simple operation and an unobstructed view.



14) Hoist Levers. Four-position electronic hoist system with fingertip control provides low impact body-down snubbing. Mounted next to the operator's seat for ease of operation.

15) Truck Production Management System (TPMS) (optional). TPMS provides valuable payload and cycle time data to improve productivity.

- Utilizes strut pressure sensors and on-board microprocessor to determine payload weight.
- Delivers consistent, accurate payloads and improves efficiency by minimizing overloading and underloading.
- External lights signal loading tool operator when payload is reached.
- On-board computer stores up to 1,400 cycles for analysis of payload weight, cycle times, distances, and actual cycle dates and times.
- System is accurate within $\pm 5\%$ under normal loading conditions over a normal shift.



Radio Ready. Cab is prewired with power converter, speakers, wiring harness, antenna and provision for add-on communication systems.

Product Link Ready. Optional Product Link system provides a two-way communication flow of vital machine data and location information between the dealer and the customer. Product Link provides updates on service meter hours, machine condition, machine location as well as integrated mapping/route planning.

Payload Weight Distribution

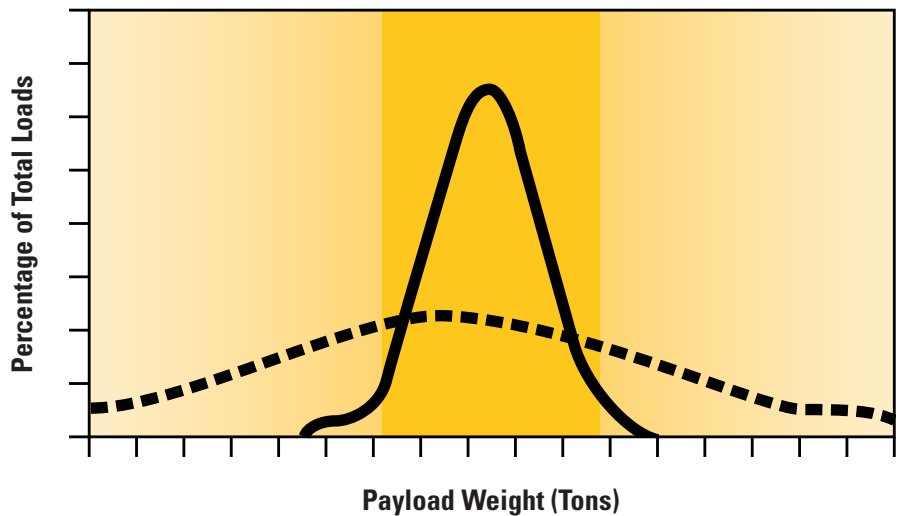

- | | |
|--|--|
| Recommended Payload Range | With Production Management |
| Inefficient Payload Ranges | Without Production Management |

Truck Body Systems

Cat designed and built for rugged performance and reliability in the toughest hauling applications.



Body/Chassis Integration. Caterpillar truck bodies are designed and matched with the integrated chassis system for optimum structural reliability, durability and long life.

Electronic Hoist Control. Provides the operator with better control of the load when dumping, including over-center load control and modulated control throughout the operating range. The automatic body snubbing feature reduces impact on the frame, hoist cylinders and operator.

Fast Hoist Cycle Times. Two-stage hoist cylinders provide fast dump cycle times of 15 seconds for raise and 13 seconds for lower.

Body Design. Cat truck bodies are designed for optimal strength, capacity and durability. Wear surfaces are equipped to handle even the toughest impact and abrasion over the long haul without diminishing capacity.

- Five-Sided Beams join the sidewall and floor junctions for increased body rigidity and strength.
- Wide Ribs in body floor provide increased durability and impact support.
- Full-Length Stringers create strength and rigidity throughout the bed.
- Box Section Beams offer increased durability in the floor, sidewall, top rail, corner, and cab canopy areas.

- Wide Body Design provides complete coverage of tires, eliminating the need for rock deflectors.



Dual-Slope Body. The advanced dual-slope body design with V-shaped floor increases load retention, maintains a low center of gravity, reduces shock loading, and maintains optimum load distribution on steep inclines and in challenging haul road conditions.

- Reinforced, rolled steel top rail increases body strength and protects the body from damage caused by the loading tool or falling material
- 8 degree “V” reduces shock loading and centers the load.
- 10 degree forward body slope and 18 degree ducktail slope helps retain loads on steep grades.
- Maintains a load height of 4380 mm (14 ft 3 in) for faster, more confident loading.
- 60.1 m³ (78.6 yd³) capacity allows operators to achieve rated payload in 2,900 lb/BCY material.

Body Liners. Liner options are available to save weight and help extend the body system’s life. Wear surfaces and liners are equipped to handle tough impact loads while resisting abrasion. Wear plates deliver long life in high wear areas.

Matched Systems

An efficient loading/hauling system starts with a perfect match.

Efficient Combination. The 777D is designed to deliver full payloads and fast cycle times. When properly matched, Cat trucks and loading tools create an efficient combination to maximize volume of material moved at the lowest operating cost.

Machine Configuration Options. Choose from various truck configuration options to match specific site and hauling conditions.

Tire Options. Choose from a range of tire options to match specific underfoot conditions, haul road conditions and hauling distances to maximize performance and extend tire life.

Systems Approach. The Caterpillar systems approach means increased efficiencies through common design. Cat haul trucks, loaders and excavators use common engines, parts and operator environments which add up to more uptime, greater productivity and lower maintenance costs.

Loader Match. Designed to work as an optimum pass/match system, the 777D is best sized to match the following Caterpillar loading tools:

Wheel Loaders

- 990 II – 6 pass/match
- 992G – 4 pass/match



Serviceability

Less time spent on maintenance means more more time on the haul roads.



Servicing Ease. Easy access to daily service points simplifies servicing and reduces time spent on regular maintenance procedures. Enhanced serviceability and extended service intervals are designed to increase machine availability and productivity.

Maintenance Platform. Provides access to engine, air filters, steering hydraulic tank and battery compartment.

In-Frame Access. Permits easy access to major components for easy servicing and removal.

Ground-Level Access. Allows convenient servicing to tanks, filters, drains, battery disconnect and engine shutdown.

Fast Fill Service Center (optional). Wiggins fast fill service center features high speed fuel and oil exchange.

Scheduled Oil Sampling. S•O•SSM sampling valves speed sampling and analysis reliability.

Pressure Test Points. Disconnect valves are conveniently located throughout the hydraulic systems for easy pressure testing.

Air Filters. Radial seal air filters are easy to change, reducing time required for air filter maintenance.

Sealed Electrical Connectors. Electrical connectors are sealed to lock out dust and moisture. Harnesses are braided for protection. Wires are color coded for easy diagnosis and repair.

Spin-on Filters. Spin-on filters for fuel and oil systems reduce changing time and help assure clean, tight seals.

On-Board Diagnostic Systems. EMS III continuously checks all critical machine functions and components, and helps locate faults quickly for faster repair. Electronic control system enables quick diagnosis of engine conditions and effective maintenance and repairs utilizing the Electronic Technician (ET) service tool.

Customer Support

Caterpillar dealers have what it takes to keep haul trucks productive.

Machine Selection. Make detailed comparisons of the machines under consideration before purchase. Cat dealers can estimate component life, preventive maintenance cost, and the true cost of lost production.

Purchase. Look past initial price. Consider the financing options available, as well as day-to-day operating costs. This is also the time to look at dealer services that can be included in the cost of the machine to lower equipment owning and operating costs over the long run.

Financing. Your dealer is an expert at arranging affordable financing options for all Caterpillar products.

Product Support. You will find nearly all parts at your dealer parts counter. Cat dealers use a worldwide computer network to locate in-stock parts to minimize machine downtime. Save money with Cat Reman parts. Receive the same warranty and reliability as new products at a savings of 40% to 70%.

Literature Support. Operation and maintenance manuals are easy to use, helping you get the full value of your equipment investment.

Customer Support Agreements. Cat dealers offer a variety of product support agreements, and work with customers to develop a plan that meets specific needs. Plans can cover the entire machine, including attachments, to help protect your investments.



Operation. Improving operating techniques can boost your profits. Your Cat dealer has training videotapes, literature and other ideas to help you increase productivity.

Replacement. Repair, rebuild or replace? Your Cat dealer can help you evaluate the cost involved so you can make the right choice.

www.cat.com. For more complete information on Cat products, dealer services, and industry solutions, visit us on the web at www.cat.com.

Engine

Engine Model	Cat® 3508B EUI	
Gross Power – SAE J1995	746 kW	1,000 hp
Net Power – SAE J1349	699 kW	938 hp
Net Power – Cat	699 kW	938 hp
Flywheel Power	699 kW	938 hp
Net Power – ISO 9249	699 kW	938 hp
Net Power – 80/1269/EEC	699 kW	938 hp
Peak Torque	4713 N·m	3,476 lb ft
Torque Rise	23%	
Bore	170 mm	6.7 in
Stroke	190 mm	7.5 in
Displacement	34.5 L	2,105 in ³

- Net power advertised is the power available at rated speed of 1750 rpm, measured at the flywheel when the engine is equipped with fan, air cleaner, muffler and alternator.
- Ratings based on standard air conditions of 25° C (77° F) and 99 kPa (29.32 Hg) dry barometer. Power based on fuel having API gravity of 35 at 16° C (60° F) and an LHV of 42 780 kJ/kg (18,390 BTU/lb) when engine used at 30° C (86° F).
- No engine derating required up to 2288 m (7,500 ft) altitude.
- Meets U.S. Environmental Protection Agency Tier 1 emissions standards.

Weights – Approximate

Target Gross Machine	163 360 kg	360,143 lb
Operating Weight		
Operating Weight – empty	64 670 kg	142,573 lb

Operating Specifications

Nominal Payload Capacity	90.4 tonnes	100 tons
Body Capacity – Struck	42.1 m ³	55.06 yd ³
Body Capacity – SAE 2:1	60.1 m ³	78.6 yd ³

- Refer to the Caterpillar 10/10/20 Payload Guidelines.

Transmission

Forward 1	10.5 km/h	6.5 mph
Forward 2	14.3 km/h	8.9 mph
Forward 3	19.3 km/h	12 mph
Forward 4	26 km/h	16.2 mph
Forward 5	34.9 km/h	21.9 mph
Forward 6	46.6 km/h	29.4 mph
Forward 7	60.4 km/h	39.9 mph
Reverse	11.9 km/h	7.4 mph

- Maximum travel speeds with standard 27.00-R49 tires.

Final Drives

Differential Ratio	2.74:1	
Planetary Ratio	7.00:1	
Total Reduction Ratio	19.16:1	

- Planetary, full-floating.

Brakes

Brake Surface – Front	2787 cm ²	432 in ²
Brake Surface – Rear	102 116 cm ²	15,828 in ²

- Meets ISO 3450:1996 standards up to 163 293 kg (360,000 lb) gross operating weight.

Body Hoists

Pump Flow – High Idle	498 L/min	131.5 gal/min
Relief Valve Setting – Raise	18 962 kPa	2,750 psi
Relief Valve Setting – Lower	18 950 kPa	3,450 psi
Body Raise Time – High Idle	15 Seconds	
Body Lower Time – Float	13 Seconds	
Body Power Down – High Idle	13 Seconds	

Capacity – Dual Slope – 100% fill factor

Struck	42.1 m ³	55 yd ³
Heaped 2:1 (SAE)	60.1 m ³	78.6 yd ³

Weight Distributions – Approximate

Front Axle – Empty	47%	
Front Axle – Loaded	33%	
Rear Axle – Empty	53%	
Rear Axle – Loaded	67%	

Suspension

Effective Cylinder Stroke – Front	318 mm	12.5 in
Effective Cylinder Stroke – Rear	165 mm	6.5 in
Rear Axle Oscillation	5.4°	

Approximate Weights – Dual Slope

Empty vehicle	64 670 kg	142,573 lb
Chassis	46 600 kg	107,144 lb
Body	16 070 kg	35,428 lb

Service Refill Capacities

Fuel Tank	1137 L	300 gal
Cooling System	268 L	71 gal
Crankcase	91 L	24 gal
Differentials and Final Drives	306 L	81 gal
Steering Tank	40 L	11 gal
Torque Converter/Brake/ Hoist Hydraulic Tank	250 L	66 gal
Torque Converter/ Transmission Tank	95 L	25 gal

Tires

Standard Tire 27.00-R49 (E4) Tire

- Productive capabilities of the 777D truck are such that, under certain job conditions, TKPH (TMPH) capabilities of standard or optional tires could be exceeded and, therefore, limit production.
- Caterpillar recommends the customer evaluate all job conditions and consult the tire manufacturer for proper tire selection.

ROPS

ROPS/FOPS Standards SAE J1040 MAY94,
ISO 3471:1997

- ROPS (Rollover Protective Structure) for cab offered by Caterpillar meets SAE J1040 MAY94 and ISO 3471:1997 Level II ROPS criteria.

Sound

Sound Standards ANSI/SAE J1166 MAY90,
SAE J88 JUN96

- The operator sound exposure Leq (equivalent sound pressure level) measured according to work cycle procedures specified in ANSI/SAE J1166 MAY90 is 78 dB(A) for cab offered by Caterpillar, when properly installed and maintained and tested with doors and windows closed.
- The exterior sound pressure level for the standard machine measured at a distance of 15 m (49 ft) according to the test procedures specified in SAE J88 JUN86, mid-gear moving operation is 90 dB(A).
- Hearing protection may be needed when operating with an open operator station and cab (when not properly maintained or doors/windows open) for extended periods or in a noisy environment.

Steering

Steering Standards SAE J1511 OCT90,
ISO 5010:1992 (E)

- Turning diameter on front wheel track with standard tires: 25.3 m (83 ft).
- Machine clearance turning circle: 28.4 m (93 ft 2 in).
- Steering angle, left or right: 30.5 degrees.
- Separate hydraulic system prevents cross contamination.

Dimensions

All dimensions are approximate. (Shown with dual slope body)

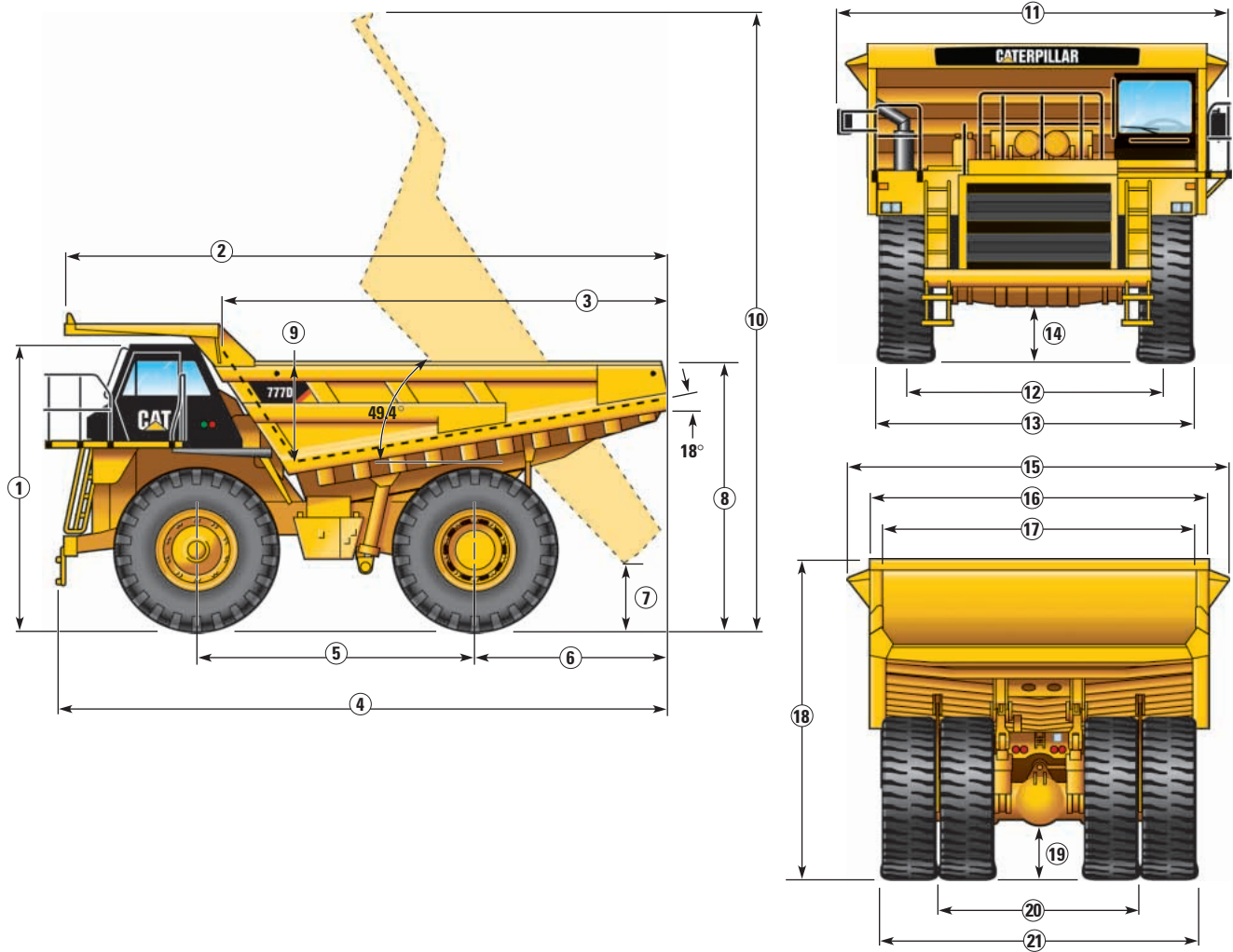

Dual Slope		
1	Height to Top of ROPS – Full	4472 mm 14 ft 8 in
1	Height to Top of ROPS – Empty	4567 mm 15 ft
2	Overall Body Length	9525 mm 31 ft 3 in
3	Inside Body Length	7234 mm 23 ft 9 in
4	Overall Length	9780 mm 32 ft 1 in
5	Wheelbase	4570 mm 15 ft
6	Rear Axle to Tail	3020 mm 9 ft 11 in
7	Dump Clearance – Empty	1164 mm 3 ft 10 in
7	Dump Clearance – Loaded	1062 mm 3 ft 6 in
8	Loading Height – Empty	4380 mm 14 ft 4 in
9	Inside Body Depth – Max	1898 mm 6 ft 3 in
10	Overall Height – Body Raised	10 059 mm 33 ft

Dual Slope		
11	Operating Width	6105 mm 20 ft
12	Centerline Front Tire Width	4173 mm 13 ft 8 in
13	Overall Front Tire Width	4961 mm 16 ft 3 in
14	Engine Guard Clearance – Empty	700 mm 2 ft 4 in
15	Overall Canopy Width	6048 mm 19 ft 10 in
16	Outside Body Width	5524 mm 18 ft 2 in
17	Inside Body Width	5200 mm 17 ft 1 in
18	Front Canopy Height – Empty	5147 mm 16 ft 10 in
18	Front Canopy Height – Loaded	5045 mm 16 ft 6 in
19	Rear Axle Clearance – Empty	750 mm 2 ft 6 in
20	Centerline Rear Dual Tire Width	3576 mm 11 ft 9 in
21	Overall Rear Dual Tire Width	5262 mm 17 ft 3 in

Gradeability/Speed/Rimpull

To determine gradeability performance: Read from gross weight down to the percent of total resistance. Total resistance equals actual percent grade plus 1% for each 10 kg/t (20 lb/ton) of rolling resistance. From this weight-resistance point, read

horizontally to the curve with the highest obtainable gear, then down to maximum speed. Usable rimpull will depend upon traction available and weight on drive wheels.

- Typical Field Empty Weight
- 163 360 kg (360,143 lb) Load

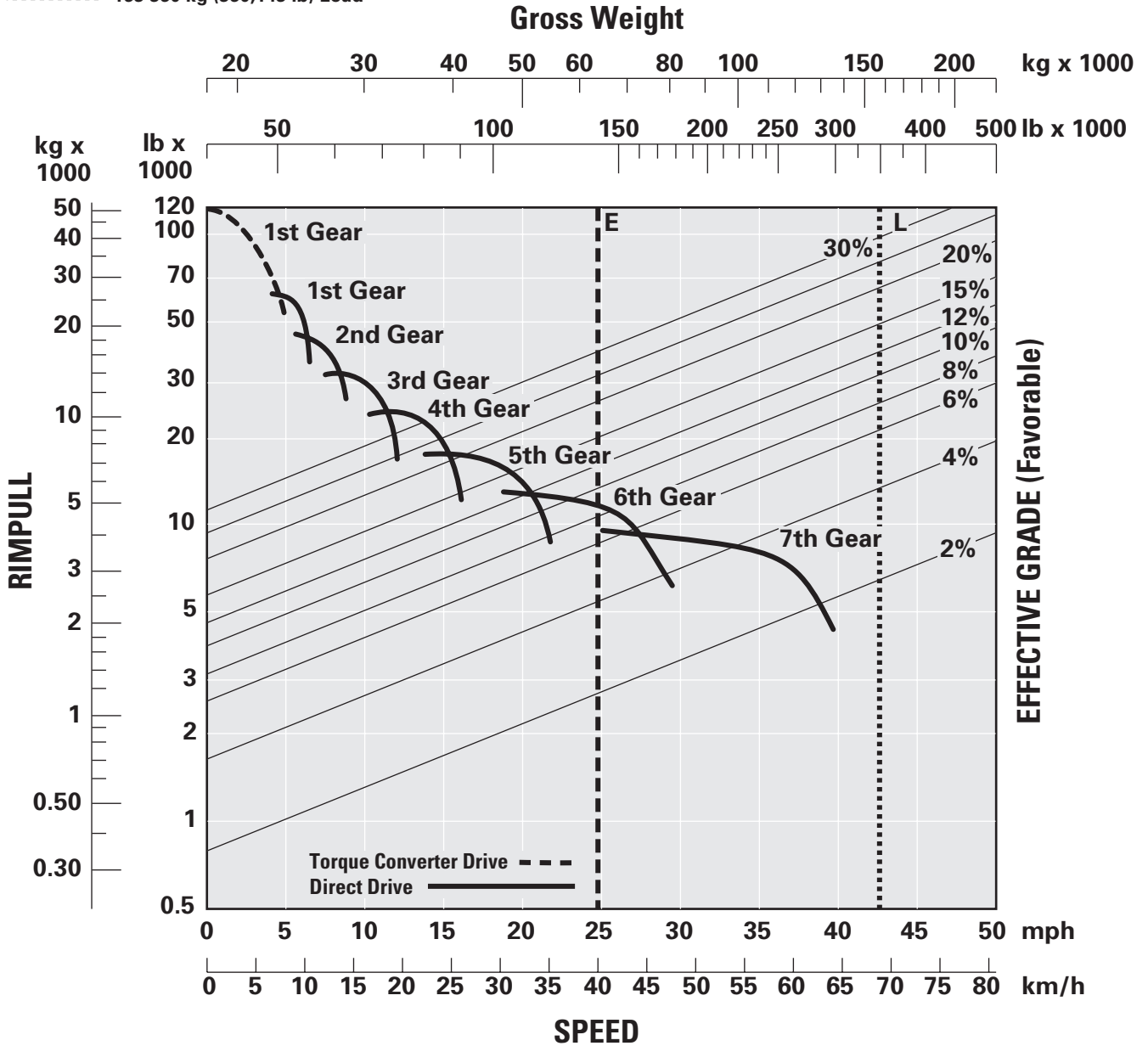

Retarding Performance

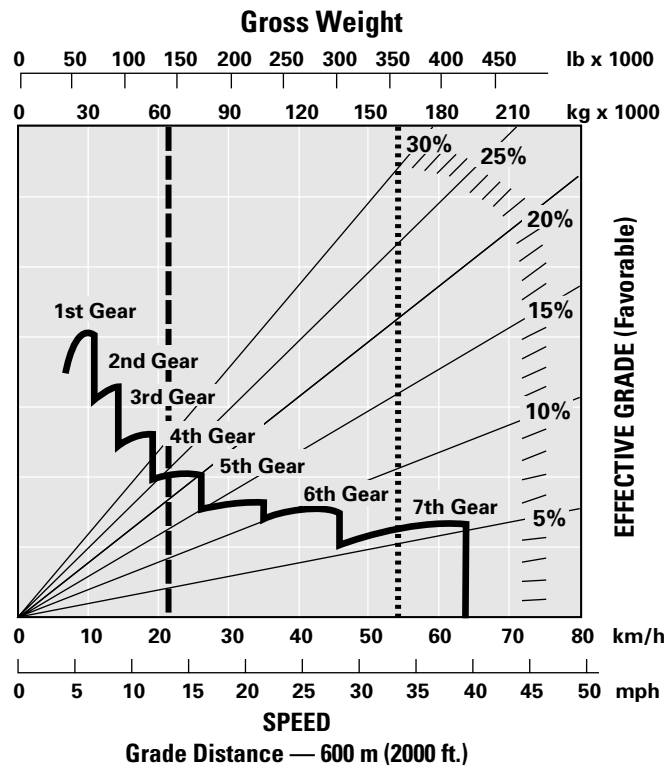
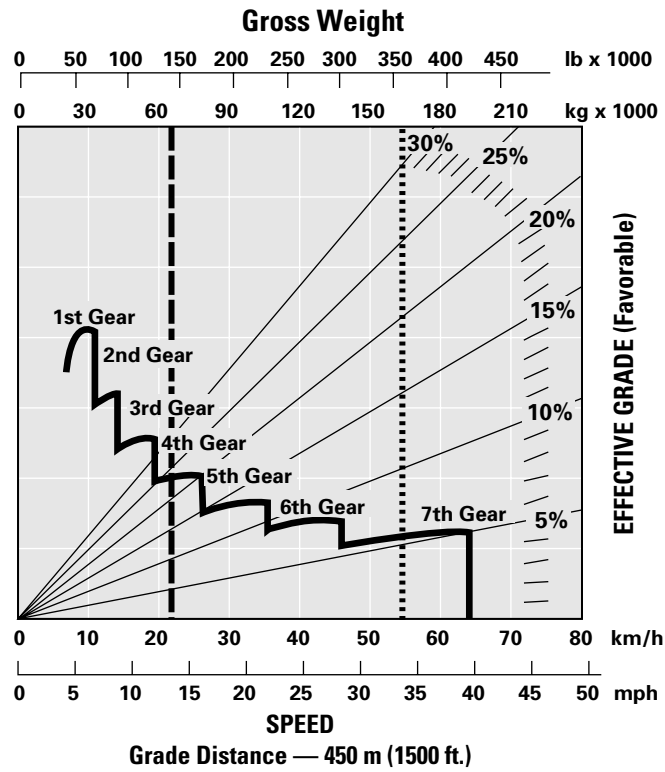

Retarding Performance

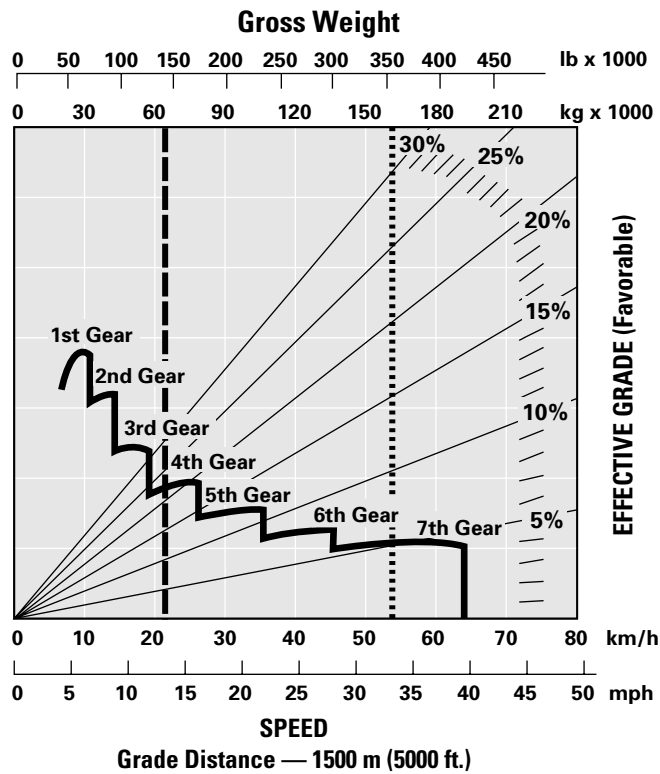
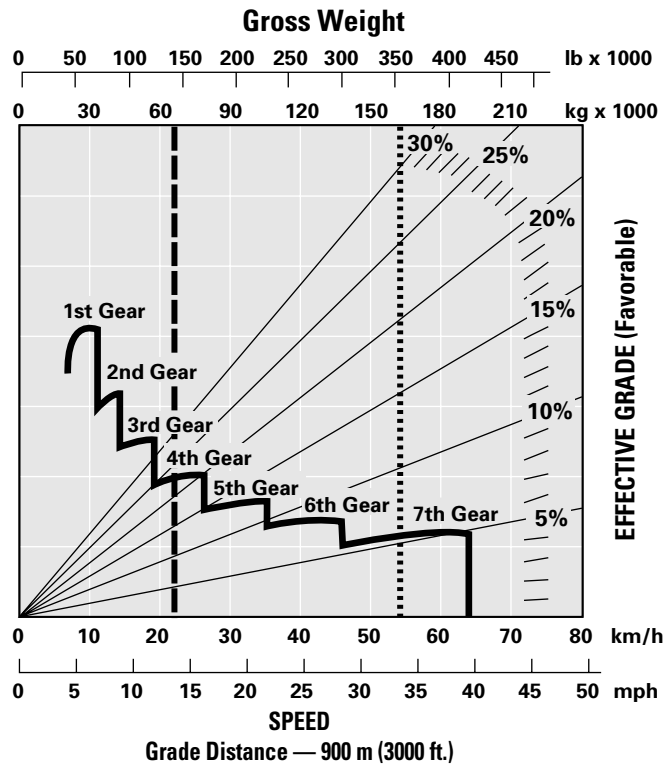

Retarding Performance

To determine retarding performance: Add lengths of all downhill segments and, using this total, refer to proper retarding chart. Read from gross weight down to the percent effective grade. Effective grade equals actual % grade minus 1% for each 10 kg/t (20 lb/ton) of rolling resistance. From this weight-effective grade point, read horizontally to the curve with the highest obtainable gear, then down to maximum descent speed brakes can properly handle without exceeding

cooling capacity. The following charts are based on these conditions: 32° C (90° F) ambient temperature, at sea level, with 27.00-R49 tires.

NOTE: Select the proper gear to maintain engine rpm at the highest possible level, without overspeeding the engine. If cooling oil overheats, reduce ground speed to allow transmission to shift to the next lower speed range.

- — — Typical Field Empty Weight
- Gross Machine Operating Weight
163 360 kg (360,143 lb)

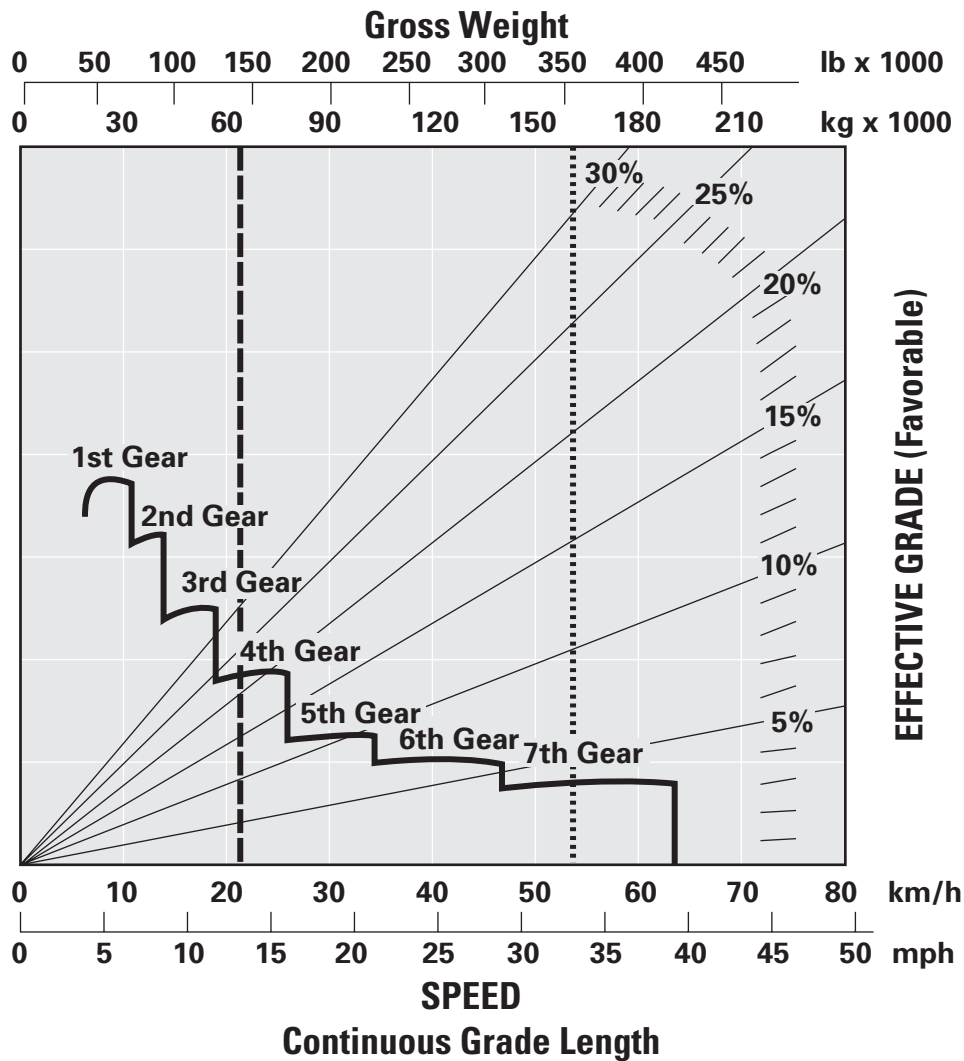

Standard Equipment

Standard equipment may vary. Consult your Caterpillar dealer for details.

Air Line Dryer
Alternator (100-amp)
Alarm, Back-up
Batteries, 190-amp hour, 12-volt (4)
Battery Disconnect Switch, ground level
Body Mounting Group
Body Safety Pins
Body Up Reverse Inhibitor
Braking System
 Brake Disconnect Switch, front
 Brake Heat Exchanger
 Brake Release Motor for Towing
 Oil-Cooled Multiple Disc Brakes (rear)
 Parking Brake
 Retarder
 Secondary Brake
Cab, ROPS
 Coat Hook
 Diagnostic Connector Port, 24-volt
 Electronic Monitoring System III
 Hoist Lever, finger tip-actuated
 Horn, air
 Insulated and Sound-Suppressed
 Power Port, 24-volt
 Product Link Ready
 Radio Ready, 5-amp converter, speakers, antenna, wiring
 Seat, Caterpillar Comfort, full air suspension
 Seat Belts, 75 mm (3 in) wide retractable
 Seat, Passenger
 Steering Wheel, tilt, padded, telescopic
 Storage Compartment
 Sun Visor
 Tinted Glass
 Window, electric (operator)
Coolant, Extended Life, -35° C (-30° F)
Crankcase Guard
Drive line Guard
Electrical System, 24-volt
Engine
 Cat 3508B Electronic Unit Injection
 8-Cylinder Diesel
 Turbocharged
 Aftercooled
 Air Cleaner with Precleaner (2)
 Automatic Cold Mode Idle Control
 Electric Start
 Engine Shutdown Switch, ground level
 Starting Aid, Ether
Filters, Spin-on

Gauges
 Actual Gear Indicator
 Air Cleaner Service Indicator
 Air Pressure
 Body Down Indicator
 Brake Oil Temperature
 Coolant Temperature
 Engine Overspeed Indicator
 Fuel Level
 Hour Meter
 Load Counter, automatic
 Odometer
 Speedometer
 Tachometer
Lighting System
 Auxiliary Jump Start Receptacle
 Back-up Lights
 Directional Signals and Hazard Warning, LED
 Dome/Courtesy Light
 Headlights, Halogen, with dimmer
 Stop and Tail Lights, LED
Mirrors, right/left
Reservoirs (separate)
 Brake/Converter/Hoist
 Steering
 Transmission/Torque Converter
Rims, 19.5 × 49
Rock Ejectors
Service Platform, bolt-on
Supplemental Steering, automatic
Tires, 27.00-R49, radial
Tow Hooks, front
Tow Pin, rear
Transmission
 7-Speed Automatic Power Shift, electronic control
 Body-up Shift Limiter
 Controlled Throttle Shifting
 Directional Shift Management
 Downshift/Reverse Shift Inhibitor
 Economy Shift Mode
 Engine Overspeed Protection
 Reverse Neutralizer During Dumping
 Neutral Coast Inhibitor
 Neutral Start Switch
 Programmable Top Gear Selection
Vandalism Protection Locks
Windshield Wipers and Washer, electric intermittent

Optional Equipment

Optional equipment may vary. Consult your Caterpillar dealer for details.

Air Conditioning	Lubrication Group – Automatic
Automatic Retarder Control (ARC), dry	Muffler
Body Tail End Liner	Muffler/Exhaust Diverter
Dual Slope	Wiggins Service Center
Fuel Fast Fill Adapter	
Fuel Tank	
Integrated Braking Control (IBC), dry	
Combines Traction Control System (TCS) and Automatic Retarder Control (ARC) into one system.	

Weight/Payload Calculation*

(Example)

	Dual Slope		Dual Slope w/Liner	
	kg	lb	kg	lb
CHASSIS				
Empty Chassis Weight + 10% fuel	48 600	107,144	48 600	107,144
Fuel Correction (90% × 300 × 7.1 lb/gal)	870	1,918	870	1,918
Optional Attachments Weight Debris Allowance (4% of chassis weight)	+1944	+4,286	+1944	+4,286
Total Chassis Weight	<u>51 414</u>	<u>113,347</u>	<u>51 414</u>	<u>113,347</u>
BODY				
Body Weight	16 070	35,428	16 070	35,428
Body Attachment Weights			5 432	11,975
Total Body Weight	<u>+16 070</u>	<u>+35,428</u>	<u>+21 502</u>	<u>+47,403</u>
Total Empty Operating Weight	<u>67 484</u>	<u>148,775</u>	<u>72 916</u>	<u>160,751</u>
Target Payload	<u>+95 876</u>	<u>+211,368</u>	<u>+90 444</u>	<u>+199,393</u>
Gross Machine Operating Weight	<u><u>163 360</u></u>	<u><u>360,143</u></u>	<u><u>163 360</u></u>	<u><u>360,143</u></u>

* Refer to Caterpillar's 10/10/20 Payload Policy for Quarry and Construction Trucks.

Notes

777D Off-Highway Truck

For more complete information on Cat products, dealer services,
and industry solutions, visit us on the web at www.cat.com

© 2007 Caterpillar
All Rights Reserved
Printed in U.S.A.

Materials and specifications are subject to change without notice.
Featured machines in photos may include additional equipment.
See your Caterpillar dealer for available options.

CAT, CATERPILLAR, their respective logos, "Caterpillar Yellow" and the
POWER EDGE trade dress, as well as corporate and product identity used herein,
are trademarks of Caterpillar and may not be used without permission.

AEHQ5855 (3-07)

CATERPILLAR[®]