

797B

Mining Truck



Engine

Engine Model	Cat® 3524B EUI	
Gross Power	2648 kW	3,550 hp
Flywheel Power	2513 kW	3,370 hp

Weights

Gross Machine	623 690 kg	1,375,000 lb
Operating Weight		

Operating Specifications

Nominal Payload	345 tonnes	380 tons
Capacity		

797B Mining Truck

Engineered for performance, designed for comfort, built to last.

Power Train - Engine

The Cat 3524B High Displacement engine delivers the power and reliability necessary to perform in the most demanding applications. Designed for efficient operation, the 3524B offers excellent fuel efficiency, lower emissions, reduced engine noise and lower operating costs. **pg. 4**

Power Train - Transmission

The Cat seven-speed power shift transmission and mechanical power train, matched with the electronic unit injection 3524B engine, provides consistent power and efficiency for peak power train performance. **pg. 5**

Engine/Power Train Integration

The Cat Data Link electronically combines engine, transmission, brake and operational information to optimize overall truck performance. Stored diagnostic data can be accessed via the Electronic Technician (ET) to improve troubleshooting and reduce downtime. **pg. 6**

Monitoring System

Vital Information Management System (VIMS) provides operators, service technicians and managers with vital machine health and payload data to keep the 797B performing at peak efficiency and top production levels while lowering cost-per-ton. **pg. 12**

Truck Body Systems

A variety of Caterpillar designed and built truck bodies ensure optimal performance and reliability in tough mining applications. Cat dealers can help build an optimum hauling system to maximize truck payloads and extend body and truck wear life. **pg. 14**

Serviceability

The 797B is designed for quick and easy servicing. Simplified service and maintenance features reduce downtime, allowing the machine to spend less time being serviced and more time on the haul roads. **pg. 16**

Top Performance.

Developed specifically for high production mining applications, the 797B Mining Truck keeps material moving at high volume to lower your cost-per-ton.

Reliable, Durable Operation.

Rugged construction and easy maintenance procedures ensure long life with low operating costs.



Caterpillar® Brake System

Cat oil-cooled, multiple disc brakes offer exceptional, fade-resistant braking and retarding for maximum performance and productivity in all haul road conditions. Integrated Braking Control combines retarding and traction control into one system for optimum braking efficiency. **pg. 8**

Structures

Caterpillar truck frames are built to optimize torsional load displacement. Mild steel provides flexibility, durability and resistance to impact loads. Castings and forgings in high stress areas provide exceptional strength and durability for long life. **pg. 10**

Operator's Station

The ergonomic cab is designed for operator comfort and ease of operation to allow the operator to focus on production. Controls and gauges are positioned within easy reach for optimum efficiency and superior control all shift long. **pg. 11**

Customer Support

Caterpillar dealers provide unmatched product support, anywhere in the world. With industry-best parts availability and a wide range of maintenance and service options, Cat dealers have what it takes to keep your mining machines productive. **pg. 17**

Safety

Caterpillar sets the standard when it comes to safety in the design and manufacturing of heavy equipment for the mining industry. Safety is not an afterthought at Caterpillar, but an integral part of all machine and systems designs. **pg. 18**



Power Train - Engine

The Cat 3524B High Displacement engine is built for power, reliability and efficiency for superior performance in the toughest applications.

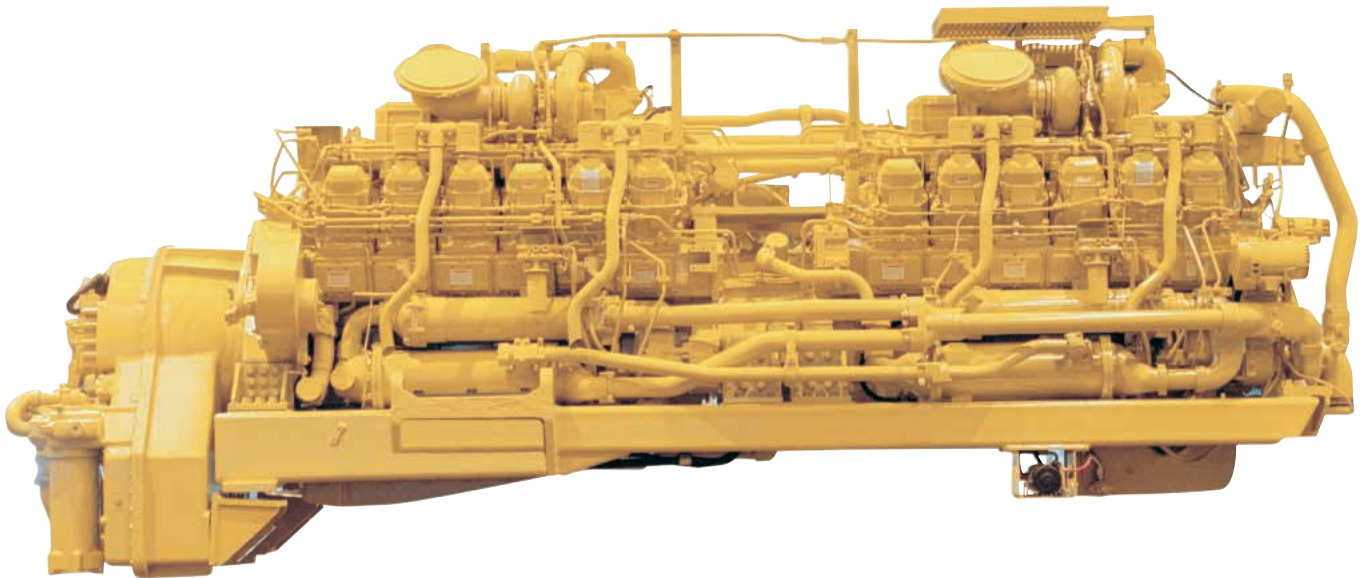

Engine. The Cat 3524B High Displacement EUI twin turbocharged and aftercooled diesel engine delivers high power and reliability in the world's most demanding mining applications.

Design. The 3524B engine is a tandem unit consisting of two 3512B HD engine blocks, coupled to perform as a single engine in terms of operation, monitoring and control. The 24-cylinder, dual engine design offers superior performance in relation to its size, weight and speed.

EPA Compliant. The 3524B engine is compliant with U.S. Environmental Protection Agency Tier I emissions standards.

Altitude Compensation. Designed for maximum operating efficiencies, the 3524B begins derating at 2591 m (8,500 ft) altitude and derates at 1% kPa.

Optional High Altitude Arrangement (HAA) does not derate between 3048-4572 m (10,000-15,000 ft).

High Torque Rise. The 22% net torque rise provides unequalled lugging force during acceleration, on steep grades and in rough underfoot conditions. Torque rise effectively matches transmission shift points for maximum efficiency and fast cycle times.

Enhanced Life. High displacement, low rpm rating and conservative horsepower ratings mean more time on the haul roads and less time in the shop.

Two-Piece Piston Design. Two-piece articulated pistons with a deep bowl, low volume crevice design enhances combustion efficiency, improves fuel efficiency and lowers emissions.

Electronic Unit Injection (EUI). The electronically controlled unit injection fuel system senses operating conditions and regulates fuel delivery for optimum fuel efficiency. The proven high-pressure fuel system provides improved response times and more efficient fuel burn with lower emissions and less smoke.

Electronic Control Module (ECM). ECM utilizes advanced engine management software to monitor, control and protect the engine utilizing self-diagnosing electronic sensors. The computerized system senses operating conditions and power requirements and adjusts engine for peak performance and most efficient operation at all times.

Separate Circuit Aftercooler. Allows the aftercooler circuit to operate cooler than jacket water temperature for a denser air charge and greater combustion efficiency.

Oil Renewal System. Optional oil renewal system extends engine oil change intervals from 500 to 4000 hours or more to increase machine availability and reduce cost.

Engine Protection. Computerized system electronically protects the engine during cold starts, high altitude operation, air filter plugging, and high exhaust temperature.

Power Train - Transmission

Cat mechanical power train delivers more power to the ground for greater productivity and lower operating costs.

Mechanical Power Train. The Cat mechanical drive power train and power shift transmission provides unmatched operating efficiency and control on steep grades, in poor underfoot conditions, and on haul roads with high rolling resistance.

Transmission. The Cat seven-speed planetary power shift transmission is matched with the direct-injection 3524B diesel engine to deliver constant power over a wide range of operating speeds.

Robust Design. The 797B transmission is the largest power shift transmission for trucks in the world. Specially designed to handle the high torque and horsepower of the 3524B engine, the proven planetary power shift transmission is built tough for long life between overhauls.

Transmission Chassis Control (TCC). TCC uses electronically transferred engine rpm data to execute shifts at preset points for optimum performance, efficiency and clutch life.

Lock-Up Torque Converter. Combines maximum rimpull and cushioned shifting of torque converter drive with the efficiency and performance of direct drive. Engages at approximately 6 km/h (4 mph), delivering more power to the wheels.

Final Drives. Cat final drives work as a system with the planetary power shift transmission to deliver maximum power to the ground. Built to withstand the forces of high torque and impact loads, double reduction final drives provide high torque multiplication to further reduce drive train stress.



Steering System. Hydraulic steering control system is designed for exceptional smoothness and precise control. A separate circuit prevents cross contamination for long life.

Supplemental Steering. Supplemental steering system uses pressure accumulators and allows up to three 90 degree turns in case of engine failure.

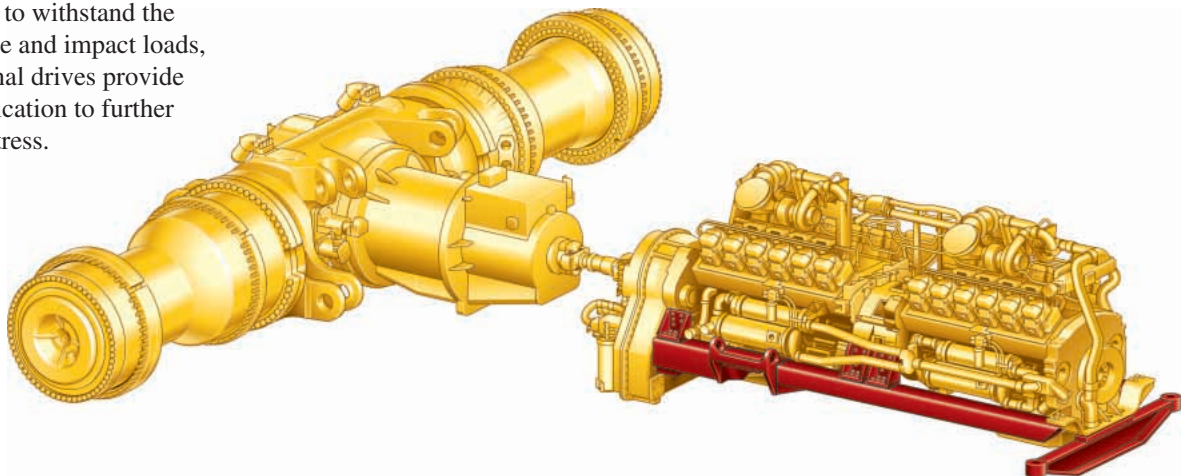

Engine/Power Train Integration

Electronically combines critical power train components to work more intelligently and to optimize overall truck performance.

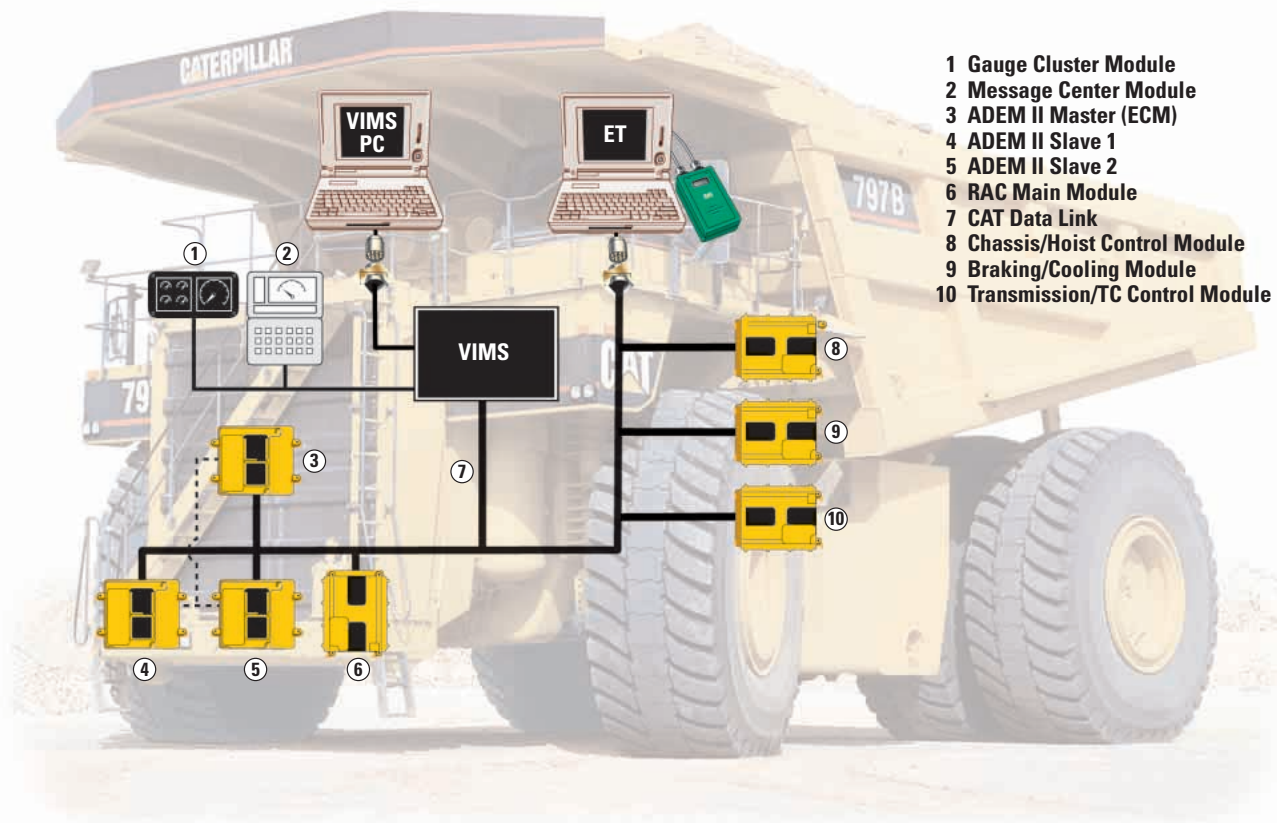

Cat Data Link. Electronically integrates machine computer systems to optimize overall power train performance, increase reliability and component life, and reduce operating costs.

Controlled Throttle Shifting (CTS). Regulates engine rpm during shifting to reduce power train stress and clutch wear by controlling engine speed, torque converter lock-up and transmission clutch engagement for smoother shifts and longer component life.

Electronic Clutch Pressure Control (ECPC). Works with Continuous Throttle Shifting to effectively manage the shift's torque and provide exceptional shift smoothness.

Directional Shift Management.

Regulates engine speed during directional shifts to prevent damage caused by high speed directional changes.

Neutral Coast Inhibitor. Prevents transmission from shifting to neutral at speeds above 6.5 km/h (4 mph) to protect the transmission from operating with insufficient lubrication.

Body-up Reverse Neutralizer. Automatically shifts the transmission to neutral if the hoist lever is activated while transmission is shifted in reverse.

Body-up Shift Inhibitor. Prevents the transmission from shifting above a pre-programmed gear without the body fully lowered.

Overspeed Protection. The transmission control electronically senses engine conditions and automatically up-shifts one gear to prevent overspeeding. If overspeeding occurs in top gear, the lock-up clutch is disengaged.

Programmable Top Gear. Transmission top gear maximum can be set using the ET service tool to help the operator maintain speed limits.

Anti-Hunt Function. Prevents gear hunting when operating near a shift point and minimizes shifts by not allowing an upshift or downshift immediately after a shift has occurred for increased component life.

Downshift Inhibitor. Prevents engine overspeeding by keeping the transmission from downshifting until engine speed reaches the downshift point.



Electronic Technician (ET). ET service tool provides service technicians with easy access to stored diagnostic data through the Cat Data Link to simplify problem diagnosis and increase machine availability.

Diagnostic Capability. Critical data from the electronic engine and transmission controls, including transmission shifting, engine speed and fuel consumption, provides service technicians with enhanced diagnostic capability to reduce downtime and operating costs.

Integrated Braking Control (IBC). IBC integrates Automatic Retarder Control and Traction Control into one system for optimum performance and efficiency.

Caterpillar Brake System

Reliable braking with superior control gives the operator the confidence to focus on productivity.



Integrated Braking System. The Cat oil-cooled braking system delivers reliable performance and control in the most extreme haul road conditions. The integrated system combines the service, secondary, parking brake and retarding functions in the same robust system for optimum braking efficiency.

Oil-Cooled Multiple Disc Brakes. Caterpillar four-wheel, forced oil-cooled, multiple disc service brakes are continuously cooled by water-to-oil heat exchangers for exceptional, non-fade braking and retarding performance.

Brake Design. Cat oil-cooled disc brakes are designed with large discs and plates for reliable, adjustment-free

operation and performance. Brakes are completely enclosed and sealed to prevent contamination and reduce maintenance.

Long Life. An oil film prevents direct contact between the discs. This design absorbs the braking forces by shearing the oil molecules and carrying heat away to extend brake life.

Pistons. The Caterpillar two-piston design combines the service, secondary, parking brake and retarding functions in the same system. The primary piston hydraulically actuates both service and retarding functions. The secondary piston is spring-applied and held in the disengaged position by hydraulic pressure. If hydraulic system pressure drops below a specified level, the spring-applied secondary piston automatically applies the brakes.

Parking Brake. Oil-cooled, spring-applied, hydraulically released parking brake is applied to all four wheels for superior parking capability on all grades up to 18 percent.

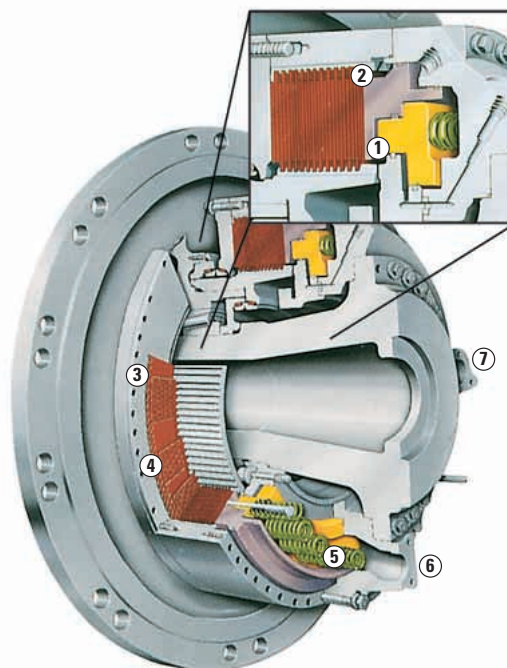

- 1 Parking/Secondary Piston
- 2 Service/Retarding Piston
- 3 Friction Discs
- 4 Steel Plates
- 5 Actuating Springs
- 6 Cooling Oil In
- 7 Cooling Oil Out

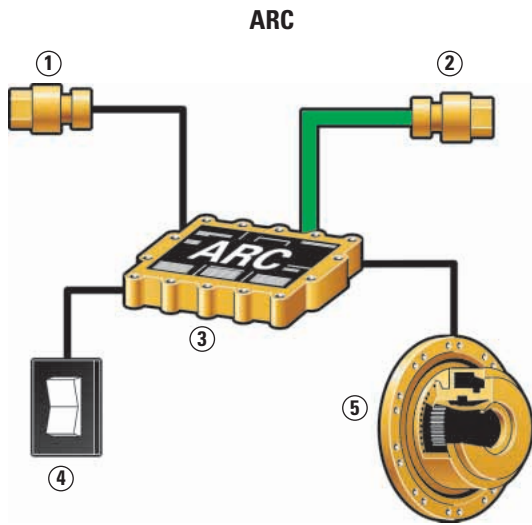

- 1 Service Brake Sensor
- 2 Engine Sensor
- 3 ARC
- 4 ARC Switch
- 5 Brakes
- 6 Service Brakes
- 7 Axle Speed Sensor
- 8 TCS

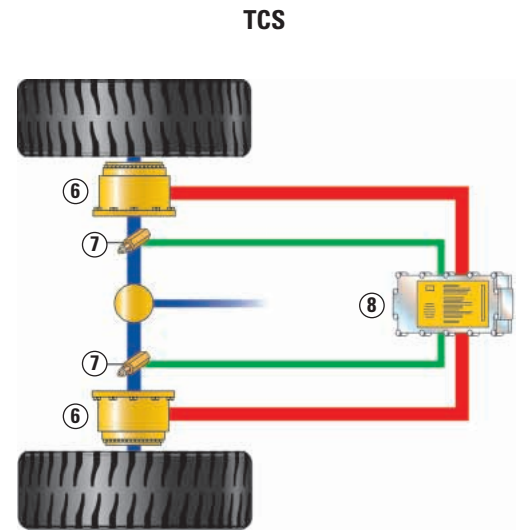

Automatic Retarder Control (ARC).

Electronically controls retarding on grade to maintain optimum engine rpm and oil cooling. Additional braking may be applied using the manual retarder or the brake pedal. ARC is deactivated when the operator applies the brakes or throttle.

ARC Operating Efficiency Advantages.

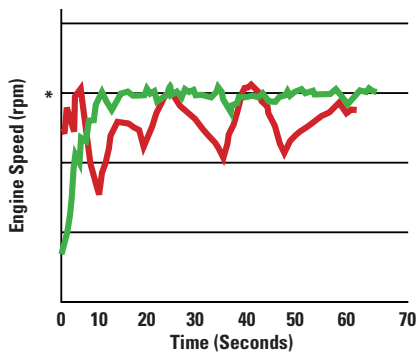

- Automatic Retarder Control (Maintains Engine rpm between 2160-2300)
- Manual Retarder Control (Wide Variation in Engine rpm)
- * Optimum Engine rpm

Faster Speeds. ARC allows the operator to maintain optimum engine speeds for faster downhill hauls and greater productivity.

Superior Control. Automatic brake modulation offers a smoother ride and better control in slippery conditions, allowing the operator to concentrate on driving.

Ease of Operation. ARC increases operating ease, resulting in greater operator confidence with less fatigue.

Engine Overspeed Protection. Automatically activates ARC when engine speed exceeds factory preset levels, regardless of operator inputs, to avoid potentially damaging engine overspeeds.

Four Corner Retarding. Four corner retarding with 60/40 percent split (rear/front) in braking effort provides superior control in slippery conditions. Balanced front to rear brake torque provides exceptional braking performance and minimizes wheel lock-up, especially during retarding.

Traction Control System (TCS).

Electronically monitors and controls rear wheel slippage for greater traction and enhanced truck performance in poor underfoot conditions. If slippage exceeds a set limit, the oil-cooled disc brakes engage to slow the spinning wheel. Torque is then automatically transferred to the wheel with better traction.

Integrated Braking Control (IBC). Combines Automatic Retarder Control (ARC) and Traction Control System (TCS) into one integrated brake control system for optimum efficiency, performance and reliability.

Cat Data Link. All control modules communicate via the Cat Data Link and work together as an integrated system to maximize production efficiency and extend component life.

Fuel Efficiency. The engine provides additional retarding by running against compression on downhill hauls. During retarding applications the engine ECM does not inject fuel into the cylinders for exceptional fuel economy.

Structures

Rugged Cat structures are the backbone of the 797B mining truck's durability.

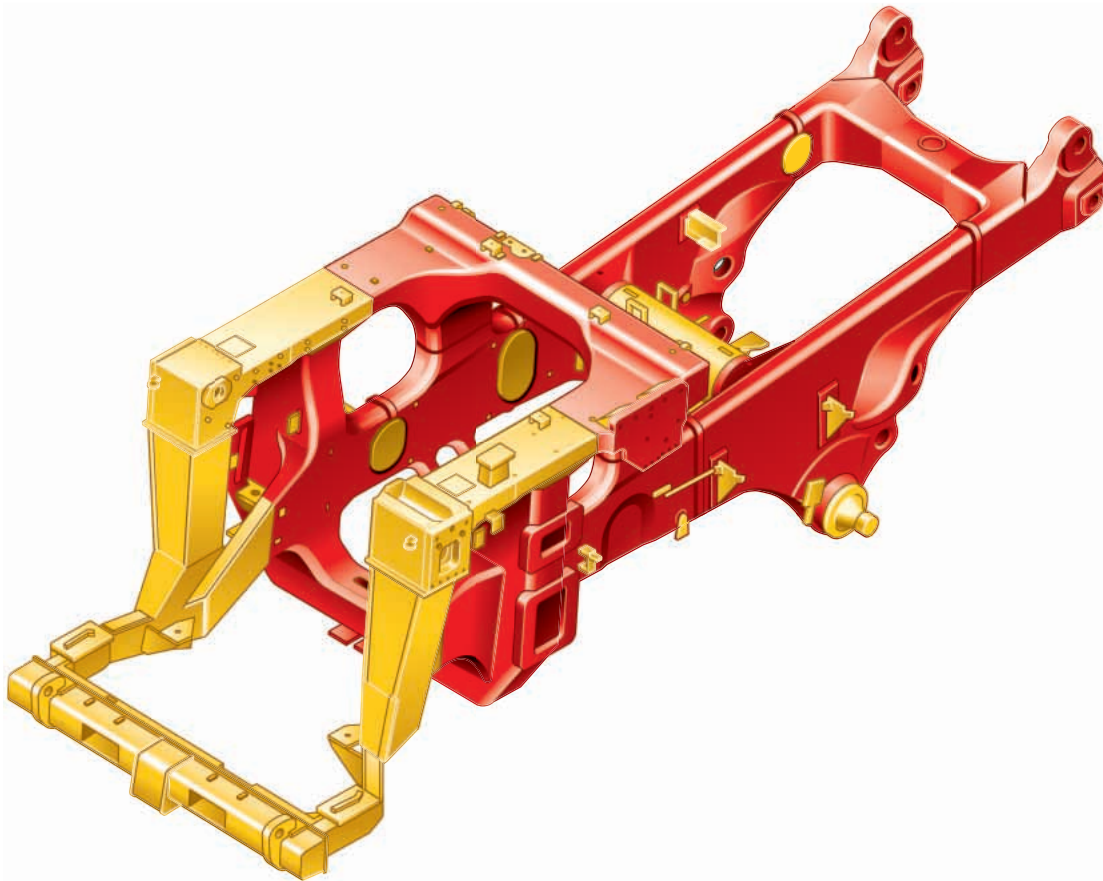

Frame Design. The 797B frame incorporates a box-section design and castings. Materials and weld joints are matched to optimize the life of this structure. In the main structural areas of the frame, full wall thickness butt-weld joints are used to maximize life.

Steel Structures. Mild steel used throughout frame provides flexibility, durability and resistance to impact loads, even in cold climates, and allows for easy field repairs.

Castings. Castings have large radii with internal reinforcing ribs to dissipate stress in areas of high stress concentration. The nine major castings are machined for precise fit before being joined using a robotic weld technology that ensures full penetration welds.

Fabrications. The lower stressed areas at the front of the frame are made of welded fabrications.

Rollover Protective Structure (ROPS). Integral to the cab, the four-post ROPS structure is resiliently mounted to the frame to reduce vibration and noise levels.

Suspension System. Uses oil-over-nitrogen struts to dissipate haul road and loading impacts for longer frame life and a more comfortable ride.

Cylinders. Four independent self-contained, oil pneumatic, variable-rebound suspension cylinders are designed to absorb shocks in the most severe applications.

• **Front.** Front cylinders with preset caster and camber are mounted to the frame and serve as steering kingpins for a tight turning radius with excellent maneuverability and low maintenance.

• **Rear.** Rear cylinders allow axle oscillation and absorb bending and twisting stresses caused by uneven and rough haul roads rather than transmitting them to the main frame.

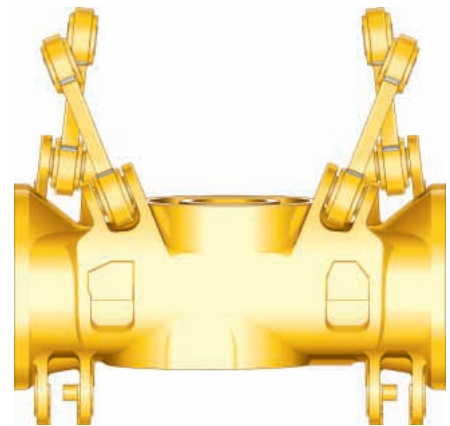

Rear Axle. Four-bar linkage connects the rear axle to the frame with maintenance free pins. The linkage directs the load onto the frame allowing it to be spread through the structure.

Operator's Station

Ergonomically designed for operator comfort, superior control and high productivity.

Ergonomic Layout. The 797B operator station is ergonomically designed for total machine control in a comfortable, productive and safe environment. All controls, levers switches and gauges are positioned to maximize productivity and minimize operator error.

Quiet Cab. Integral, sound-suppressed ROPS cab is resiliently mounted to the mainframe to isolate the operator from sound and vibration for a quiet, secure and comfortable ride.

Viewing Area. Designed for excellent all-around visibility and clear sight lines to the haul road, the large viewing area enables the operator to maneuver with confidence for high productivity.

1) Air Suspension Seats. Ergonomically designed, two fully adjustable air suspension seats with adjustable armrests provide optimal comfort for driver and trainer. Wide, retractable seat belts provide a secure, comfortable restraint.



2) Hoist Lever. Four-position electronic hoist system with fingertip control is mounted next to the operator's seat for easy operation.

3) Secondary Brake Pedal.

Conveniently located on the floor for easy operator control.

4) Monitoring System. VIMS features a high resolution display and easy-to-use operator input keypad for vital machine status information.

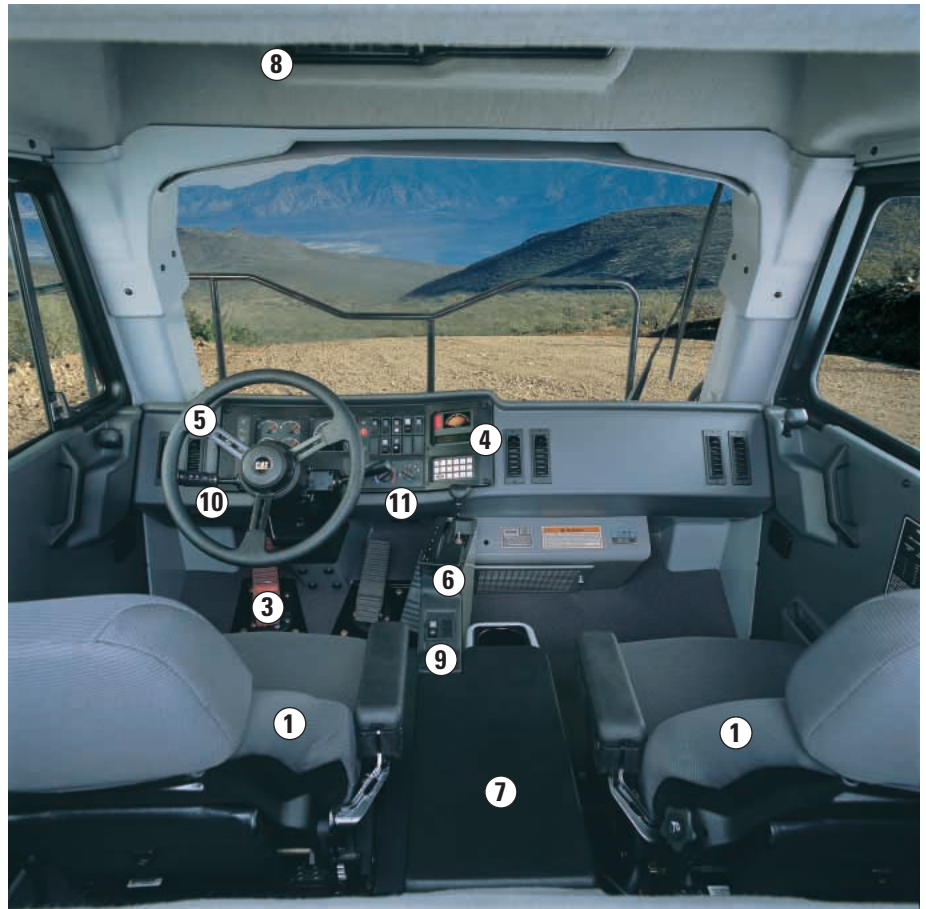

5) Steering Column. Sport wheel with tilt and telescopic steering provides a comfortable driving position and greater control.

6) Transmission Console. Ergonomic gear shift lever with backlit gear indicators optimize efficiency.

7) Storage Compartments. Two main storage compartments and door storage pockets provide an uncluttered work environment.

8) Overhead Console. Provides convenient access to rocker switches for lights: head, tail, parking, hazard, fog, backup, flood, and ladder lights.

9) Operator Window. Powered operator window offers simple operation and an unobstructed view.

10) Operator Controls. Easy to reach turn signal, high beam, intermittent windshield wiper and windshield washer controls are designed for optimum efficiency and comfort.

11) Heating/Air Conditioning. Electronically controlled four-speed fan and eleven vents deliver temperature-controlled air circulation for a comfortable working environment in any climate.

Radio Ready. Cab is prewired with power converter, speakers, wiring harness, antenna and provision for add-on communication systems.

Monitoring System

Vital machine health and payload data keeps the 797B performing at peak production levels.

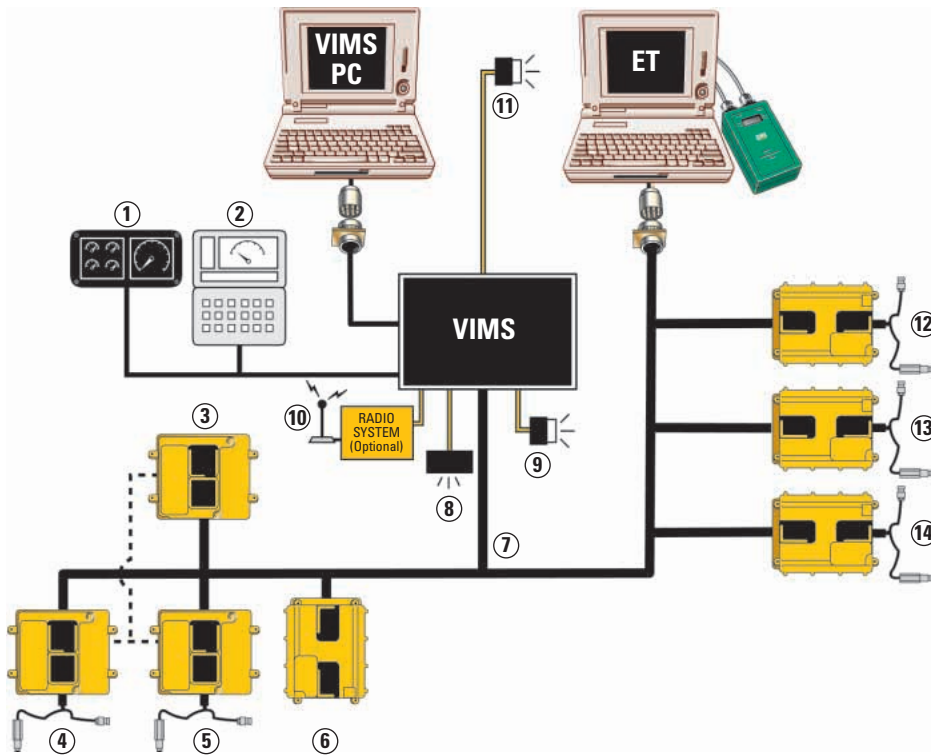

- 1 Gauge Cluster Module
- 2 Message Center Module
- 3 ADEM II Master (ECM)
- 4 ADEM II Slave 1
- 5 ADEM II Slave 2
- 6 RAC Main Module
- 7 CAT Data Link
- 8 Action Lamp
- 9 Action Alarm
- 10 Radio System (optional)
- 11 Service Lamp
- 12 Chassis/Hoist Control Module
- 13 Braking/Cooling Module
- 14 Transmission/TC Module

Vital Information Management System (VIMS). Intelligent Caterpillar designed machine monitoring system provides critical machine health and payload data in real-time to keep the 797B performing at top production levels.

Integrated System Monitoring. Sensors located throughout the machine systems enable VIMS to quickly exchange and monitor information from all machine systems for efficient, high performance operation.

Advanced Diagnostics. VIMS simplifies troubleshooting, reduces downtime and lowers operating costs by identifying abnormal conditions before they cause extensive damage.

Data Access. Monitoring and diagnostic information is stored on-board until it can be downloaded for analysis. Data can be accessed through the message center, transmitted via optional radio or downloaded onto a computer for detailed analysis.

Machine Management. Service technicians or mine management can download data and generate reports for better machine management. Data can be used to improve effectiveness of scheduled maintenance programs, maximize component life, improve machine availability, and lower operating costs.



Gauge Cluster. Maintains a constant display of vital machine functions, including:

- engine coolant temperature
- brake oil temperature
- torque converter outlet temperature
- fuel level



Speedometer/Tachometer Module. Monitors three systems: engine speed, ground speed and actual gear.



Message Center. Displays messages requested by operator and advises operator of abnormal machine conditions.

Keypad. Provides operator or service technician immediate access to current machine information, gauge values and stored data through the message center display.

Alert System. Three-category warning system alerts operator of abnormal machine health conditions.

- **Category I.** Machine or system needs attention.
- **Category II.** Requires operator to evaluate and correct situation before continuing work.
- **Category III.** Immediate shutdown required to prevent serious damage to machine or system.

Production Management. True Weight Production Management provides accurate production reporting by utilizing suspension strut pressure differentials and advanced algorithm to weigh the truck after it moves away from the loading tool and shifts into second gear. Production data enhances

truck and loading tool effectiveness and fleet productivity, and minimizes overloading to reduce downtime and lower operating and maintenance costs.

VIMS-PC. VIMS-PC, the off-board reporting software program, allows service personnel to download a complete record of machine health and productivity data to a laptop computer for diagnosis and analysis. Easy-to-use software enables service technicians and mine management to generate health and payload reports for more effective machine management.

VIMS Supervisor. Optional software allows mine management to easily manage and interpret VIMS data for optimum fleet management and productivity.

Payload Weight Distribution

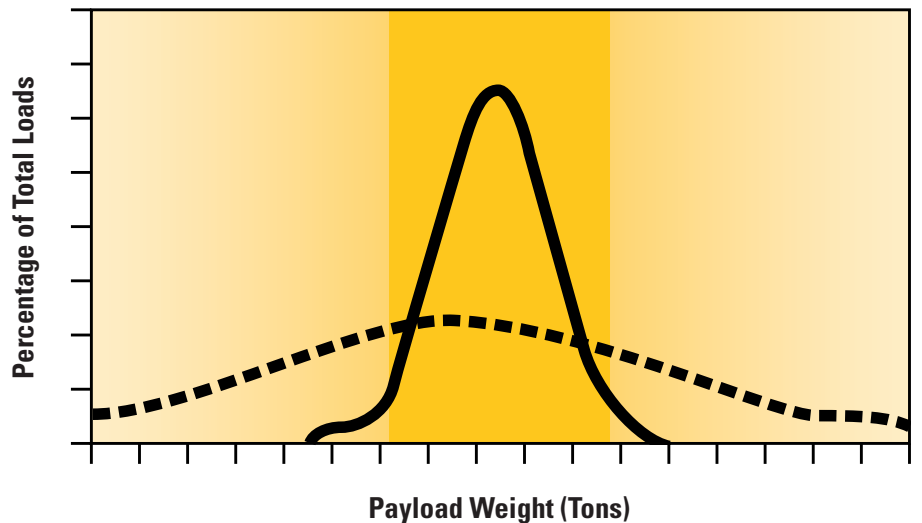

Recommended Payload Range
 Inefficient Payload Ranges

With Production Management
 Without Production Management

Truck Body Systems

Cat designed and built for rugged performance and reliability in the toughest mining applications.



Cat Truck Bodies. Caterpillar offers two specific body styles and custom body options for the most efficient hauling solutions at the lowest cost-per-ton.

- Flat Floor (Standard)
- Mine Specific Design (MSD)

Body Selection. Selection of the right body depends on material and haul road conditions. The better the match of body to application, the greater the efficiency. Your Cat dealer can help you select the right body system for your site specific application.

Body/Chassis Integration. Caterpillar truck bodies are designed and matched with the integrated chassis system for optimum structural reliability, durability and long life.

Electronic Hoist Control. Provides the operator with better control of the load when dumping, including over-center load control and modulated control throughout the operating range. The automatic body snubbing feature reduces impact on the frame, hoist cylinders and operator.

Fast Hoist Cycle Times. Two-stage hoist cylinders provide fast dump cycle times of 25 seconds for raise and 18.5 seconds for lower.

Body Design. Cat truck bodies are designed for optimal strength, capacity and durability. Wear surfaces are equipped to handle even the toughest impact and abrasion over the long haul without diminishing capacity.

- Wide Ribs in body floor provide increased durability and impact support.
- Full-Length Stringers create strength and rigidity throughout the bed.
- Box Section Beams offer increased durability in the floor, sidewall, top rail, corner, and cab canopy areas.
- Extended Top Rails made of rolled steel guard against impact caused by the loading tool or falling material.



1) Flat Floor Body. The flat floor design with slight incline delivers excellent payload capacity, high dump clearances and smooth, controlled dumping.

- Flat floor design provides consistent wear characteristics on body tail.
- 12 degree forward body slope provides good load retention on better maintained haul roads.
- 400 Brinell steel on surfaces provides excellent wear.



2) Mine Specific Design (MSD) Body. The MSD body is based on the flat floor design and is customized to maximize payload potential and minimize cost-per-ton. Each MSD body design begins with a detailed mine site profile to develop a body suitable for a mine's individual needs.



Custom Body Options. Tail extensions, sideboards, tumblebars, rock boxes and rock shredders are available to maintain rated payload, reduce spillage, and improve hauling efficiencies.

- Sideboards are designed to maximize or attain gross machine weight.
- Tail extensions are used to help retain the rear portion of the pile and limit load spillage on haul roads, extending tire life.

Body Liners. A variety of liner options for high wear areas are available to save weight and help extend the body system's life. Wear surfaces and liners are equipped to handle tough impact loads while resisting abrasion. Optional impact plates are designed to deliver long life in high impact areas.

Serviceability

Less time spent on maintenance means more more time on the haul roads.



Servicing Ease. Easy access to daily service points simplifies servicing and reduces time spent on regular maintenance procedures. Enhanced serviceability and 500-hour service intervals are designed to increase machine availability and productivity.

Maintenance Platform. Provides access to engine, air filters and battery compartment.

In-Frame Access. Permits easy access to major components for easy servicing and removal.

Ground-Level Access. Allows convenient servicing to tanks, filters, drains, and engine shutdown. Ground-level VIMS data port permits easier downloading of information.

Autolube. Automatic lubrication system reduces maintenance time by automatically lubricating necessary components on a regular basis.

Fast Fill Service Center. Wiggins fast fill service center features high speed fuel, coolant and oil exchange.

Oil Renewal System (ORS). Optional system extends oil change intervals and reduces waste oil handling by continuously burning oil from the engine oil pan through normal engine operation. Make-up oil must be continually added to compensate for oil burned.

Scheduled Oil Sampling. S•O•SSM sampling valves speed sampling and analysis reliability.

Pressure Test Points. Disconnect valves are conveniently located throughout the hydraulic systems for easy pressure testing.

Air Filters. Radial seal air filters are easy to change, reducing time required for air filter maintenance.

Sealed Electrical Connectors. Electrical connectors are sealed to lock out dust and moisture. Harnesses are braided for protection. Wires are color coded for easy diagnosis and repair.

Cylinder Heads. Individual cylinder heads are interchangeable for easy removal and visual inspection of internal parts.

On-Board Diagnostic Systems. VIMS continuously checks all critical machine functions and components, and helps locate faults quickly for faster repair. Electronic control system enables quick diagnosis of engine conditions and effective maintenance and repairs utilizing the Electronic Technician (ET) service tool.

Customer Support

Caterpillar dealers have what it takes to keep mining haul trucks productive.

Machine Selection. Make detailed comparisons of the machines under consideration before purchase. Cat dealers can estimate component life, preventive maintenance cost, and the true cost of lost production.

Purchase. Look past initial price. Consider the financing options available, as well as day-to-day operating costs. This is also the time to look at dealer services that can be included in the cost of the machine to lower equipment owning and operating costs over the long run.

Financing. Your dealer is an expert at arranging affordable financing options for all Caterpillar products.

Product Support. You will find nearly all parts at your dealer parts counter. Cat dealers use a worldwide computer network to locate in-stock parts to minimize machine downtime. Save money with Cat Reman parts. Receive the same warranty and reliability as new products at a savings of 40 to 70 percent.

Literature Support. Operation and maintenance manuals are easy to use, helping you get the full value of your equipment investment.

Customer Support Agreements. Cat dealers offer a variety of product support agreements, and work with customers to develop a plan that meets specific needs. Plans can cover the entire machine, including attachments, to help protect your investments.



Operation. Improving operating techniques can boost your profits. Your Cat dealer has training videotapes, literature and other ideas to help you increase productivity.

Replacement. Repair, rebuild or replace? Your Cat dealer can help you evaluate the cost involved so you can make the right choice.

Technology Products. Cat dealers offer a range of advanced mining technology products for customers, dealers and operators designed to improve fleet efficiency, increase productivity and lower costs.

www.CAT.com. For more complete information on Cat products, dealer services, and industry solutions, visit us on the web at www.CAT.com.

Safety

Caterpillar mining machines and systems are designed with safety as the first priority.

Product Safety. Caterpillar has been and continues to be proactive in developing mining machines that meet or exceed safety standards. Safety is an integral part of all machine and systems designs.

SAE and ISO Standards. The 797B is designed to national and international standards, and has been tested and self certified to applicable SAE and ISO standards.

Integral ROPS Cab. Resiliently mounted to the main frame to reduce vibration and sound, the integral ROPS structure is designed as an extension of the truck frame. The ROPS/FOPS structure provides “five sided protection” for the operator.

Ladder/Secondary Egress. A wide, stationary stairway with handrail on both sides allow three point contact access to and from the machine. A ladder on the left side of the machine permits secondary access or emergency egress.

Brake Systems. Four corner oil-cooled braking system provides excellent braking control in slippery conditions. The service brakes and retarding system are actuated by modulated hydraulic pressure, while secondary and parking brake functions are spring applied and hydraulic released. This system assures braking in the event of complete hydraulic failure.

Steering System. A twin double-acting cylinder steering system is designed to deliver precise control under various loading and underfoot conditions. The steering hydraulic system is separate from the main hydraulic system to prevent cross-contamination and overheating from other sources.



Engine Shut Off Switches. Located in the engine compartment and at ground level for an immediate shutdown.

Electrical System Disconnect. A disconnect switch, located outside the battery compartment, locks out the electrical system.

Payload Policy. Safety is integral to maintaining the highest productivity in mining machine operation. Caterpillar’s 10/10/20 Payload Policy assures that steering and braking systems have sufficient capacity to perform, even at 20% overload.

Standard Safety Features. Additional standard safety features include:

- Slip resistant surfaces
- Retractable, 75 mm (3 in) wide seat belts
- Wide-angle mirrors
- Body raised indicator
- Guard rails
- Reverse neutralizer when dumping
- Low interior sound level

Engine

Engine Model	Cat 3524B EUI	
Gross Power	2648 kW	3,550 hp
Flywheel Power	2513 kW	3,370 hp
Net Power - Cat	2513 kW	3,370 hp
Net Power - ISO 9249	2513 kW	3,370 hp
Net Power - SAE J1349 (6/95)	2513 kW	3,370 hp
Net Power - EEC 80/1269	2513 kW	3,370 hp
Bore	170 mm	6.7 in
Stroke	215 mm	8.5 in
Displacement	117.1 L	7,143 in ³

- Net power advertised is the power available at rated speed of 1750 rpm, measured at the flywheel when the engine is equipped with fan, air cleaner, muffler and alternator.
- Ratings based on standard air conditions of 25° C (77° F) and 99 kPa (29.32 Hg) dry barometer. Power based on fuel having API gravity of 35 at 16° C (60° F), LHV of 42,780 kJ/kg (18,390 BTU/lb), and density of 838.9 g/L (7.001 lb/gal) when engine used at 30° C (86° F).
- No engine derating required up to 2591 m (8,500 ft) altitude.
- Compliant with U.S. Environmental Protection Agency Tier 1 emissions standards.
- 24-cylinder, 4-stroke, high pressure unit injection engine.
- Full electronic controls with automatic engine derate.
- Two-piece pistons with steel crowns, thermally isolated aluminum skirts cooled by dual oil spray. Hardened crankshaft journals.
- Dry-type air cleaners and pre-cleaner.
- 24-volt electrical system with two 75-amp alternators and two 93-amp, low maintenance, high-output, 12-volt batteries.

Weights - Approximate

Gross Machine Operating Weight	623 690 kg	1,375,000 lb
Chassis Weight	214 820 kg	473,600 lb
Body Weight Range	38 000 - 63 000 kg	84,000 - 140,000 lb

- Chassis weight with hoist, body mounting group and tires.
- Body weight varies depending on how body is equipped.

Operating Specifications

Nominal Payload Capacity	345 tonnes	380 tons
Top Speed - Loaded	67.6 kph	42 mph
Maximum Capacity	Custom	
Steer Angle	39°	
Turning Radius - Front	39.9 m	130.9 ft
Turning Circle Clearance Diameter	40.5 m	132.8 ft

Transmission

Forward 1	11.3 kph	7 mph
Forward 2	15.2 kph	9.5 mph
Forward 3	20.5 kph	12.7 mph
Forward 4	27.7 kph	17.2 mph
Forward 5	37.2 kph	23.1 mph
Forward 6	50.3 kph	31.2 mph
Forward 7	67.6 kph	42 mph
Reverse	12.9 kph	8 mph

- Maximum travel speeds with standard 59/80R63 tires.
- Caterpillar seven-speed, electronically controlled, automatic power shift transmission.
- Reverse and Forward 1 gears are both torque converter driven with lock-up in Forward 1 through Forward 7.
- Each shift individually modulated for maximum smoothness.
- Controlled Throttle Shift and Directional Shift Management maximize shift smoothness and minimize drive line stress.
- Single-lever shift control provides automatic shifting in all gears.

Final Drives

Differential Ratio	1.265:1
Planetary Ratio	16.67:1
Total Reduction Ratio	21.09:1

- Double reduction, planetary, with full-floating axles.

Brakes

Brake Surface - Front	132 258 cm ²	20,500 in ²
Brake Surface - Rear	198 387 cm ²	30,750 in ²
Standards	J-ISO 3450 JAN88, ISO 3450-1996	

- Maximum operating weight up to 623 690 kg (1,375,000 lb).
- Service Brakes. Forced oil-cooled/variable capacity disc brakes with electro-hydraulic controls. Sealed and individually serviceable.
- Parking Brakes. Spring-applied, hydraulically released; toggle switch activated. Uses same disc brakes as service brakes.
- Secondary Brakes. Spring-applied, hydraulically released.
- Retarding System. Automatic Retarder Control standard. Applied to all wheels (40/60 split, front and rear). Hand operated lever provides modulated engagement of service brakes for retarding.
- Traction System. Traction Control System standard.

Body Hoists

Pump Flow - High Idle	1225 L/min	323 gal/min
Pump Flow - Low Idle	1099 L/min	290 gal/min
Relief Valve Setting - Raise	23 787 kPa	3,450 psi
Body Raise Time - High Idle	25 Seconds	
Body Lower Time - High Idle	18.5 Seconds	
Body Power Down - High Idle	17.3 Seconds	
Body Raise Time - Low Idle	25 Seconds	
Body Lower Time - Low Idle	18.5 Seconds	
Body Power Down - Low Idle	18.1 Seconds	

- Twin, two-stage hydraulic cylinders, mounted outside main frame.
- Power raise in both stages; power down in first stage.
- Automatic body-lower modulation reduces impact on frame.

Weight Distributions - Approximate

Front Axle - Empty	43.5 %
Rear Axle - Empty	56.5 %
Front Axle - Loaded	33.3 %
Rear Axle - Loaded	66.7 %

Service Refill Capacities

Fuel Tank	6814 L	1,800 gal
Cooling System	1194 L	315 gal
Crankcase	417 L	110 gal
Differentials and Final Drives	701 L	185 gal
Steering Tank	235 L	62 gal
Steering System (Includes Tank)	432 L	114 gal
Brake/Hoist Hydraulic Tank	996 L	263 gal
Brake/Hoist System (Includes Tank)	1842 L	486 gal
Torque Converter/Transmission Sump	190 L	50 gal
Torque Converter/Transmission System (Includes Sump)	629 L	166 gal

ROPS

ROPS Standards	SAE J1040 APR88, SAE J231 JAN81, ISO 3471-1994, ISO 3449-1992 Level II
----------------	---

- ROPS (Rollover Protective Structure) for cab offered by Caterpillar meets SAE J1040 APR88, SAE J231 JAN81, ISO 3471-1994, ISO 3449-1992 Level II ROPS criteria.

Sound

Sound Standards	ANSI/SAE J1166 MAY90, ANSI/SAE J88 JUN86
-----------------	---

- The operator sound exposure Leq (equivalent sound pressure level) measured according to work cycle procedures specified in ANSI/SAE J1166 MAY90 is less than 76 dB(A) for cab offered by Caterpillar, when properly installed and maintained and tested with doors and windows closed.
- Hearing protection may be needed when operating with an open operator station and cab (when not properly maintained or doors/windows open) for extended periods or in a noisy environment.

Steering

Steering Standards	SAE J1511 OCT90, ISO 5010-1984
--------------------	-----------------------------------

- Maximum operating weight up to 623 690 kg (1,375,000 lb).
- Separate hydraulic system prevents cross contamination.
- Secondary steering provided by bladder-type accumulator.
- Twin, double-acting cylinders.
- Front suspension cylinders serve as kingpins.

Tires

Standard Tire	59/80R63
---------------	----------

- Productive capabilities of the 797B truck are such that, under certain job conditions, TKPH (TMPH) capabilities of standard or optional tires could be exceeded and, therefore, limit production.
- Caterpillar recommends the customer evaluate all job conditions and consult the tire manufacturer for proper tire selection.

Dimensions

All dimensions are approximate.

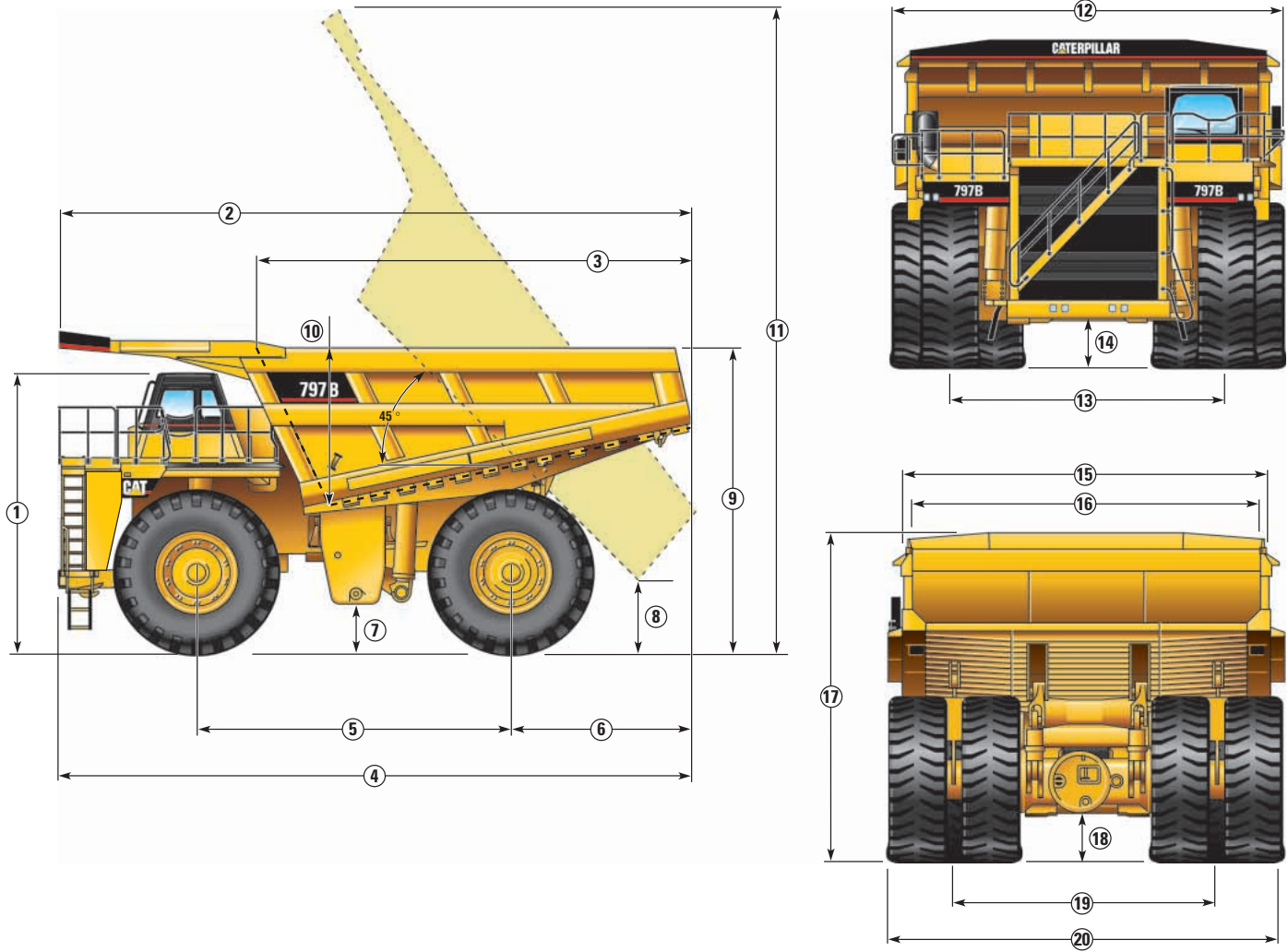

1	Height to Top of ROPS - Full	6351 mm	250 in
1	Height to Top of ROPS - Empty	6549 mm	258 in
2	Overall Body Length	14 483 mm	569 in
3	Inside Body Length	9941 mm	391 in
4	Overall Length	14 530 mm	572 in
5	Wheelbase	7200 mm	283 in
6	Rear Axle to Tail	4016 mm	158 in
7	Ground Clearance - Full	869 mm	34 in
7	Ground Clearance - Empty	1059 mm	42 in
8	Dump Clearance	1885 mm	74 in
9	Loading Height - Empty	7083 mm	278 in
10	Inside Body Depth - Max	3350 mm	132 in

11	Overall Height - Body Raised	15 292 mm	602 in
12	Operating Width	9154 mm	360 in
13	Centerline Front Tire Width	6512 mm	256 in
14	Engine Guard Clearance - Full	919 mm	36 in
14	Engine Guard Clearance - Empty	1122 mm	44 in
15	Outside Body Width	8524 mm	336 in
16	Inside Body Width	8000 mm	315 in
17	Front Canopy Height	7584 mm	299 in
18	Rear Axle Clearance - Full	951 mm	37 in
18	Rear Axle Clearance - Empty	1046 mm	41 in
19	Centerline Rear Dual Tire Width	6233 mm	245 in
20	Overall Tire Width - Full	9761 mm	384 in

Retarding Performance

To determine retarding performance: Add lengths of all downhill segments and, using this total, refer to proper retarding chart. Read from gross weight down to the percent effective grade. Effective grade equals actual % grade minus 1% for each 10 kg/t (20 lb/ton) of rolling resistance. From this weight-effective grade point, read horizontally to the curve with the highest obtainable gear, then down to maximum descent speed brakes can properly handle without exceeding

cooling capacity. The following charts are based on these conditions: 32° C (90° F) ambient temperature, at sea level, with 59/80R63 tires.

NOTE: Select the proper gear to maintain engine rpm at the highest possible level, without overspeeding the engine. If cooling oil overheats, reduce ground speed to allow transmission to shift to the next lower speed range.

- Typical Field Empty Weight
- - - - - Gross Machine Operating Weight
623 690 kg / 1,375,000 lb

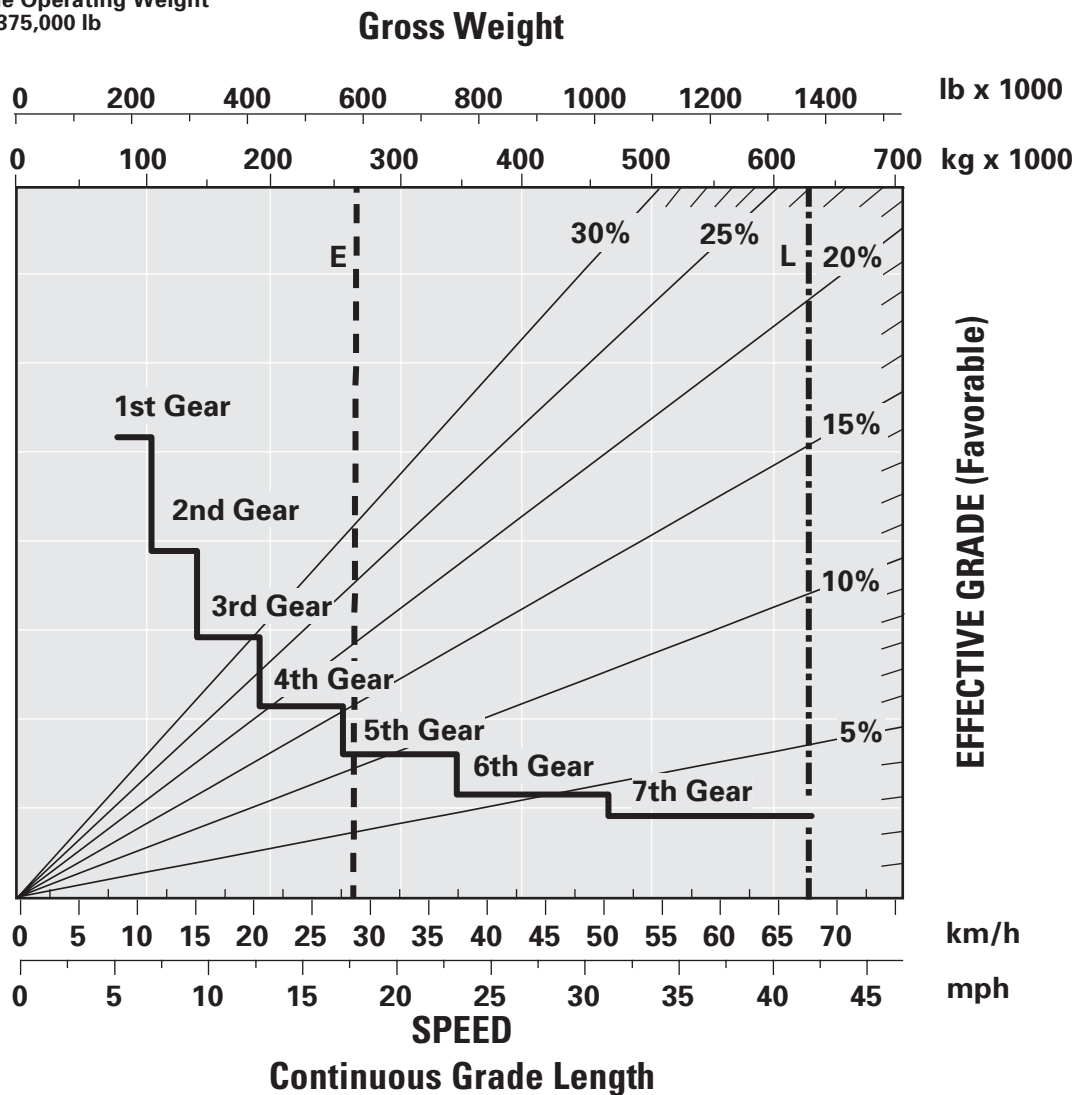

Retarding Performance

- - - Typical Field Empty Weight
 - - - - Gross Machine Operating Weight
 623 690 kg/1,375,000 lb

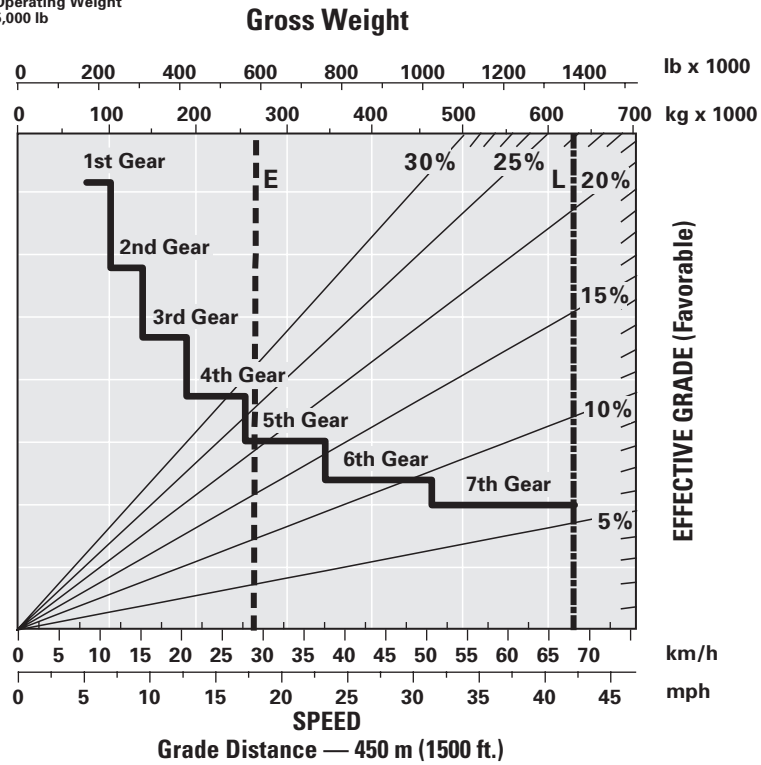

- - - Typical Field Empty Weight
 - - - - Gross Machine Operating Weight
 623 690 kg/1,375,000 lb

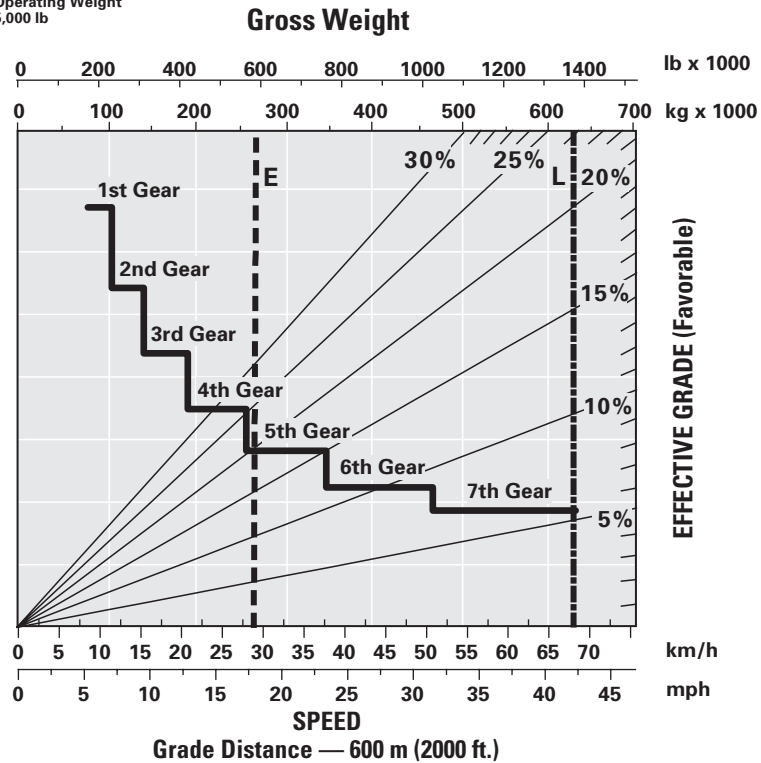

Retarding Performance

- - - Typical Field Empty Weight
 - - - Gross Machine Operating Weight
 623 690 kg/1,375,000 lb

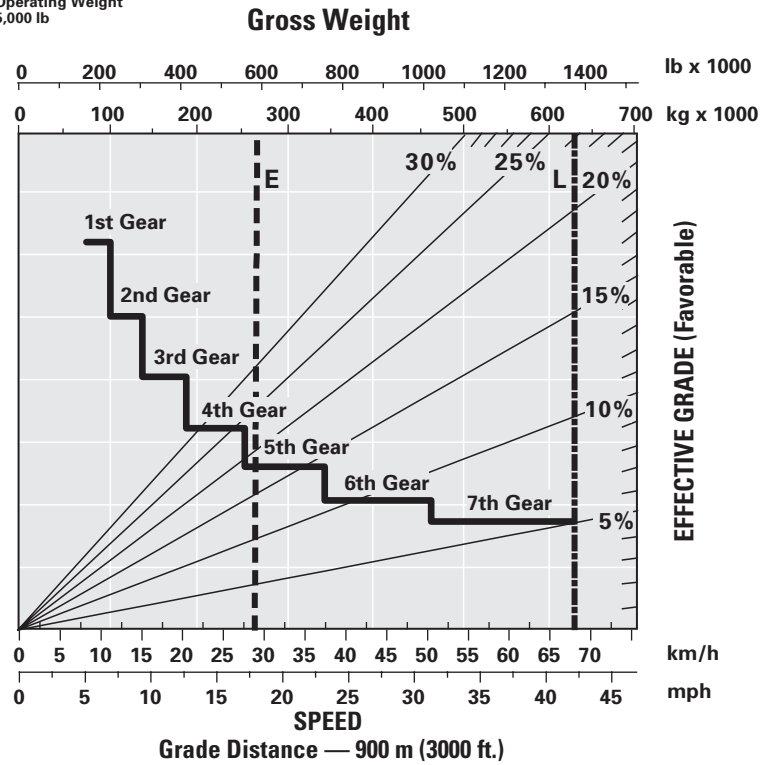

- - - Typical Field Empty Weight
 - - - Gross Machine Operating Weight
 623 690 kg/1,375,000 lb

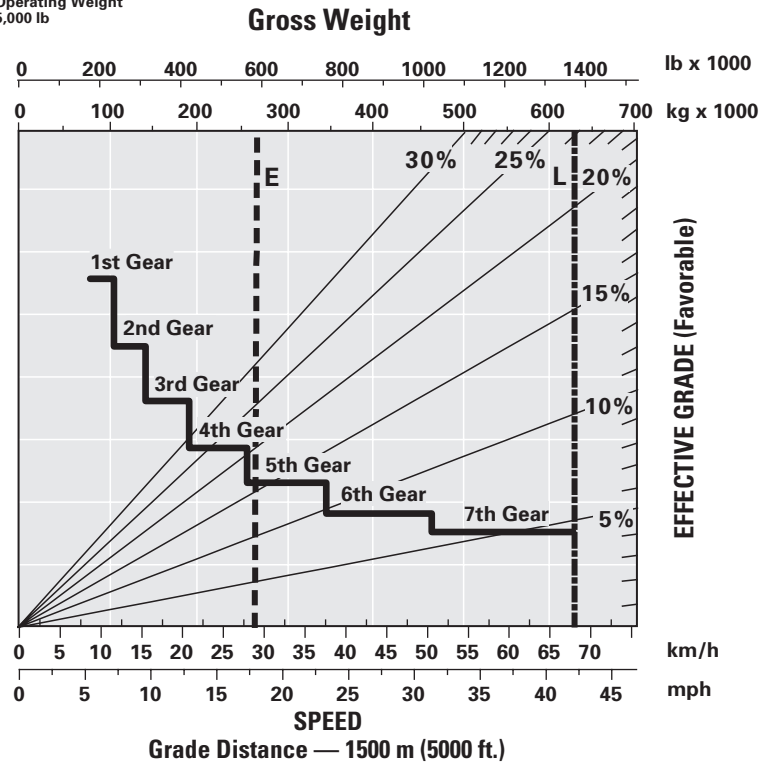

Gradeability/Speed/Rimpull

To determine gradeability performance: Read from gross weight down to the percent of total resistance. Total resistance equals actual percent grade plus 1% for each 10 kg/t (20 lb/ton) of rolling resistance. From this weight-resistance point, read

horizontally to the curve with the highest obtainable gear, then down to maximum speed. Usable rimpull will depend upon traction available and weight on drive wheels.

- Typical Field Empty Weight
- Gross Machine Operating Weight
623 690 kg/1,375,000 lb
- Torque Converter Drive
- Direct Drive
- * At Sea Level

Standard Arrangement* 59/80R63 Tires Gross Weight

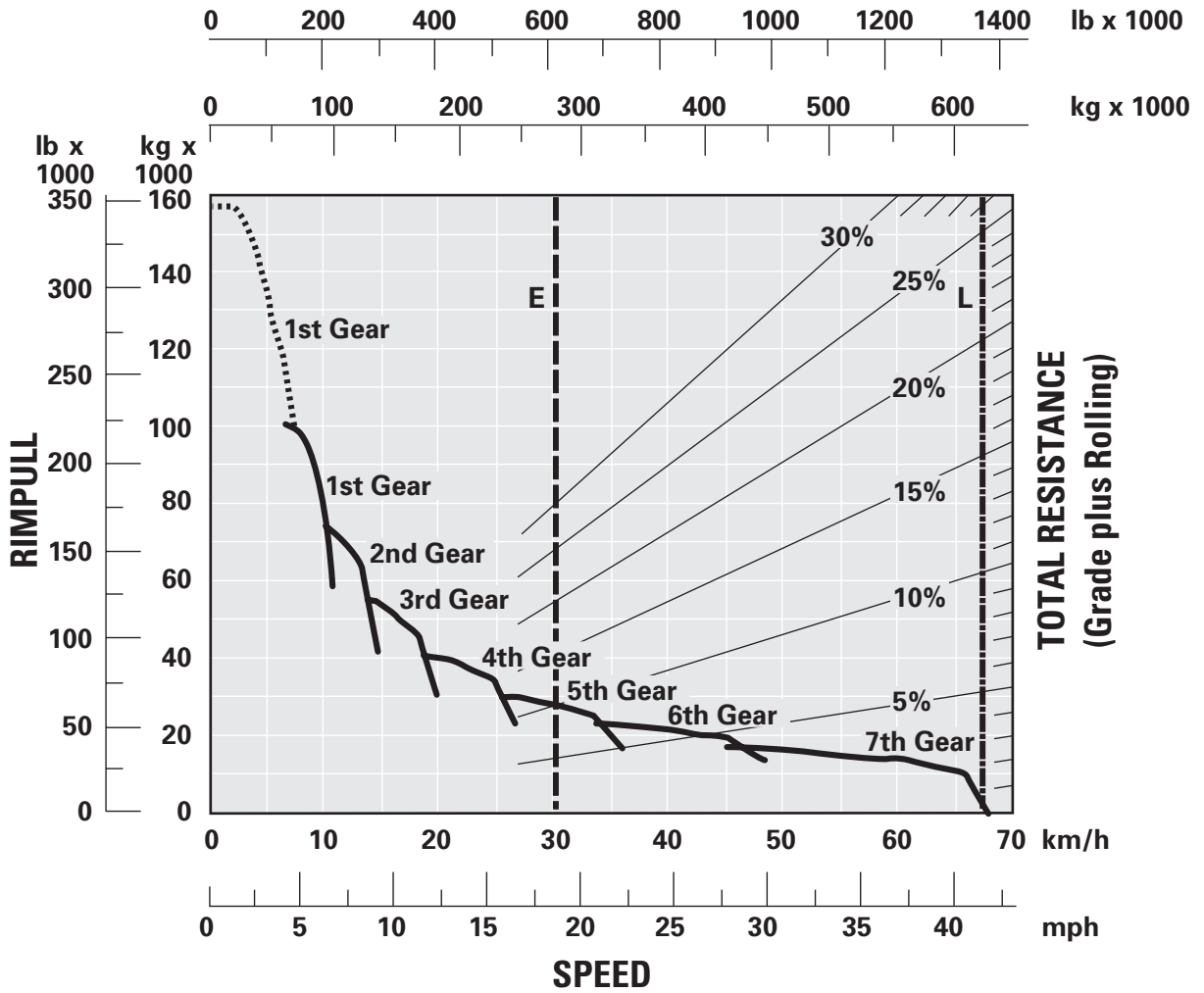

Standard Equipment

Standard equipment may vary. Consult your Caterpillar dealer for details.

Air Line Dryer	Engine - Caterpillar 3524B HD EUI Diesel Engine
Alarm, Back-up	Air Cleaner w/Precleaner (5)
Alternator, 75 amp (2)	Automatic Starter Protection
Antifreeze, Extended Life Coolant	Crankcase Protection
Automatic Lubrication System (Lincoln)	Elevated Low Idle Control
Automatic Retarder Control	Ether Starting Aid (Semi-automatic)
Auxiliary "Buddy" Dumping Quick Connect	Multi-point Oil Pressure Sensing
Body Mounting Group	Turbocharging (4)/Aftercooled
Brake System	Fast-fill Fuel System, Wiggins
Brake Release Motor for Towing	Ground Level
Oil-cooled, Multiple-disc, Front and Rear	Battery Disconnect
Parking	Engine Shutdown
Secondary, Emergency	VIMS Dataport
Cab, ROPS, Insulated/Sound Suppressed	High Speed Crankcase Oil Change (Wiggins)
Accessory Plug-in, 12V	Lighting System
Air Cleaner Service Indicator	Back-up Lights (4)
Air Conditioner	Engine Compartment Light
Ashtray	Direction Signals (Front/Rear LED's)
Cigarette Lighter	Fog Lights (4)
Coat Hook	Front Stair Access and Service Deck Lights
Dome Courtesy Light	Headlights, With Dimmer
Electric Window (Operator Only)	Stop and Tail Lights (LED)
Glass, Tinted	Reservoirs (Separate)
Heater/defroster: 11 070 kCal (43,930 Btu)	Brake
Horn	Converter
Mirrors, Right and Left	Hoist/Steering/Transmission
Quad-Gauge Panel	Rims, Center Mounted for 59/80R63 Tires
Brake Oil Temperature	Rock Ejectors
Coolant Temperature	Steering, Auxiliary Quick Connect for Towing
Fuel Level	Tie Down Eyes
Steering Oil Level	Tow Hooks, Front
Seat, Air Suspension	Tow Pin, Rear
Seat, Passenger, Air Suspension with	Traction Control System
Storage Compartments	Transmission
Seat Belts, 75 mm (3 in) wide retractable	7-speed, Auto Powershift w/ECPC Controls
Speedometer	Body Load Counter
Stairway Access	Body-up Reverse Neutralizer
Steering, Automatic Supplemental	Body-up Shift Inhibitor
Steering Wheel, Tilt, Telescopic	Controlled Throttle Shifting
Sun Visor	Directional Shift Management
Tachometer, Electronic	Downshift/Reverse Shift Inhibitor
Transmission Gear Indicator	Neutral Coast Inhibitor
VIMS Keypad	Neutral Start Switch
VIMS Message Center with Universal Gauge	Programmable Top Gear
Windshield Wiper and Washer	Vandalism Protection Locks
Center Mounted Rims (6) (44 × 63) (Used for 59/80R63 Tires)	Vital Information Management System (VIDS) w/Payload
Converter, 12V (2) Electrical	Monitor and MAX Payload and Speed Manager
Driveline Operator Safety Guard	
Electrical System, 24-volt 90 Amp at Low Idle	

Mandatory Equipment (with approximate changes in operating weight)

Mandatory and optional equipment may vary. Consult your Caterpillar dealer for specifics.

	kg	lb		kg	lb
Battery			Oil Cooler, Rear Axle	104	228
Standard	63	138	Pump, Standard	70	154
Heavy Duty	126	278	Seat		
Sealed	168	371	Cat Air Suspension, C500	0	0
Bumper			Isringhausen Air Suspension	0	0
Standard	1865	4112	Starting System, Air		
Towing	2135	4707	Vane Ingersoll	404	891
Exhaust			TDI Turbine	353	778
Side	61	133	Ingersoll Turbine	360	792
Rear through Body	321	706	Window		
Handrail Guard	30	65	Passenger Door, Fixed	0	0
Cover Guard	30	65	Passenger Door, Electric	0	0
Fuel Tank					
1000 Gallons	1406	3099			
1800 Gallons	2727	6012			

Optional Equipment (with approximate changes in operating weight)

	kg	lb		kg	lb
Body, Flat Floor	46 294	102,060	Oil Renewal System	15	32
Body Liner			Radiator Guard, Oil Sands	514	1132
Solid	3992	8800	Road Analysis Control (RAC)	6	13
Rock Box	1909	4210	Starting System, Cold Weather	94	207
Rear Grid	1769	3900	Tire Rim		
Engine Prelube, Air Start	3	7	Spare, 44-63, Standard	2940	6480
External Payload Display, Left, Right	46	100	Spare, 44-63, Wedge	2951	6504
Fire Extinguisher, Portable	21	45	Mounting Guard	71	156
Heater, Large Fuel Tank	18	39	Tires, 59/80R63 MX XDRC4** E4	31 815	70,140
High Altitude Modification	740	1630	Torque Converter Guard	269	591
Hose, Cab Cleanout	7	15	Wiggins Service Center	59	130

797B Mining Truck

For more complete information on Cat products, dealer services,
and industry solutions, visit us on the web at www.CAT.com

© 2003 Caterpillar
Printed in U.S.A.

AEHQ5511 (12-03)

Materials and specifications are subject to change without notice.
Featured machines in photos may include additional equipment.
See your Caterpillar dealer for available options.

CATERPILLAR[®]