

**ITC** INTERTECHNO TUNNELLING-EQUIPMENT COMMERCIAL SA

## TUNNEL DUMP TRUCK

# ITC 12000



- Tunnel articulated Dump Truck PAUS model ITC 12000 with all wheel drive and reverse seat
- Diesel drive 330 kW
- Pay load 25 t
- Operating weight 51 t

**EPAUS**  
*...the people who care*

# ITC 12000

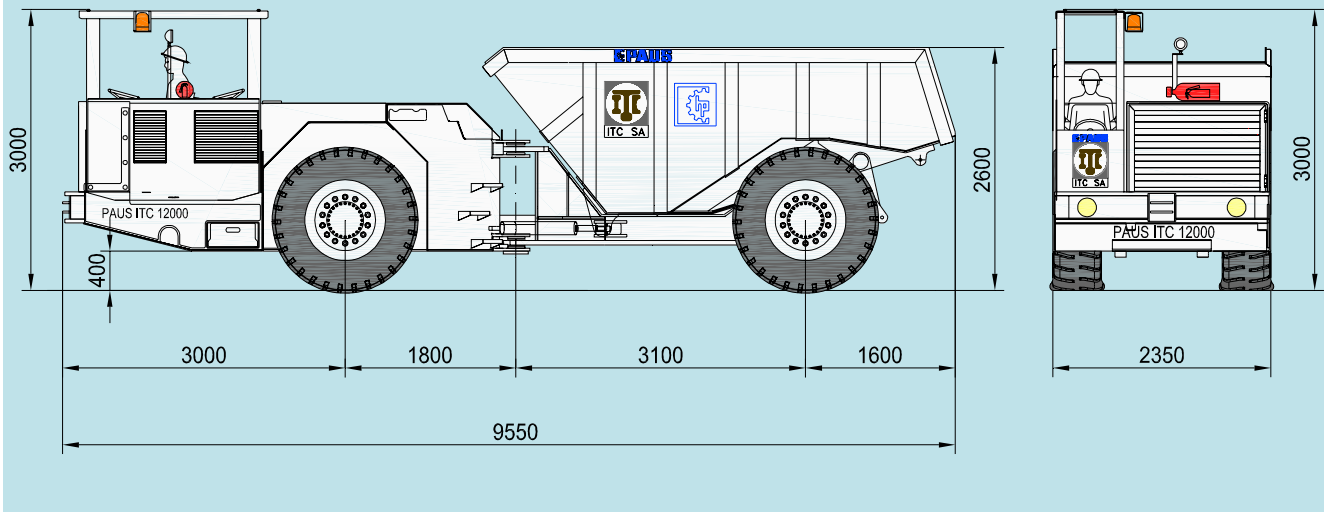

## Technical data ITC 12000

### Chassis

- Divided chassis with articulated joint and swinging front axle, articulated-joint lock, stable chassis frame welded out of high-quality sheet metal and sectional steel

### Engine

- Water cooled, turbocharged, intercooling DEUTZ Diesel engine TCD2015 V06, Dry filter with preliminary filter.
- Rated power : 330 kW at 2100 RPM
- Option:
  - Soot filter, Catconverter, water scrubber,...

### Electric system

- Electric system 24 V. Generator 28V, 80 A, battery 2 x 180 Ah, two headlights each front and rear, one working headlight

### Axles

- Kessler planetary rigid axles with enclosed multiple-disc brakes Rear axle fixed, front axle swingingly mounted to the vehicle frame, model D91.

### Drive line

- Industrial full powershift single stage torque converter
- 4-speed-change-on-the-move gear box, shiftable under load, with mechanic gearshift, all-wheel drive.
- front + rear single tired 18.00 R 25 E4-40PR.

### Travel speed

	forwards	backwards
1. Speed	4 km/h	4 km/h
2. Speed	9 km/h	9 km/h
3. Speed	17 km/h	17 km/h
4. Speed	25 km/h	25 km/h
climbing ability	30 %	30 %

### Brakes installation

- Hydraulic two-circuit pump storage brake system, with oil-immersed multiple-disc brakes enclosed in the axle box.
- Brake-pressure control by brake-circuit pressure gauge in driver's stand
- Hydraulic spring-loaded parking brake effective as slide-saddle brake at the axle input of the rear axle.

### Steering

- Central articulated joint with swinging front axle, pendulum angle +/- 8°,
  - steering angle +/- 40°, Two double-effective steering cylinders
  - Hydraulic caster-wheel steering, steering pump, steering orbital
  - emergency-steering features
- |                     |         |
|---------------------|---------|
| Inside turn radius  | 5330 mm |
| Outside turn radius | 8650 mm |

### Body Volume

- Rear-tipping skip,
- skip volume 12 m<sup>3</sup> struck, 14 m<sup>3</sup> heaped,
- two double-effective tipping cylinders

### Driver Stand

- Driver's stand with driver's shelter and roll-over bracket, the entry is secured by a chain, rear-view mirror
- Comfortable driver's seat with safety belt, hydraulically damped, adjustable, rotary driver's seat can be swiveled for 180° for two drivings
- Standard instruments, ammeter, automatic engine control for two driving directions easily accessible operating devices,
- The instruments and supervisory devices are installed in switch boxes
- signal in case of reverse movement
- two fire extinguishers

### Weight

empty weight:	26,0 to
perm. total weight:	51,0 to
payload:	25,0 to
axle load front:	20,5 to
axle load rear:	30,5 to

Further details of attachments and accessories available upon request.  
Subject to modification without prior notice.



Hermann Paus Maschinenfabrik GmbH  
[www.paus.de](http://www.paus.de) [mail@paus.de](mailto:mail@paus.de) ☎+49-5906 707 0



**ITC**  
 INTERTECHNO  
 TUNNELLING-EQUIPMENT  
 COMMERCIAL SA

ITC SA  
[www.itcsa.com](http://www.itcsa.com) [info@itcsa.com](mailto:info@itcsa.com) ☎+41 277 222 191