

Vehicle range

255

405

605

705

905



40 METRIC TONS



DUMP TRUCK DP 405



Manufacturers since 1957



Maximum payload: 40.000 kg

Capacity: 26 m³

40 Metric tons

40 Ton Standard vehicle

Maximum gross vehicle weight: 70.000 kg



DUMP TRUCKS - ALWAYS AT WORK

By this design concept, **Perlini** has developed a distinctive construction technique in its **Dump Trucks**, in order to make the job-site personell tasks of maintenance and repair during vehicle operation as easy as possible.

The components requiring maintenance, such as engine, transmission, differential, hydraulic pumps, suspensions and brakes, have been carefully designed and properly installed to minimize the truck downtime, thus improving availability, for a high productivity at low operational costs.



Performances

Gradeability performance

To calculate the maximum climb angle, please read from total weight at the bottom and follow the line upwards until it crosses the diagonal line matching the overall resistance percentage (where the "overall resistance" is the actual slope grade, with 1% added for every 10 kg/t of rolling resistance).

From this matching point of weight and resistance, move horizontally to the curve with the highest obtainable speed range, then down to the maximum speed.

Usable rim pull depends on traction available and weight on the drive wheels.

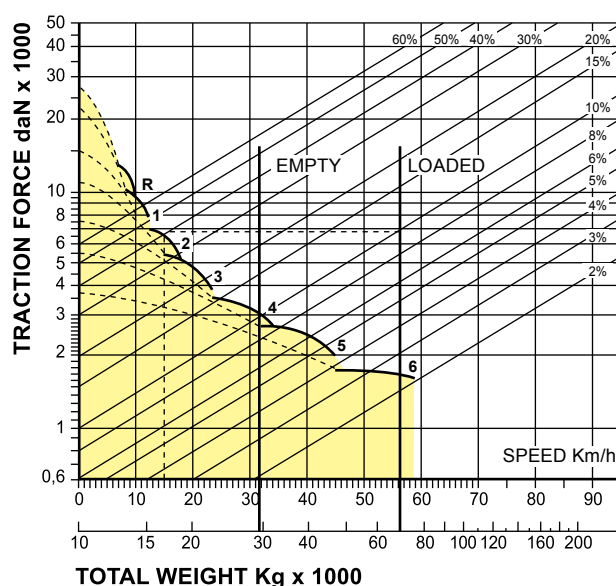

BETTER VEHICLE CONTROL = SAFETY

BRAKES

The main braking system consists of service brakes and of two retarder brakes.

The **service brakes** at the wheels are of disc dry type with single independent calipers equipped with wide and trick braking elements capable of developing the best braking transition in all operating conditions, especially on slippery terrain, thus assuring stability during operation.

The braking elements provided with great thickness and surface guarantee superior endurance, and can be easily replaced when changing tires, without disassembling the brake thrust elements, thus minimizing service time and costs.

The two **retarder brakes** (the engine brake and the hydraulic brake) have the advantage of a great reliability and long life, and have no wearing part.

The **engine brake**, acting on the engine exhaust valves, turns the engine into a compressor and produces a modulated braking power according to the engine current push.



It can develop a braking power of 380 HP at 2000 rpm. It is normally used to slow down the vehicle on flat terrains or downhill. It activates automatically when the accelerator pedal is released.

Traction control system ABS/ ASR

ABS

Anti-blocking system of the wheels while braking. It assures an excellent truck control while braking, even on low grip surfaces.

ASR

Traction control. Automatically activating in case of skidding of one or both the driving wheels, it guarantees truck stability even upward slopes with low grip sections.

WET MULTIPLE DISC BRAKES (optional)

Designed and manufactured by Perlini, they ensure reliable braking, especially on descending slopes and downhill tracks or slippery terrains. Featuring oversized discs to guarantee longer operational life.



LESS FUEL CONSUMPTION - LESS TIRE WEAR

The front oleopneumatic suspensions have been developed and produced with a particular fork design, for a reduced offset, allowing soft steering and reduced slipping of the tires on the ground.

This features convey better control and stability on the front wheels during straight motion, with comfortable and safe driving. This construction design allows easy inspection and replacement of seals, that can be performed without disassembling the suspension, but acting solely on its upper or lower chamber, with a significant reduction of service costs and truck downtime.

The lower pneumatic chamber is of large diameter, allowing low inside pressure and a longer seal life.

The rear oleopneumatic suspensions, of special Perlini design, provide an excellent flexibility to the truck in any conditions of application and loading. They are connected to the chassis and to the rear axle through ball joints, which allow a good oscillation amplitude, for better adjustment even on the roughest terrains. The wide axle base ensures best vehicle stability in turning and in winding haul roads. The large diameter of the pin reduces the inner pressure thus extending the life of the seals and, at the same time, giving a better flexibility. The inner shock-absorber dampens the vibrations transmitted through the rigid structure of the frame from the ground bumps. Perlini original suspensions allow, therefore, high cycle speeds with reduced stresses on the mechanical and structural components, greater productivity with high comfort.

Perlini suspensions, together with other general vehicle features, achieve the following advantages:

- Higher stability and driving comfort
- Higher average cycle speed
- Less tire wear
- Less fuel consumption
- Less stresses on the truck structural and mechanical components





MORE STABILITY - MORE SPEED - MORE CUBIC METERS HAULED

CAB

DP 405 cab is designed and manufactured to maximize the operator's comfort and safety, and complies with the EEC Standards. Optimum driving position, seat with double dampening, adjustable in height and depth, steering wheel adjustable in height and inclination, best accessibility of all controls with gear selector and body hoist control lever positioned on the dashboard next to the steering wheel. The visibility from the driving position is wide in all directions.

With air conditioner or heating system in operation, the noise level in the cab is: 79 dBA.

The instrument board is complete and assures a constant overview of the main vehicle functions.

DIMENSIONS at empty vehicle (mm)

All dimensions are approximate.

The length and width dimensions, the distance between the axles (wheel base) and the height of center of gravity of a vehicle are essential features assuring a best load distribution on wheels in every ground conditions, particularly on rough terrain, as well as on uphill and downhill tracks.

In the DP 405 the optimum weight distribution, obtained through the large wheel base and width, as well as to the low centre of gravity, improves vehicle performances, allows better turning control with safer and easier drive, improves adherence, reduces fuel consumption and tire wear, and contributes to higher average cycle speed and, in the end, to a greater productivity.

External noise level in conformity with the directive 2000/14/EEC

Dimensions at empty vehicle (mm) - All dimensions are approximate

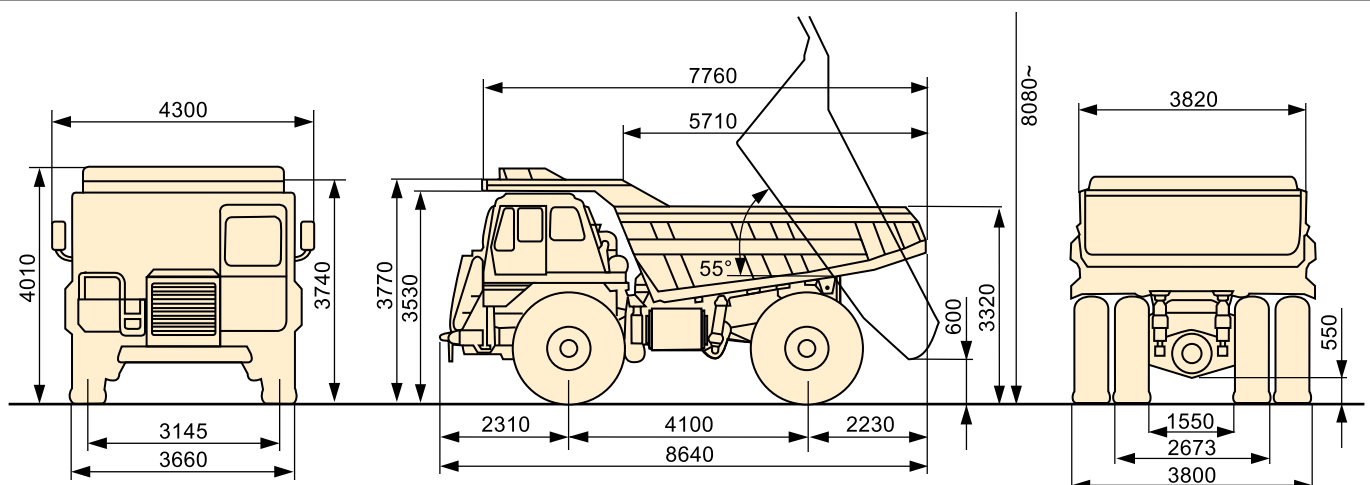

Specifications, weights, dimensions and tolerance can be changed at any time without previous notice.

This vehicle complies with the ECC safety standards - Standard 2006/42.

DP 405 SPECIFICATIONS

Maximum payload: 40.000 kg ● Capacity: 26 m³

ENGINE *

*Engine emissions meet 97/68 EC stage III regulations

| | |
|-----------------------|--|
| Model | Detroit Diesel S 60 |
| Type | 4 cycle water cooled |
| Air system | Turbocharged with intercooler |
| N° of cylinders | 6 in line |
| Bore x stroke | 133 x 168 mm |
| Displacement | 14.00 lt |
| Gross power SAE J1995 | 410 Kw (550 HP) at 2100 rpm |
| Max Torque | 2373 Nm at 1350 rpm |
| Filter | Dry type, heavy duty, double elements, precleaner and dust indicator |
| Control | Electronic DDEC V system |

DRIVE AXLE

Perlini heavy duty with single central reduction and built-in differential, full floating axle shafts and four-planetaries epicyclic train at the wheels.

| | |
|---------------------|-----------|
| Central reduction | 3.06 : 1 |
| Epicyclic reduction | 5.25 : 1 |
| Total reduction | 16.06 : 1 |

FRAME

Box sectioned longitudinal members made of high yield strength steel plate, connected to each other by means of tubular cross members with special torsion proof joints.

SUSPENSIONS

Front - Original Perlini fork type, independent, oil pneumatic with built-in shock absorbers.

Stroke 245 mm

Rear - Original Perlini type, oil pneumatic with built-in shock absorbers.

Stroke 250 mm

BODY

Structure.....Ribwork structured body with dual slope and flat bottom

Material High tensile strength steel (1250 N/mm²)

Average hardness 400 HB

Body canopy.....**ROPS/FOPS ISO 3471 and ISO 3449**

Thickness (standard body)

Bottom 20 mm

Front 12 mm

Side 10 mm

Capacities standard body

Struck 19,5 m³

Heaped SAE 2:1 26,0 m³

DUMPING SYSTEM

Rear dumping by means of twin hoist cylinder, 2 stages, telescopic double acting, mounted outside the frame.

Hydraulic pump flow..... 270 litres/min

Max. pressure 150 bar

Insertion Only during the unloading phase

Dumping time 12 sec

Dumping angle 55°

ELECTRICAL SYSTEM

Tension 24 V

Batteries n° 2 batteries, 180 Ah each

Alternator 24 V - 75 A

TRANSMISSION

Full automatic, planetary gear, multidisc clutches hydraulically activated.

Model Allison H 5610

Torque converter 3 elements TC 682

Lock-up clutch Automatically inserted-effective in all forward ranges

Mounting Remote type

Shift control Automated - controlled electronically

Gears 6 speeds forward and two reverse

Retarder (optional) Coupling type rotor between fixed stators

Gear 1 2 3 4 5 6 R1 R2

Ratio 4,00 2,68 2,01 1,35 1,00 0,67 5,12 3,46

STEERING - ISO 5010

Independent hydraulic system with twin double-acting cylinders.

An electric pump inserted into the hydraulic circuit allows steering in case of power source failure.

Main pump flow 200 litres/min

Max. pressure 130 bar

Turning radius 8.9 m

TIRES

Singly mounted at front and dually at rear, with interchangeable rims.

Type Radial E4

Standard tire size 18.00 x 33"

Standard rim size 13.00 x 33"

BRAKES - ISO 3450

Service

Front - Selfadjusting disc type, air-over-oil actuated with a separate circuit.

Disc dimension 675 x 48 mm

Rear - Sealed multiple disc brakes, cooled by oil forced circulation.

Brake surface (rear axle) 55.150 cm²

Retarder rear brakes - Air-over-oil, controlled by a lever inside the cab positioned on the steering column.

Standing braking power 746 kW (1000 HP)

Parking - Disc type, spring applied, pneumatic released actuates on drive shaft.

Disc diameter 438 mm

Emergency - Due to the two separate circuits, braking is assured even in case of failure of one circuit.

Engine brake - The engine brake converts a power producing diesel engine into a power absorbing air compressor. The function is by electric control.

Braking power 283 kW (380 HP) at 2100 rpm

Alternatively:

Service brakes (front and rear) - Selfadjusting disc type, air-over-oil actuated with two separate circuits.

Retarder - Hydraulic coupling type rotor between fixed stators.

Actuated by a cab pedal. It acts automatically in case of engine overspeed.

Braking power 447 kW (600 HP) at 2100 rpm

PERFORMANCES

| | | | | | | | | |
|-------|------|------|------|------|------|------|-----|------|
| Gear | 1 | 2 | 3 | 4 | 5 | 6 | R1 | R2 |
| Speed | 10,5 | 15,7 | 21,0 | 31,3 | 42,3 | 63,1 | 8,2 | 12,2 |



STANDARD EQUIPMENT

- Electric starting engine.
- Electronic powershift transmission.
- Jacobs engine brake.
- Interchangeable front disc brakes.
- Wet multiple-disc rear brakes and retarder.
- Body heating by means of exhaust smokes.
- Parking disc brake.
- Manoeuvre brake system.
- Power steering system with electric emergency pump.
- Dry air filters with clogging indicators.
- Headlights with dimmer switch.
- Directional signals, stop and tail lights.
- Back up lights and alarm.
- Automatic air-conditioning system.
- Traction control system ABS/ASR.
- Automatic central lubricating system.
- Type-tested windshield with washer and wiper.
- Rock ejectors and towing hook.
- Locking system for lifted body.
- Insulated and sound proofed cab.
- Cushioned and adjustable operator's seat.
- Adjustable steering wheel.
- Ashtray.
- Air dryer on pneumatic system.
- Alternator 75 A.
- E4 Radial tires.
- Right and left rear-view mirrors.

OPTIONAL EQUIPMENT

- Heavy duty body (bottom 25 mm, side 12 mm, front 15 mm).
- Spring engaged, engine fan drive.
- Interchangeable rear disc brakes
- Hydraulic retarder.
- Engine pre-heating system.
- Xenon lights.
- Fuel filter with water separator.
- Platform for cab access, left side.
- Front and side body canopy protection.
- Rear view mirrors, heated.
- Monitor in cab for rear view.
- On board weighting system.
- Tachograph.
- AM/FM radio with cd player.

CAB

Two doors design, with controls arrangement and driver's space conforming with EEC standard. It rests flexibly on the frame by means of special rubber elements. Heat insulated and sound proofed, it is equipped with a comfortable weight-adjusting operator's seat, adjustable steering wheel and a complete and easy readable dash panel. Automatic air-conditioning system.

SERVICE CAPACITIES (litres)

| | |
|-------------------------------------|-----|
| Engine oil | 40 |
| Allison transmission oil | 58 |
| Drive axle oil | 110 |
| Brakes and dumping system oil | 250 |
| Steering system oil | 32 |
| Suspensions oil (total) | 44 |
| Cooling system | 115 |
| Fuel tank | 500 |

MASSES *

** approximate values*

| | |
|---|-----------|
| Empty weight (with standard body) | 29.800 kg |
| Payload | 40.000 kg |
| Gross vehicle weight | 69.800 kg |

| Weight distribution | Loaded | Empty |
|---------------------|--------|-------|
| Front | 33% | 48% |
| Rear | 67% | 52% |



40 metric tons



Perlini Equipment S.p.a.
Via Villanova, 75 - S.R.11 - I - 37047 San Bonifacio (VR)
Tel. +39 045 7611333 - Fax: +39 045 7612221
sales@perlini.com - www.perlini.com

