



DPT 70

70 METRIC TONS



PERLINI[®]
Equipment
veicoli • dumpers • meccanica industriale

Manufacturers since 1957

Perlino Equipment S.p.A.
Via Villanova 75 - S.R. 11 - I-37047 San Bonifacio (VR)
Tel. +39 045 7611333 Fax +39 045 7612221
sales@perlino.com - www.perlino.com



ENGINE

Model.....Detroit Diesel S.60
 Type.....4 cycle – water cooled
 Air system.....Turbocharged with intercooler
 N° of cylinders.....6 in line
 Bore x stroke.....133 x 168 mm
 Displacement.....14 litres
 Gross power SAE J1995.....410 Kw (550 HP) at 2100 rpm
 Max torque.....2373 Nm at 1350 rpm
 Air filter.....Dry type with double elements, precleaner and dust indicator
 Control.....Electronic - DDEC V system
 Engine emissions meet 97/68 EC stage III regulations

TRANSMISSION

Full automatic, planetary gear, multi-disc clutches hydraulically activated
 Type.....Allison H 6610
 Torque converter.....3 elements TC 682
 Lock-up clutch.....Automatically intersted, effective in all forward ranges
 Range.....6 speeds forward, 2 reverse

Gear	1	2	3	4	5	6	R1	R2
Ratio	4,00	2,68	2,01	1,35	1,00	0,67	5,12	3,46
Speed	10,5	15,7	21,0	31,3	42,3	55,0	8,2	12,2

DRIVE AXLE

Perlini heavy duty with single central reduction and built-in differential, full floating axle shafts and four-planetaries epicyclic train at the wheels.
 Central reduction.....3,06 : 1
 Epicyclic reduction.....5,25 : 1
 Total reduction.....16,06 : 1

TRAILER AXLE

Perlini heavy duty.
 The wheel hubs, bearings, rims fixing and braking system are all the same as the second drive axle.

SUSPENSIONS

Front: Original Perlini fork-type, independent, oil pneumatic with buit-in shock absorbers
 Stroke.....245 mm
Rear (drive axle and trailer axle): Original Perlini, oil pneumatic with buit-in shock absorbers
 Stroke (drive axle).....250 mm
 Stroke (trailer axle).....270 mm

STEERING – ISO 5010

Independent hydraulic system with twin double-acting cylinders. An electric pump inserted into the circuit allows steering in case power failure.
 Main pump flow.....200 litres/min
 Max. pressure.....130 bar

BRAKES

Service

1st axle – Self-adjusting dry disc type.
2nd axle – Oil wet brakes cooled by forced oil circulation.
3rd axle – Oil wet brakes with forced oil circulation and sensor alarm

Parking: Disc type, spring applied, pneumatic release, actuates on the power train on the input flange of the drive axle.
 Disc dimension.....438 x 44 mm

Emergency: With 3 separate circuits, braking is assured even in case of failure of one or two circuits

Retarder: Acts with the insertion of the oil wet brakes.

Engine brake: The Jacobs engine brake acts on the engine valves, making the engine function as a compressor.
 Braking power.....283 kW (380 HP) at 2000 rpm

TIRES

Singly mounted at front and dually on the drive axle and the trailer, the rims are interchangeable.
 Standard tire size.....18 R 33"
 Rim size.....13,00 x 33"

DUMPING SYSTEM

Lateral dumping with mechanic tailgate, automatically opening with chain or cable.
 Independent hydraulic circuit with PTO.
 Max dumping angle.....50°

BODIES (2)

High resistance steel coating, with proper reinforcing cross members on the bottom, front and side.
 Bottom thickness.....12 mm
 Side thickness.....8 mm
 Front thickness.....8 mm
 Body capacity.....23 m³ each

MASSES

Empty weight with light body.....45.000 kg
 Max. payload.....70.000 kg
 Total max weight.....115.000 kg

Weight distribution (loaded truck)	1 st axle	20%
	2 nd axle	40%
	3 rd axle	40%

FRAME

Tractor: Box sectioned members made of high yield strength steel plate, connected to each other by means of tubular cross members with special torsion-proof joints.

Trailer: Heavy duty frame with box section of high strength steel plate. The two side-members are connected through tubular cross members soldered by special reinforcing rings.

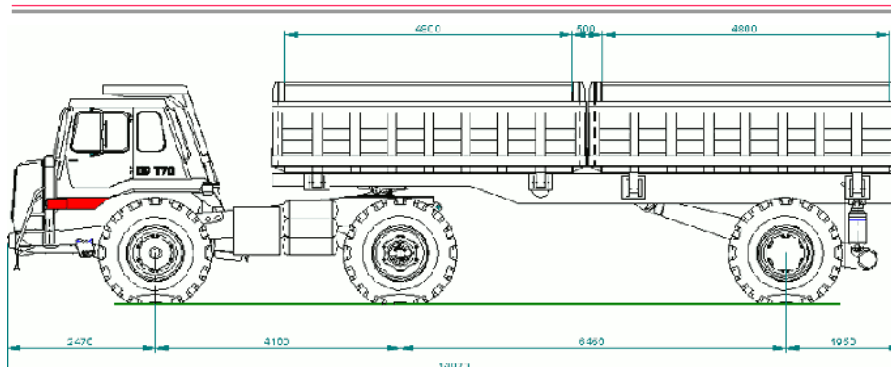

Dimensions at empty vehicle (mm).

All dimensions are approximate.

This vehicle complies with ECC 2006/42 safety standards.

Specifications, weights and dimensions can be changed at any time without previous notice.

DPT 70: a truck like no other

- Halfway between a rigid and an articulate hauler, the DPT 70 is capable of carrying 70 tons of material - **more than any articulated truck** currently in production.
- It's capable of performing **many different tasks** by equipping **different trailers**. Trailers can be switched, and the same machine can perform different work and adapt to changing needs, just by replacing the trailer.
- Features **three separate braking systems** for added reliability. Drive axle and trailer feature the extra-secure Perlini original **oil wet brakes**, powerful, with an incorporated retarder and requiring almost no maintenance due to the forced oil circulation cooling system.



Perlini: the power of technology

With **over fifty years of excellence in manufacturing**, Perlini is the brand of choice for everyone, from big enterprises to small subcontractors, who cares about getting the job done.

Quality fitting a multinational company, customer care and simplicity of a family business, there are many reasons to choose Perlini products.



Perlini dump-trucks are designed for maximum efficiency: **fuel consumption is 10% inferior (on average)**, due to the quality of Perlini components and the design structure with a low center of gravity, smooth suspensions and long distance between the axles.



No dumper on the market is as **easy to maintain** as a Perlini.

- All drive train components are independent and can be individually replaced. The differential can be detached from the rear.
- Separated installation of engine and transmission.
- Suspension seals and brake pads can be easily and quickly replaced without working on suspensions or braking system.



High quality of **Perlini manufactured components**.

- Lower fuel consumption and tire wear, higher stability through the suspensions wider oscillation and larger axle base.
- Security with independent braking systems, improved performance and efficiency with the new oil cooled multiple disc brakes.
- The frame is designed for optimum weight distribution.



If you have special needs, Perlini can provide a **truck meeting your requirements**. Should you need a customized body for specific material, or a specialized structure for a difficult haul track, **a customized Perlini truck will give you what you can't get from any range vehicle**.

The vast majority of trucks exiting Perlini factories are specialized.

One truck, many uses

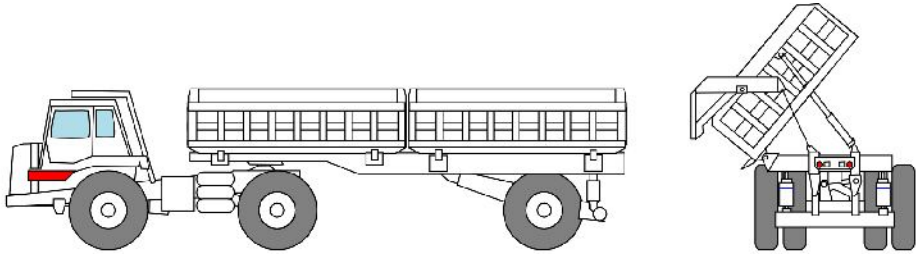

Side tipping, dual body

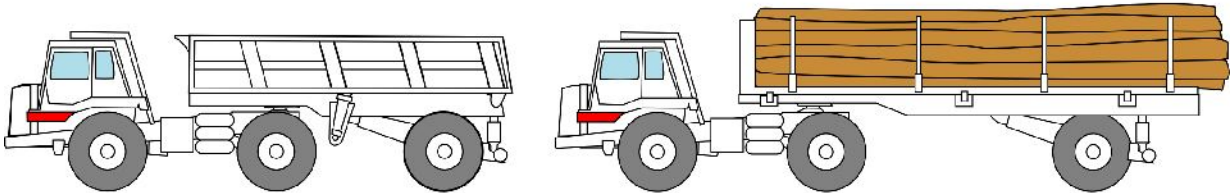

Rear tipping

Specialized wood body

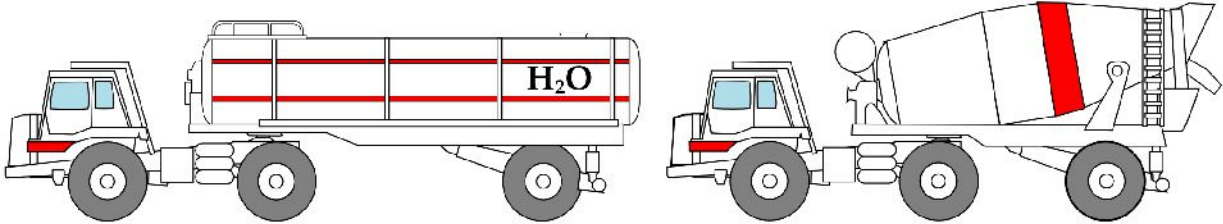

Tank

Cement mixer

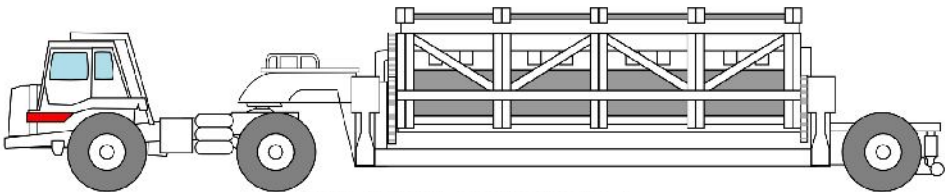

Container hauler

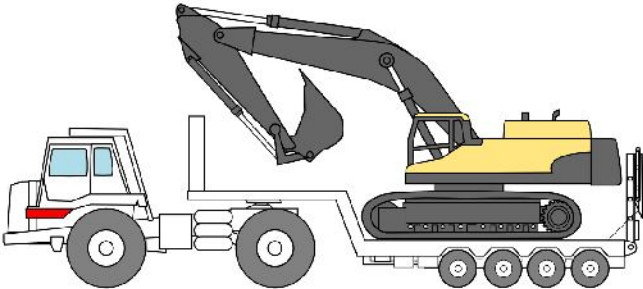

Exceptional transport