

32 t
RC30



SPECIFICHE TECNICHE

PRESTAZIONI DELLA GRU

Portata a 3 m da asse ralla (CE)	32 t
Lunghezza braccio (chiuso / aperto)	9.1 / 24.1 m
Altezza testa braccio	27 m

PRESTAZIONI DEL CARRO ⁽¹⁾

Velocità massima di traslazione (con pneumatici 14.00R24)	30 km/h
Velocità massima di traslazione (con pneumatici 16.00R25)	31 km/h
Rampa massima teorica in condizioni di marcia (con pneumatici 14.00R24)	98 %
Rampa massima teorica in condizioni di marcia (con pneumatici 16.00R25)	84 %

(1) Gru in versione standard ed in condizioni di marcia: senza argano ausiliario, senza prolunghe

MASSE ⁽²⁾

I° assale	II° assale	Totale
10.7 t	12.8 t	23.5 t

(2) Gru in versione standard: senza argano ausiliario, senza prolunghe, con pneumatici 16.00R25

VELOCITÀ / TEMPI DI LAVORO ⁽³⁾

Argano (massima in tiro diretto)	80 m/min
Sollevamento / Discesa braccio telescopico	77 / 67 s
Sfilo / Rientro braccio telescopico (da 9.1 m a 24.1 m)	92 / 40 s
Rotazione sovrastruttura	25 s
Sfilo singola traversa porta-stabilizzatori	4 s
Sfilo completo singolo stabilizzatore	10 s

(3) Valori medi di riferimento forniti a puro titolo indicativo

CARRO

Trazione/Sterzo	4x4x4
Telaio	A doppio longherone a cassone. Punto di traino anteriore (in opzione anche posteriore)
Stabilizzatori	n. 4 idraulici indipendenti installati su travi sfilabili idraulicamente. Stabilizzazione con travi rientrate, parzialmente o completamente estese. Azionamento dalla cabina di guida
Motore	CUMMINS QSB 4.5 : 4 cilindri in linea elettronico - cilindrata 4.5 dm ³ - Turbocompresso. Potenza massima 104 kW a 2000 giri/min - Coppia massima 504 Nm a 1800 giri/min. Certificazione 2004/26/CE Fase IIIA
Serbatoio	240 l
Trasmissione	DANA serie 20000: Tipo powershift con convertitore di coppia. 3+3 marce avanti e 3+3 retromarce con selezione di gamma lenta e veloce. Inserimento automatico della trazione integrale selezionando la gamma lenta
Freni	Servizio: a doppio circuito a tamburo su tutte le ruote ad azionamento idropneumatico. Stazionamento / Emergenza: negativo sull'albero di trasmissione anteriore del tipo a molla con azionamento pneumatico
Assali	n. 2 assali motori e sterzanti con riduttori epicicloidali nei mozzi. In opzione possibilità di blocco dei differenziali
Sospensioni	Rigida su assale anteriore, oscillazione dell'assale posteriore. Blocco automatico dell'oscillazione posteriore mediante martinetti idraulici quando il braccio di sollevamento non è nel settore anteriore della gru allineato sull'asse di mezzzeria. Possibilità di blocco manuale dalla cabina dell'oscillazione posteriore.
Sterzo	Idrostatico mediante volante in cabina di guida. Possibilità di sterzata del solo assale anteriore o di entrambi in modalità concentrica o a granchio.
Pneumatici	n. 4 pneumatici 14.00R24. In opzione n. 4 pneumatici 16.00R25 (16.00-25) tubeless

SOVRASTRUTTURA

Braccio	n. 3 elementi a sezione ottagonale
Sollevamento	n. 1 martinetto idraulico a doppio effetto. Possibilità di inclinazione del braccio da -2° a $+78^{\circ}$
Sfilo	Gli elementi 2 e 3 sono sfilati in modo proporzionale e continuo mediante un martinetto idraulico a doppio effetto ed un sistema interno di rinvio a catene. Possibilità di sfilo sotto carico parziale.
Argano	Azionato da motore idraulico a pistoni assiali a cilindrata fissa con riduttore epicicloidale. Freno negativo ad inserimento automatico. Dispositivo pressafune. Doppia velocità di rotazione. Fune diametro 15 mm, lunghezza 140 m. (capacità massima di sollevamento 3800 daN). In opzione argano ausiliario avente le medesime caratteristiche di quello principale. Fune diametro 15 mm.
Rotazione	Continua su 360° mediante motore idraulico e riduttore epicicloidale su ralla a doppio giro di sfere con dentatura interna. Freno negativo ad inserimento automatico. Comando di sblocco del freno per l'allineamento diretto del braccio sulla verticale del carico da sollevare
Cabina	Ad ampia visibilità con sportello scorrevole. Dotata di riscaldamento. Vetro anteriore e superiore con tergicristallo. Vetro superiore e posteriore apribili. Seggiolino completamente regolabile su sospensioni anti-shock, dotato di braccioli sollevabili che integrano i manipolatori per il comando dei vari movimenti della gru.
Sicurezza	Valvole di blocco sui martinetti di sfilo e sollevamento braccio e sugli stabilizzatori. Valvole di massima pressione su ogni circuito idraulico. Valvola di bilanciamento e frenatura su gruppo rotazione. Valvola di bilanciamento e frenatura sull'argano. Interruttore di fine corsa su testa braccio per la salita del bozzello. Interruttore di fine corsa per conservare tre giri di avvolgimento fune sull'argano. Dispositivo limitatore di carico con indicazione: <ul style="list-style-type: none">Inclinazione braccioLunghezza braccioCarico sollevatoMassimo carico sollevabile

IMPIANTI

Idraulico	Alimentazione: n. 2 pompe doppie ad ingranaggi. Controllo movimenti: distributori azionati da manipolatori idraulici con possibilità di manovre simultanee proporzionali. Controllo stabilizzatori: elettrovalvole azionate da pulsanti indipendenti. Filtraggio: n. 1 filtro a cartuccia sul circuito di ritorno. Scambiatore di calore per il raffreddamento dell'olio
Elettrico	a 24 V con alternatore da 70 A e n. 2 batterie da 132 Ah. Dispositivi di illuminazione conformi alle direttive dell'Unione Europea
Pneumatico	Compressore da 250 cm ³ , n. 2 serbatoi da 45 l ciascuno e dispositivo essiccatore. Presa d'aria ausiliaria e kit di gonfiaggio pneumatici

OPZIONALI

Prolunga tralicciata da 0.7 + 7.3 m

Impianto condizionatore caldo/freddo in cabina guida

Kit avviamento motore basse temperature

Argano ausiliario

Bozzello da 10 T

Gancio da 5 T

Riferirsi al dealer di zona per un elenco completo degli opzionali.

SPECIFICATIONS

CRANE PERFORMANCE DATA

Capacity at 3 m from slewing ring axis (CE)	32 t
Boom length (retracted / extended)	9.1 / 24.1 m
Boom head height	27 m

TRUCK PERFORMANCE DATA ⁽¹⁾

Max. theoretical travelling speed (on 14.00R24 tyres)	30 km/h
Max. theoretical travelling speed (on 16.00R25 tyres)	31 km/h
Max. theoretical ramp during operation (on 14.00R24 tyres)	98 %
Max. theoretical ramp during operation (on 16.00R25 tyres)	84 %

(1) Standard crane in operating conditions: no auxiliary winch and no extensions

WEIGHTS ⁽²⁾

1 st axle	2 nd axle	Total
10.7 t	12.8 t	23.5 t

(2) Standard crane: no auxiliary winch and no extensions, on 14.00R24 tyres

OPERATING SPEED / TIMES ⁽³⁾

Main winch (max. speed under direct pull)	80 m/min
Telescopic boom lifting / lowering	77 / 67 s
Telescopic boom extension / retraction (9.1 m to 24.1 m)	92 / 40 s
Upper structure slewing	25 s
Extension of single outrigger beam	4 s
Extension of single outrigger	10 s

(3) Average reference indicative values

TRUCK

Traction/Steering	4x4x4
Frame	With twin body side member. Front tow point (back tow point on request)
Outriggers	no. 4 independent hydraulic outriggers onto hydraulic beams. Outrigger beams can be fully retracted, partially or fully extended. Outrigger controls in the operating cab.
Engine	CUMMINS QSB 4.5 : no. 4 in-line cylinders - displacement 4.5 cu dm - Turbocharged - Intercooler - Common rail. Max. power 104 kW at 2000 rpm - Max. torque 504 Nm at 1800 rpm. 2004/26/CE Step IIIA approved
Tank	240 l
Transmission	DANA series 20000: Powershift-type transmission with torque converter. 3 + 3 forward speeds and 3 + 3 reverse speed: slow and fast speed mode. Automatic engagement of 4WD after selecting slow speed mode
Brakes	Operating brakes: double-circuit hydro-pneumatic drum brakes on all wheels. Parking / Emergency brake: negative action onto front transmission shaft. Pneumatic spring brake.
Axles	no. 2 driving / steering axles equipped with planetary gearboxes into hubs. On request, differential locks
Suspension	Stiff suspension for front axle, swinging suspension for rear axle. Rear suspension is automatically locked by hydraulic jacks if lifting boom is not aligned with centreline within front crane area. Manual stop for rear suspension locking in operating cab.
Steering	Hydrostatic steering controlled by steering wheel into the operating cab. Steering of front axle alone or both axles in concentric or crab mode.
Tyres	no. 4 14.00R24 tubeless tyres On request, no. 4 16.00R25 (16.00-25) tubeless tyres

UPPER STRUCTURE

Boom	no. 3 octagonal elements
Lifting	no. 1 double action hydraulic jack - Boom inclination: -2° to +78°
Extension	Continuous proportional extension of elements 2 and 3 through double action hydraulic jack and inner chain-driven system. Extension under partial load possible.
Winch	Controlled by fixed displacement hydraulic motor equipped with axial pistons and planetary gearbox. Automatic negative brake for winch lowering. Cable tensioner. Two different rotation speeds. Rope diameter 15 mm length 140 m. Max. lifting capacity 3800 daN On request, auxiliary winch featuring same specifications as main winch. Rope diameter 15 mm.
Slewing	360° non-stop rotation controlled by hydraulic motor equipped with planetary gearbox on slewing ring having double ball ring and inner toothing. Automatic negative brake. Brake release for direct alignment of boom along load vertical line.
Operating cab	Sliding door. Wide visibility. Equipped with heating system. Front and upper window with windscreen wiper. Upper and back windows can be opened. Fully adjustable seat onto shockproof suspensions. Equipped with tiltable arm rests with integrated hand controls for crane operation.
Safety	Stop valves onto extension / lifting boom jacks and outriggers. Max. pressure valves for each hydraulic circuit. Balancing braking valve for the slewing unit. Balancing braking valve for the winch. Limit switch onto boom head for hoisting block lift. Limit switch for having three winding turns around the winch. Load limiting device with indicator for: <ul style="list-style-type: none"> Boom inclination Boom length Load weight Max. load which can be lifted

SYSTEMS

Hydraulic system	Feeding: no. 2 double gear pumps. Movement control: distributors controlled by hydraulic hand controls. More proportional operations can be carried out at the same time. Outrigger control: solenoid valves controlled by separate buttons. Filtering: no. 1 cartridge filter in return circuit Heat exchanger for oil cooling-down
Electric system	24 V, 70 A generator and no. 2 132 Ah batteries Lighting devices in compliance with current EU directives.
Pneumatic system	250 cu cm compressor, no. 2 45 l reservoirs and drier Auxiliary air intake and tyre inflating kit

MAIN OPTIONS

Lattice extension 0.7 m + 7.3 m long

Air conditioning / heating system into operating cab

Cold engine starting kit

Auxiliary winch

10 t hook block

5 t hook

Refer to your local dealer for a complete list of available options.

CARACTÉRISTIQUES

PERFORMANCES DE LA GRUE

Portée à 3 m de l'axe de crapaudine (CE)	32 t
Longueur flèche (rentrée/sortie)	9.1 / 24.1 m
Hauteur tête de flèche	27 m

PERFORMANCES DU CHARIOT ⁽¹⁾

Vitesse maximum de translation (avec pneumatiques 14.00R24)	30 km/h
Vitesse maximum de translation (avec pneumatiques 16.00R25)	31 km/h
Rampe maximum théorique en conditions de marche (avec pneumatiques 14.00R24)	98 %
Rampe maximum théorique en conditions de marche (avec pneumatiques 16.00R25)	84 %

(1) Grue en version standard et en conditions de marche: sans treuil auxiliaire, sans rallonge

MASSE ⁽²⁾

I° essieu	II° essieu	Total
10.7	12.8	23.5 t

(2) Grue en version standard: sans treuil auxiliaire, sans rallonge, avec pneumatiques 14.00R24

VITESSE / TEMPS DE TRAVAIL ⁽³⁾

Treuil (maximum en tirage direct)	80 m/min
Relevage / Descente flèche télescopique	77 / 67 s
Sortie / Rentrée flèche télescopique (de 9.1 m à 24.1 m)	92 / 40 s
Rotation superstructure	25 s
Sortie single traverse porte-stabilisateurs	4 s
Sortie complète single stabilisateur	10 s

(3) Valeurs moyennes de référence à titre purement indicatif

CHÂSIS

Traction/Braquage	4x4x4
Châssis	A double longeron à caisson. Point de remorquage antérieur (en option AR également)
Stabilisateurs	n. 4 hydrauliques indépendants installés sur barres à sortie hydraulique. Stabilisation avec barres rentrées, partiellement ou totalement sorties. Actionnement à partir de l'habitacle
Moteur	CUMMINS QSB 4.5 : 4 cylindres en ligne électronique - cylindrée 4.5 dm ³ - Turbocompressé. Puissance maxi 104 kW à 2000 t/min - Couple maxi 504 Nm à 1800 t/min. Certification 2004/26/CE Phase IIIA
Réservoir	240 l
Transmission	DANA série 20000: Type powershift avec convertisseur de couple. 3+3 marches avant et 3+3 AR avec sélection de gamme lente et rapide. Enclenchement automatique de la traction intégrale en sélectionnant la gamme lente
Freins	Service: à double circuit à tambour sur toutes les roues à actionnement hydropneumatique. Stationnement / Urgence: négatif sur l'arbre de transmission AV du type à ressort avec actionnement pneumatique
Essieux	n. 2 essieux moteurs et directionnels avec réducteur épicycloïdal sur les moyeux. En option possibilité de blocage des différentiels
Suspension	Rigide sur essieu AV, oscillation de l'essieu AR. Blocage automatique de l'oscillation AR par vérins hydrauliques quand le bras de levage ne se trouve pas dans le secteur AV de la grue aligné sur l'axe médian. Possibilité de blocage manuel à partir de la cabine de l'oscillation AR.
Braquage	Hydrostatique par volant dans la cabine de conduite. Possibilité de braquage de l'essieu AV ou des deux en mode concentrique ou en crabe.
Pneumatiques	n. 4 pneumatiques 14.00R24. En option n. 4 pneumatiques 16.00R25 (16.00-25) tubeless

SUPERSTRUCTURE

Flèche	n. 3 éléments à section octogonale
Relevage	n. 1 vérin hydraulique double effet. Possibilité d'inclinaison de la flèche de -2° à $+78^{\circ}$
Sortie	Les éléments 2 et 3 sont sortis de façon proportionnelle et continue par un vérin hydraulique double effet et un dispositif interne de renvoi par chaînes. Possibilité de sortie sous charge partielle.
Treuil	Actionné par moteur hydraulique à pistons axiaux à cylindrée fixe et réducteur épicycloïdal. Frein négatif à enclenchement automatique. Dispositif serre-câble. Double vitesse de rotation. Câble diamètre 15 mm longueur 140 m. Capacité maximum de levage 3800 daN. En option treuil auxiliaire possédant les mêmes caractéristiques que le treuil principal. Câble diamètre 15 mm.
Rotation	Continue sur 360° par moteur hydraulique et réducteur épicycloïdal sur crapaudine double tour de sphères avec denture interne. Frein négatif à enclenchement automatique. Commande de déblocage du frein pour l'alignement direct de la flèche sur la verticale de la charge à soulever.
Cabine	A ample visibilité avec porte coulissante. Dotée de chauffage. Vitre AV et supérieure avec essuie-glace. Vitre AR et supérieure ouvrante. Siège complètement réglable sur suspensions antichoc, avec accoudoirs relevables contenant les manettes de commandes des mouvements de la grue.
Sécurité	Soupapes de blocage sur les vérins de sortie et de relevage de flèche et sur les stabilisateurs. Soupapes de pression maxi sur chaque circuit hydraulique. Soupape d'équilibrage et de freinage sur groupe de rotation. Soupape d'équilibrage et de freinage sur treuil. Interrupteur de fin de course sur tête de flèche pour montée du moufle. Interrupteur de fin de course pour conserver trois tours d'enroulement de câble sur le treuil. Dispositif limiteur de charge avec indication: Inclinaison flèche Longueur flèche Charge soulevée Charge maximum soulevable

INSTALLATIONS

Hydraulique	Alimentation: n. 2 pompes double à engrenages. Contrôle de mouvements: distributeurs actionnés par manipulateurs hydrauliques avec possibilité de manoeuvres simultanées proportionnelles. Contrôle stabilisateurs: électrosoupapes actionnés par boutons indépendants. Filtrage: n. 1 filtre à cartouche sur le circuit de retour. Echangeur de chaleur pour le refroidissement de l'huile
Electrique	24 V avec alternateur de 70 A et n. 2 batteries 132 Ah. Dispositifs d'éclairage conformes aux directives de l'Union Européenne
Pneumatique	Compresseur de 250 cm ³ , n. 2 réservoirs de 45 l chacun et dispositif déshumidificateur. Prise d'air auxiliaire et kit de gonflage des pneumatiques

OPTIONS PRINCIPALES

Extension treillis de 0.7 + 7.3 m

Groupe de climatisation chaud / froid dans la cabine de conduite

Kit démarrage à froid moteur

Treuil auxiliaire

10 t moufle

Crochet 5 t

Se référer au concessionnaire local pour une liste complète des options.

TECHNISCHE DATEN

LEISTUNGEN DES KRANS

Tragfähigkeit bei 3 m ab Drehkranzachse (EG)	32 t
Länge Teleskopausleger (ein-/ausgefahren)	9.1 / 24.1 m
Höhe Auslegerkopf	27 m

LEISTUNGEN DES WAGENS ⁽¹⁾

Max. Fahrgeschwindigkeit (mit Bereifung 14.00R24)	30 km/h
Max. Fahrgeschwindigkeit (mit Bereifung 16.00R25)	31 km/h
Max. theoretische Steigung bei Fahrt (mit Bereifung 14.00R24)	98 %
Max. theoretische Steigung bei Fahrt (mit Bereifung 16.00R25)	84 %

(1)Kran in Standardausführung bei Fahrbetrieb: ohne Hilfswinde, ohne Verlängerungen

MASSE ⁽²⁾

1. Achse 10.7	2. Achse 12.8	Gesamtgewicht 23.5 t
-------------------------	-------------------------	--------------------------------

(2)Kran in Standardausführung: ohne Hilfswinde, ohne Verlängerungen, Bereifung 14.00R24

GESCHWINDIGKEIT / BETRIEBSZEITENS ⁽³⁾

Winde (max. bei direktem Zug)	80 m/min
Heben/Senken des Teleskopauslegers	77 / 67 s
Ein-/Ausfahren des Teleskopauslegers (von 9.1 m auf 24.1 m)	92 / 40 s
Oberwagendrehung	25 s
Ausfahren eines Stützenträgers	4 s
Vollständiges Ausfahren eines Stützenträgers	10 s

(3)Durchschnittswerte, nur als unverbindliche Anhaltswerte zu verstehen

UNTERWAGEN

Antrieb/Lenkung	4x4x4
Rahmen	Rahmen mit zwei Kastenlängsträgern - Befestigungspunkt vorne (optional auch hinten)
Stützen	4 unabhängige, hydraulische Abstützungen auf hydraulisch ausfahrbaren Stützenträgern. Stabilisierung mit eingefahrenen, teilweise oder ganz ausgefahrenen Trägern. Steuerung von der Fahrerkabine
Motor	CUMMINS QSB 4.5 : 4-Zylinder-Reihenmotor - Hubraum 4.5 dm ³ - Turbolader. Höchstleistung 104 kW bei 2000 1/min - Max. Drehmoment 504 Nm bei 1800 1/min. Zertifizierung nach 2004/26/CE Stufe IIIA.
Tank	240 l
Antrieb	DANA Baureihe 20000: Typ Powershift mit Drehmomentwandler. 3+3 Vorwärtsgänge und 3+3 Rückwärtsgänge mit Anwahl des langsamen/schnellen Gangbereichs. Automatische Zuschaltung des Allradantriebs bei Anwahl des langsamen Gangbereichs.
Bremsanlage	Betriebsbremsen: doppelter Bremskreis mit hydropneumatischen Trommelbremsen an allen Rädern Feststell-/Notbremse: Pneumatische Negativ-Federbremse an der vorderen Gelenkwelle.
Achsen	2 Antriebs- und Lenkachsen mit Planetengetrieben in den Naben. Differentialsperre als Wunschausführung erhältlich.
Aufhängung	Starre Vorderachsaufhängung, Hinterachse schwenkbar. Automatische Sperrung der Hinterachsschwenkung über hydraulische Heber, wenn der Ausleger sich nicht im vorderen Bereich über der Mittellinie des Unterwagens befindet. Manuelle Sperrung der hinteren Schwenkung von der Fahrerkabine.
Lenkung	Hydrostatische Lenkung über Lenkrad in der Fahrerkabine. Vorderachsenlenkung oder konzentrische bzw. Krabben-Vollachsenlenkung.
Bereifung	4 Reifen 14.00R24. Als Wunschausführung 4 schlauchlose 16.00R25 (16.00-25)-Reifen.

OBERWAGEN

Ausleger	3 orthogonale Elemente
Hub	1 doppelt wirkender Hydraulik-Hubzylinder. Neigungswinkel des Auslegers -2° bis $+78^{\circ}$
Ausladung	Das 2. und 3. Element werden proportional und kontinuierlich mit einem doppelt wirkenden Hydraulik-Hubzylinder und einem internen Kettenvorgelegesystem ausgefahren. Ausfahren auch mit Teillast.
Seilwinde	Betätigung mittels Axialkolben-Hydraulikmotor mit festem Hubraum und Planetengetriebe. Automatische Negativbremse. Mit Seilklemme. Zwei Drehgeschwindigkeiten. Seildurchmesser 15 mm Länge 140 m. Max. Hubkraft 3800 daN. Als Wunschausstattung Hilfswinde mit denselben technischen Merkmalen wie die Hauptwinde. Seildurchmesser 15 mm.
Drehung	360° endlos mittels Hydraulikmotor und Planetengetriebe auf Drehkranz mit zwei Kugelreihen und Innenverzahnung. Automatische Negativbremse. Entsperrung der Bremse zur direkten Auslegerausrichtung auf die Senkrechte der zu hebenden Last.
Fahrerkabine	Gute Sicht, Schiebetür, Heizung. Front- und Dachscheibe mit Scheibenwischer. Dach- und Heckscheibe öffnenbar. Vollkommen einstellbarer Fahrersitz mit Federung und aufklappbaren Armlehnen, in denen die Manipulatoren für die Steuerung sämtlicher Kranmanöver angebracht sind.
Schutzvorrichtungen	Sperrventile an Ausfahr- und Hubzylindern des Auslegers und an den Abstützungen. Druckbegrenzungsventile in jedem Hydraulikkreis. Ausgleich- und Bremsventil am Drehwerk. Ausgleich- und Bremsventil an der Winde. Hubenschalter der Hakenflasche am Auslegerkopf. Endschalter zur Unterbrechung der Abwickelbewegung, wenn nur noch drei Seilwicklungen auf der Winde verbleiben. Lastmomentbegrenzer mit folgenden Angaben: Auslegerneigung Auslegerlänge Angehobene Last Max. zulässige Last

ANLAGEN

Hydraulikanlage	Speisung: 2 Doppelzahnradpumpen. Bewegungssteuerung Steuergeräte mit Betätigung über hydraulische Manipulatoren; gleichzeitige Proportionalbewegungen möglich. Steuerung der Kranabstützungen: Magnetventile mit Betätigung über separate Schalter. Filtration: 1 Einsatzfilter im Rücklauf. Ölkühlung mittels Wärmetauscher
Elektrische Anlage	24 V mit 70 A-Wechselstromgenerator und 2 Batterien zu 132 Ah. Beleuchtung nach EU-Richtlinien
Druckluftanlage	Kompressor zu 250 cm ³ , 2 Druckspeicher zu je45 l und Trockner. Zusätzlicher Luftanschluss und Reifenfüll-Set

HAUTAUSSTATTUNG

Gitterverlängerung, 0.7 + 7.3 m
Klimaanlage (warm / kalt) in der Fahrerkabine
Kit für Motorstart bei niedrigen Temperaturen
Optionale Zusatzwinde
Unterflasche 10 t
Haken 5 t

Bei Ihrem gebietszuständigen Händler können Sie eine vollständige Liste der Optionals anfragen.

DIAGRAMMA DI LAVORO / WORKING RANGES / DIAGRAMME DE TRAVAIL / ARBEITSBEREICHE







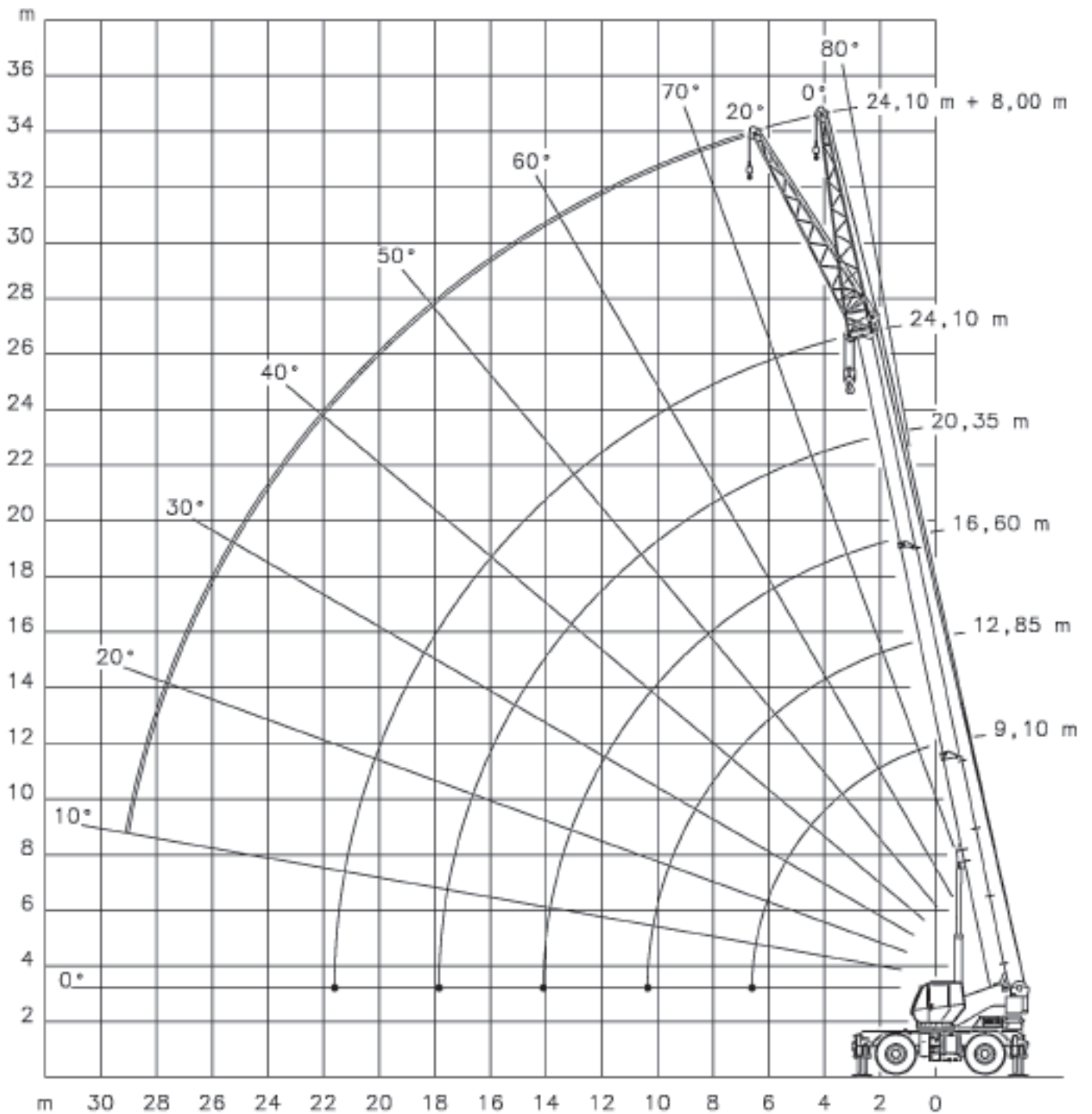

TABELLE / CHART / TABLEAU / TABELLE

				
5.80 m x 5.60 m	9.10 m ÷ 24.10 m	4.20 t	360°	









	t2 = 0%	t2 = 25%	t2 = 50%	t2 = 75%	t2 = 100%	
	t3 = 0%	t3 = 25%	t3 = 50%	t3 = 75%	t3 = 100%	
	9.10 m	12.85 m	16.60 m	20.35 m	24.10 m	
						
	32.00	30.30	20.30	16.45	8.80	
3.0	32.00	30.30	20.30	16.45	8.80	3.0
3.5	29.20	28.30	18.75	15.20	8.65	3.5
4.0	26.70	26.00	17.45	14.15	8.55	4.0
4.5	23.70	23.40	16.15	13.20	8.45	4.5
5.0	21.20	20.90	15.20	12.40	8.35	5.0
6.0	15.25	15.10	13.50	11.00	8.15	6.0
7.0		11.45	11.30	9.90	8.10	7.0
8.0		8.95	9.02	8.50	7.45	8.0
9.0		7.25	7.32	7.30	6.80	9.0
10.0		6.05	6.10	6.10	6.10	10.0
11.0			5.12	5.10	5.10	11.0
12.0			4.40	4.45	4.45	12.0
13.0			3.80	3.85	3.85	13.0
14.0			3.30	3.35	3.30	14.0
15.0				2.90	2.90	15.0
16.0				2.55	2.55	16.0
17.0				2.25	2.25	17.0
18.0					2.00	18.0
19.0					1.75	19.0
20.0					1.60	20.0
21.0					1.40	21.0
22.0					1.30	22.0
23.0						23.0
24.0						24.0

TABELLE / CHART / TABLEAU / TABELLE



14.00R24 – 16.00R25

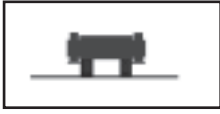

9.10 m ÷ 24.10 m



4.20 t



0 Km/h



360°



2 Km/h



0°













	t2 = 0%					t2 = 25%					t2 = 50%					t2 = 75%					t2 = 100%					
	t3 = 0%	t3 = 25%	t3 = 50%	t3 = 75%	t3 = 100%	t3 = 0%	t3 = 25%	t3 = 50%	t3 = 75%	t3 = 100%	t3 = 0%	t3 = 25%	t3 = 50%	t3 = 75%	t3 = 100%	t3 = 0%	t3 = 25%	t3 = 50%	t3 = 75%	t3 = 100%	t3 = 0%	t3 = 25%	t3 = 50%	t3 = 75%	t3 = 100%	
	9.10 m	12.85 m	16.60 m	20.35 m	24.10 m	9.10 m	12.85 m	16.60 m	20.35 m	24.10 m	9.10 m	12.85 m	16.60 m	20.35 m	24.10 m	9.10 m	12.85 m	16.60 m	20.35 m	24.10 m	9.10 m	12.85 m	16.60 m	20.35 m	24.10 m	
																										
	11.00	11.10	9.65	7.40	4.60	12.40	12.45	12.50	12.50		12.40	12.45	12.50	12.50		12.40	12.45	12.50	12.50		12.40	12.45	12.50	12.50		
3.0	11.00	11.10				12.40	12.45	12.50	12.50	3.0	11.00	11.10				12.40	12.45	12.50	12.50	3.0	11.00	11.10				
3.5	9.55	9.60	9.65			11.00	11.05	11.10	11.10	3.5	9.55	9.60	9.65			11.00	11.05	11.10	11.10	3.5	9.55	9.60	9.65			
4.0	8.35	8.45	8.45			9.85	9.90	9.95	9.95	4.0	8.35	8.45	8.45			9.85	9.90	9.95	9.95	4.0	8.35	8.45	8.45			
4.5	7.40	7.40	7.40	7.40		8.85	8.95	8.95	9.00	4.5	7.40	7.40	7.40	7.40		8.85	8.95	8.95	9.00	4.5	7.40	7.40	7.40	7.40		
5.0	6.25	6.25	6.25	6.25		8.05	8.10	8.15	8.15	5.0	6.25	6.25	6.25	6.25		8.05	8.10	8.15	8.15	5.0	6.25	6.25	6.25	6.25		
6.0	4.60	4.60	4.60	4.60	4.60	6.70	6.75	6.80	6.80	6.0	4.60	4.60	4.60	4.60	4.60	6.70	6.75	6.80	6.80	6.0	4.60	4.60	4.60	4.60	4.60	
7.0		3.60	3.60	3.60	3.60		5.40	5.40	5.45	7.0		3.60	3.60	3.60	3.60		5.40	5.40	5.45	7.0		3.60	3.60	3.60	3.60	
8.0		2.80	2.80	2.80	2.80		4.30	4.30	4.35	8.0		2.80	2.80	2.80	2.80		4.30	4.30	4.35	8.0		2.80	2.80	2.80	2.80	
9.0		2.25	2.25	2.25	2.25		3.45	3.50	3.55	9.0		2.25	2.25	2.25	2.25		3.45	3.50	3.55	9.0		2.25	2.25	2.25	2.25	
10.0		1.75	1.75	1.75	1.75		2.85	2.90	2.90	10.0		1.75	1.75	1.75	1.75		2.85	2.90	2.90	10.0		1.75	1.75	1.75	1.75	
11.0			1.45	1.45	1.45			2.40	2.45	11.0			1.45	1.45	1.45			2.40	2.45	11.0			1.45	1.45	1.45	
12.0			1.15	1.15	1.15			1.95	2.00	12.0			1.15	1.15	1.15			1.95	2.00	12.0			1.15	1.15	1.15	
13.0			0.90	0.90	0.90			1.65	1.70	13.0			0.90	0.90	0.90			1.65	1.70	13.0			0.90	0.90	0.90	
14.0			0.70	0.70	0.70			1.35	1.40	14.0			0.70	0.70	0.70			1.35	1.40	14.0			0.70	0.70	0.70	
15.0				0.55	0.55				1.15	15.0				0.55	0.55				1.15	15.0				0.55	0.55	
16.0				0.35	0.35				1.00	16.0				0.35	0.35				1.00	16.0				0.35	0.35	
17.0				0.25	0.25				0.80	17.0				0.25	0.25				0.80	17.0				0.25	0.25	
18.0										18.0										18.0						
19.0										19.0										19.0						
20.0										20.0										20.0						
21.0										21.0										21.0						
22.0										22.0										22.0						
23.0										23.0										23.0						
24.0										24.0										24.0						

TABELLE / CHART / TABLEAU / TABELLE



5.80 m x 5.60 m



9.10 m ÷ 24.10 m



4.20 t



360°



8.00 m

L + 8.00 m		L + 8.00 m	
0°		20°	
Max 78.0°		Max 78.0°	
78°	5.00		
77°	4.95	77°	3.65
76°	4.95	75°	3.50
75°	4.95	73°	3.35
73°	4.95	71°	3.20
71°	4.95	69°	3.10
69°	4.95	67°	3.00
67°	4.95	65°	2.90
65°	4.70	63°	2.80
63°	4.40	61°	2.70
61°	4.10	59°	2.60
59°	3.50	57°	2.50
57°	3.05	55°	2.30
55°	2.70	52°	2.05
52°	2.40	50°	1.85
50°	2.10	47°	1.65
48°	1.90	44°	1.45
45°	1.70	42°	1.30
43°	1.50	38°	1.15
40°	1.35	35°	1.00
37°	1.20	31°	0.90
34°	1.05	27°	0.80
31°	0.95	22°	0.65
27°	0.85	14°	0.55
23°	0.75		
18°	0.65		
11°	0.55		
6°	0.50		
0°	0.50	0°	0.50

TABELLE / CHART / TABLEAU / TABELLE

Outriggers fully extended Stabilisateurs en extension totale Stabilizzatori completamente estesi Voll ausgefahrene Abstützungen	Outriggers half-extended Stabilisateurs en extension partielle Stabilizzatori parzialmente estesi Teilweise ausgefahrene	Outriggers unextended Stabilisateurs fermés Stabilizzatori chiusi Eingefahrene Abstützungen	Load capacity on wheels Charges sur pneus Portate su pneumatici Tragfähigkeit auf Reifen	Traveling speed Vitesse de translation Velocità traslazione Bewegungsgeschwindigkeit
Telescopic boom Flèche télescopique Braccio telescopico Teleskoparm	Counterweight Contrepoids Contrappeso Gegengewicht	Upperstructure angle rotation Angle rotation structure du dessus Angolo rotazione sovrastruttura Drehwinkel des Strukturaufbaus	Upperstructure rotation lock Blocage rotation structure du dessus Rotazione sovrastruttura bloccata Bolzen des Strukturaufbaus	Extension / Jib Extension / Jib Prolunga / Jib Verlängerung / Jib

TAGLIE DI SOLLEVAMENTO / HOIST REEVING / MOUFLAGE / HUBROLLEN

N° di taglie / No. of line Nbr. de brins / Seilanzahl	1	2	3	4	5	6	7	8	9
--	---	---	---	---	---	---	---	---	---

ARGANO PRINCIPALE E AUSILIARIO / MAIN AND AUXILIARY WINCH / TREUIL PRINCIPAL ET AUXILIAIRE / HAUPTWINDE UND ZUSATZWINDE

Carico massimo in kN / Max line pull in kN Charges maxi en kN / Höchstlast in kN	38	76	114	152	190	228	266	304	342
---	----	----	-----	-----	-----	-----	-----	-----	-----

NOTE	NOTES	NOTES	HINWEISE
<p>I carichi indicati costituiscono i valori massimi coperti dalla garanzia del costruttore per utilizzo rispettivamente secondo le norme della Unione Europea (CE). Sono espressi in tonnellate metriche ed includono il peso del bozzello, delle eventuali prolunghe applicate al braccio e di tutti gli accessori di sollevamento (brache, ecc.) Le operazioni di sollevamento nella configurazione su gomme devono essere effettuate su superficie piana e solida con la corretta pressione di gonfiaggio degli pneumatici e con l'oscillazione dell'assale posteriore bloccata qualora l'operazione non avvenga con braccio entro un settore di +/- 3° rispetto all'asse di mezzeria della autogrù. Le operazioni di traslazione con carico possono avvenire esclusivamente con braccio allineato all'asse di mezzeria della autogrù, perno di bloccaggio meccanico della rotazione della sovrastruttura inserito e avendo cura di mantenere il carico stesso in prossimità della autogrù senza oscillazioni</p>	<p>The indicated loads are the maximum covered by the manufacturer's warranty for a use which complies with current EU directives (CE). Weights are given in metric tons. They include the weight of the block, all extensions fitted to the boom and all lifting accessories (slings and so on). Crane on wheels: operate the crane on a steady flat surface when hoisting loads and inflate tyres at proper pressure value. Also stop rear axle swinging if the load cannot be lifted having the arm within a +/-3° sector to the crane centreline. The load can be travelled only if the boom is aligned with the crane centreline, the shaft for upper structure rotation stop is fitted and the load is kept close to the crane and is not swinging.</p>	<p>Les charges indiquées constituent les valeurs maximales couvertes par la garantie du fabricant pour une utilisation conforme aux normes de l'Union Européenne. Elles sont exprimées en tonnes métriques et comprennent le poids de la moufle, des éventuelles extensions appliquées à la flèche et de tous les accessoires de levage (élingues, etc.). Les opérations de levage dans la configuration sur pneus doivent être effectuées sur une surface plane et solide avec une pression de gonflage des pneus correcte et l'oscillation de l'essieu arrière bloquée si l'opération n'a pas lieu avec la flèche située dans une zone de +/- 3° par rapport à l'axe de moitié du camion-grue. Les opérations de translation avec charge ne peuvent être effectuées qu'avec flèche alignée dans l'axe de moitié du camion-grue, goujon de blocage mécanique de la rotation de la structure du dessus enclenché et en prenant soin de maintenir la charge à proximité du camion-grue sans oscillations.</p>	<p>Die angegebenen Lasten sind die Grenzwerte, für welche die Herstellergarantie bei Einsatz gemäß den Normen der Europäischen Union (EU). Die Grenzwerte sind in Metertonnen ausgedrückt, das Gewicht des Blocks, eventueller am Ausleger angebrachter Verlängerungen und jeglicher Hebezubehörteile (Schlingen usw.) ist inbegriffen. Hebearbeiten mit bereiftem Kran müssen auf einer ebenen und festen Oberfläche erfolgen; die Reifen müssen richtig befüllt und die Hinterachse festgestellt sein, wenn der Ausleger außerhalb eines Bereichs von +/- 3° im Verhältnis zur Mittelachse des fahrbaren Krans gehoben wird. Transportarbeiten mit belastetem Ausleger sind ausschließlich erlaubt, wenn der Ausleger an der Mittelachse des Krans angereicht ist, der mechanische Verriegelungszapfen, der die Drehung des Oberwagens vermeidet, eingerastet ist und die Last ohne zu schwingen in Nähe des Krans behalten wird.</p>

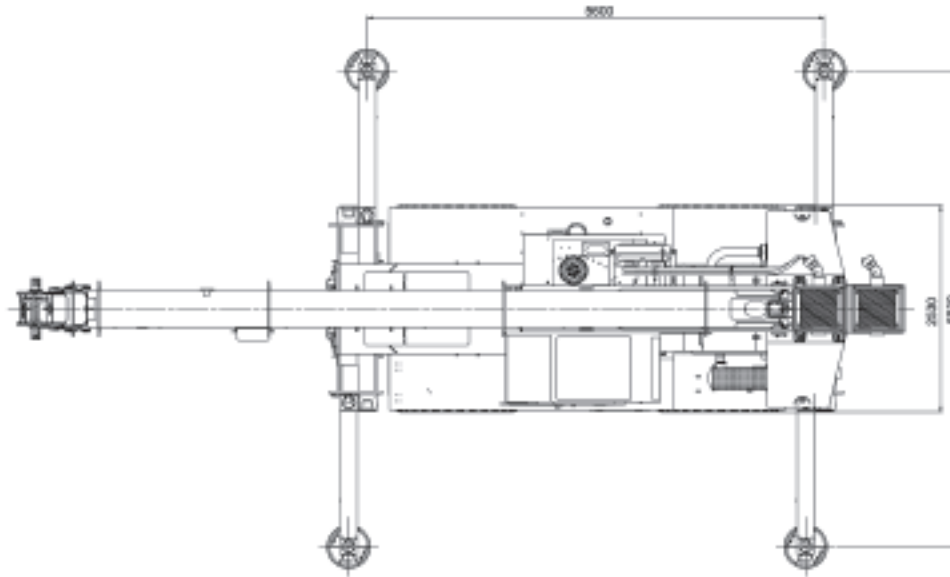
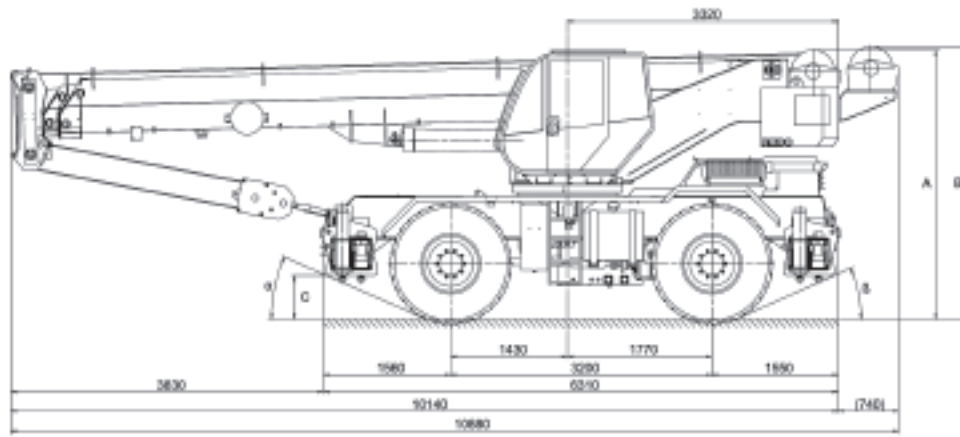

DIMENSIONI / DIMENSIONS / DIMENSIONS / ABMESSUNGEN ⁽⁴⁾

Pneumatici / Tyres Pneumatiques / Reifen	A	B	C	α	β
14.00R24	3245	3290	400	21°	21°
16.00R25	3295	3340	460	24°	24°

NOTE	NOTES	NOTES	HINWEISE
<p>Ci riserviamo il diritto di modificare le specifiche e i prezzi dei prodotti in ogni momento e senza preavviso. Le fotografie e/o i disegni contenuti in questo documento sono destinati unicamente a scopi illustrativi. Consultare le istruzioni sull'uso corretto di questo macchinario contenute nell'opportuno Manuale d'uso. L'inottemperanza delle istruzioni contenute nel Manuale d'uso del macchinario e altri comportamenti irresponsabili possono provocare gravi lesioni, anche mortali. L'unica garanzia applicabile ai nostri macchinari è la garanzia scritta standard applicabile al particolare prodotto e alla particolare vendita; Terex è esonerata dal fornire qualsiasi altra garanzia, esplicita o implicita. I prodotti e servizi elencati possono essere dei marchi di fabbrica, marchi di servizio o nomi commerciali di TEREX Corporation e/o società affiliate negli Stati Uniti d'America e altre nazioni e tutti i diritti sono riservati. "TEREX" è un marchio registrato di Terex Corporation negli USA e molti altri Paesi. Copyright © 2007 Terex Corporation.</p>	<p>Product specifications and prices are subject to change without notice or obligation. The photographs and/or drawings in this document are for illustrative purposes only. Refer to the appropriate Operations Manual for instructions on the proper use of this equipment. Failure to follow the appropriate Operations Manual when using our equipment or to otherwise act irresponsibly may result in serious injury or death. The only warranty applicable to our equipment is the standard written warranty applicable to the particular product and sale and Terex makes no other warranty, express or implied. Products and services listed may be trademarks, service marks or trade-names of Terex Corporation and/or its subsidiaries in the USA and other countries. All rights are reserved. Terex® is a registered trademark of Terex Corporation in the USA and many other countries. Copyright 2007 Terex Corporation.</p>	<p>Les spécifications et prix des produits sont sujets à modification sans avis ou obligation. Les photographies et/ou dessins contenus dans ce document sont uniquement pour illustration. Veuillez vous référer à la notice d'utilisation appropriée pour les instructions quant à l'utilisation correcte de cet équipement. Tout manquement au suivi de la notice d'utilisation appropriée lors de l'utilisation de notre équipement ou tout acte autrement irresponsable peut résulter en blessure corporelle sérieuse ou mortelle. La seule garantie applicable à notre équipement est la garantie standard écrite applicable à un produit et à une vente spécifique. Terex n'offre aucune autre garantie, expresse ou explicite. Les produits et services proposés peuvent être des marques de fabrique, des marques de service ou des appellations commerciales de Terex Corporation et/ou ses filiales aux Etats Unis et dans les autres pays, et tous les droits sont réservés. "TEREX" est une marque déposée de Terex Corporation aux Etats Unis et dans de nombreux autres pays. Copyright 2007 Terex Corporation.</p>	<p>Produktbeschreibungen und Preise können jederzeit und ohne Verpflichtung zur Ankündigung geändert werden. Die in diesem Dokument enthaltenen Fotos und /oder Zeichnungen dienen rein anschaulichen Zwecken. Anweisungen zur ordnungsgemäßen Verwendung dieser Ausrüstung entnehmen Sie bitte dem zugehörigen Betriebshandbuch. Nichtbefolgung des Betriebshandbuchs bei der Verwendung unserer Produkte oder anderweitig fahrlässiges Verhalten kann zu schwerwiegenden Verletzungen oder Tod führen. Für dieses Produkt wird ausschließlich die entsprechende, schriftlich niedergelegte Standardgarantie gewährt. Terex leistet keinerlei darüber hinaus gehende Garantie, weder ausdrücklich noch stillschweigend. Die Bezeichnungen der aufgeführten Produkte und Leistungen sind gegebenenfalls Marken, Service-marken oder Handelsnamen der Terex Corporation und/oder ihrer Tochtergesellschaften in den USA und anderen Ländern. Alle Rechte vorbehalten. "TEREX" ist eine eingetragene Marke der Terex Corporation in den USA und vielen anderen Ländern. Copyright 2007 Terex Corporation.</p>



TEREX ITALIA S.r.l. - Via Cassoletta 76
40056 Crespellano BO - ITALY
Tel.: (+39) 051 6501011
Fax: (+39) 051 734645
internet: www.terex.it
e-mail: terexitalia@terex.it

ISO 9001 - Cert. 1151/2

cod.44928 - rev.04 del 06/09

