

NOTE: Cabin height is 2916mm when front frame with higher corner piece is used.

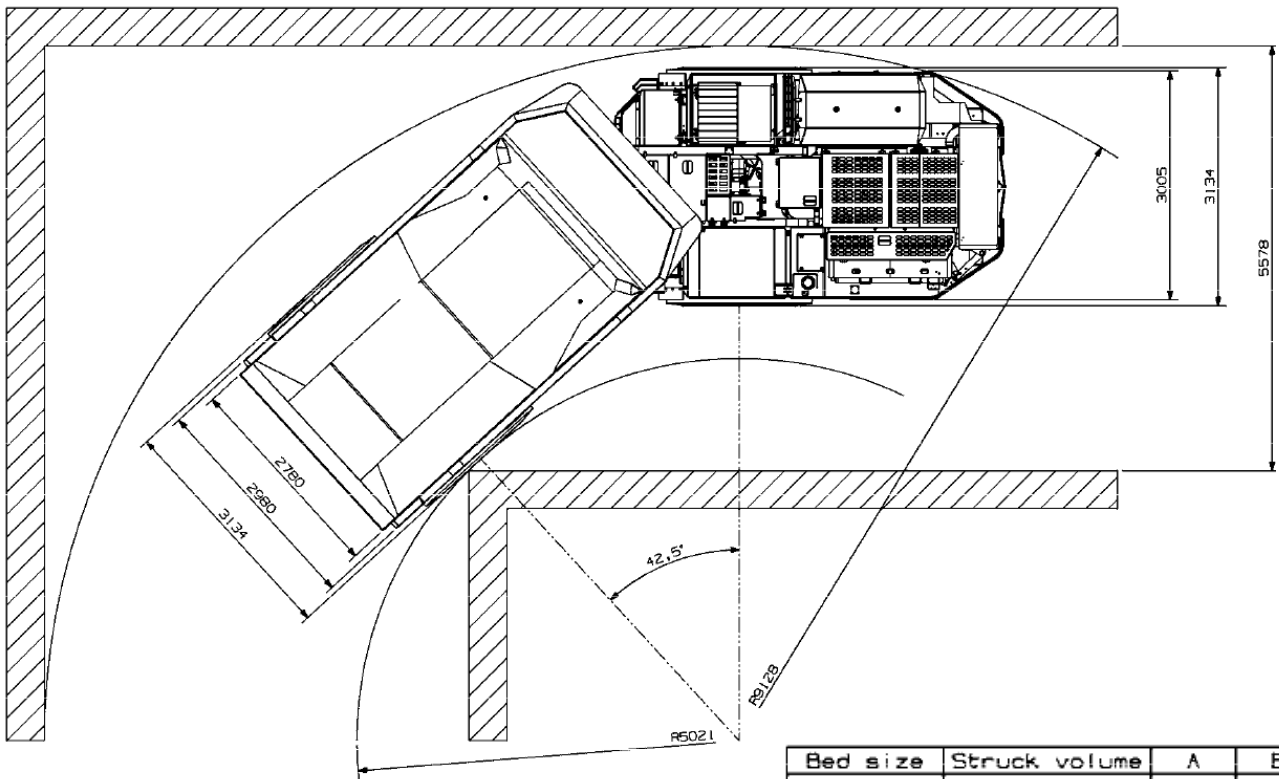

Bed size	Struck volume	A	B
18m <sup>3</sup>	14,7m <sup>3</sup>	6080	2705
20m <sup>3</sup>	16,6m <sup>3</sup>	6131	2856
22m <sup>3</sup>	18,5m <sup>3</sup>	6201	3005

Sandvik Mining and Construction reserves the right to change this specification without further notice

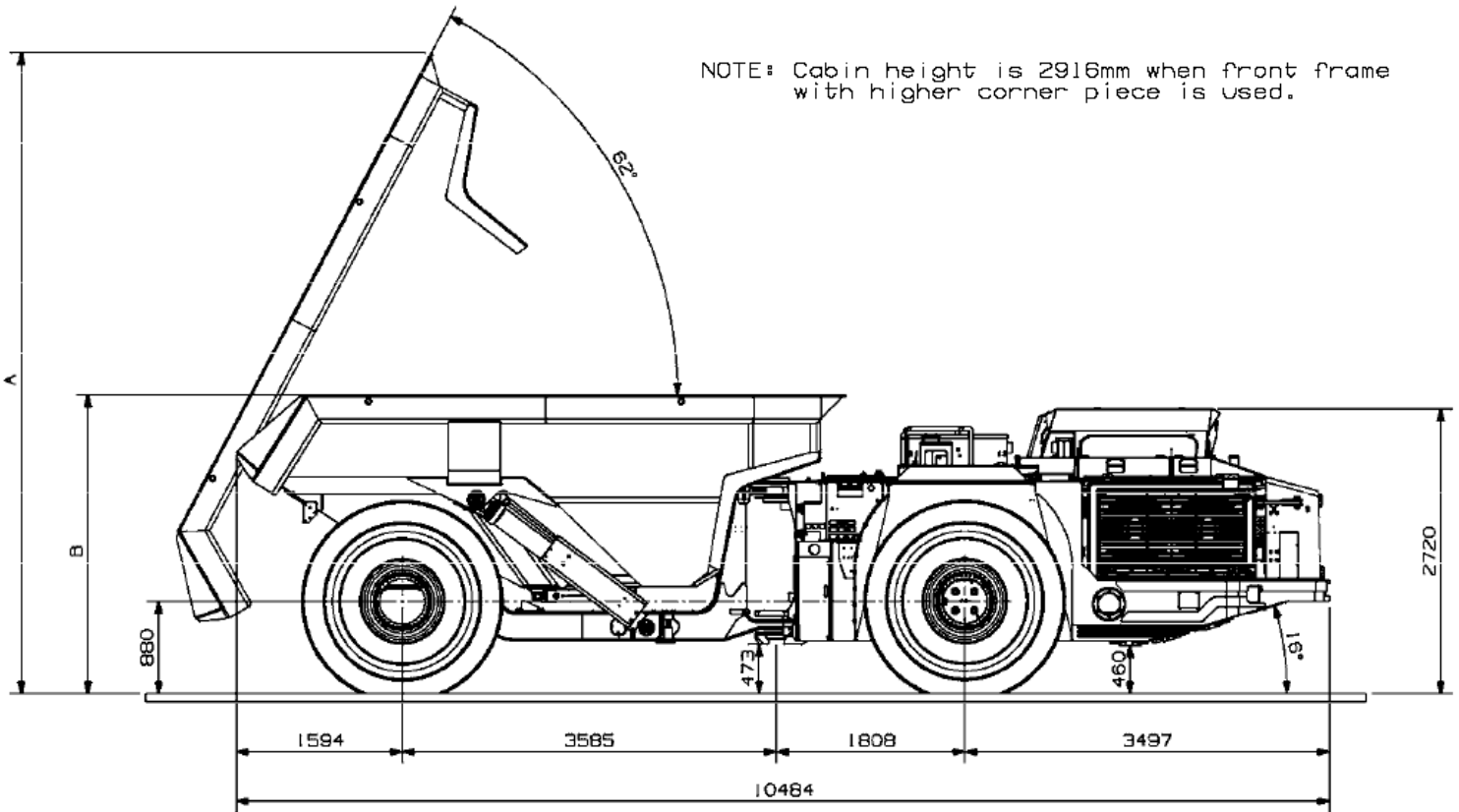

Sandvik Mining and Construction Oy  
P.O. Box 434  
20101 Turku, Finland  
Tel. +358 205 44 131  
Fax +358 205 44 130  
www.smc.sandvik.com

## Main dimensions

Total length	10 484 mm (413 in)
Total width	3 134 mm (123 in)
Height	2 720 mm (107 in)
Max. height of the box 20 m <sup>3</sup>	2 856 mm (112 in)

## Weights

Operating weight	35 900 kg (79 150 lb)
Total loaded weight	85 900 kg (189 380 lb)
Axle weights without load:	
front axle	26 300 kg (58 000 lb)
rear axle	9 600 kg (21 160 lb)
Axle weights with load:	
front axle	40 500 kg (89 300 lb)
rear axle	45 400 kg (100 090 lb)

Unit weight is dependent on the selected options

## Capacities

Payload capacity*	50 000 kg (110 232 lb)
Box sizes (heaped, SAE J1363)	20 m <sup>3</sup> (26 yd <sup>3</sup> )

## Dump box movements

Dumping time	14,0 sec
Dumping angle	62°

## Driving speeds forward and reverse

1st gear	5.9 km/h (3.7 mph)
2nd gear	7.8 km/h (4.8 mph)
3rd gear	10.6 km/h (6.6 mph)
4th gear	13.8 km/h (8.6 mph)
5th gear	18.3 km/h (11.4 mph)
6th gear	24.0 km/h (14.9 mph)
7th gear	32.0 km/h (19.9 mph)
Reversing with 1st and 3rd gear	

## Frame

Rear and front frame	Welded steel construction
Central hinge	Box constructed, adjustable lower bearing

## Standard engine

Diesel engine	Volvo TAD1660VE (MSHA approved)
Output	405kW (551 hp) / 2100 rpm
Torque	2703Nm (1993 lbf ft) / 1350 rpm
Number of cylinders	in line 6
Displacement	16.12 l
Cooling system	Water cooled
Combustion principle	Direct injected, turbo + inter cooler, 4- stroke
Air filtering	Donaldson
Exhaust system	Heat shield for exhaust manifold & Turbo, Double wall exhaust pipe, Catalytic purifier and muffler
Fuel tank capacity	700 l (185 gal.)
Engine shut down with low hydraulic or brake oil level	

## Standard converter

Dana CL 9672	One stage, Offset 1:1. With lock-up
--------------	-------------------------------------

## Gearbox

Dana 8821	Power shift transmission with electric remote shifting system. Seven gears forwards and two reverse. Automatic gear shifting
-----------	--

## Standard axles

Front axle	Dana, 53R300, oscillation ±13°.
Rear axle	Dana, 53R300, fixed

## Standard tyres

Size and type	29.5R25 E4 ** Brand and type subject to availability)
Air pressure	front 550 kPa (5.5 bar) (80 psi) rear 700 kPa (7.0 bar) (102 psi)

Other type of tyres available to user's choice. In certain applications the productive capabilities of the truck may exceed the TKPH value given by tyre manufacturer.

Sandvik Mining and Construction Oy recommends that the user consult their tyre supplier to evaluate conditions and to find the best solution for application.

## Cabin

ROPS/FOPS certified safety cabin with air conditioning	
Height	2720 mm (107")

## Steering hydraulics

Full hydraulic, center articulated, power steering with two double acting cylinders. Steering is equipped with load sensing Danfoss system and a steering wheel.

Turning angle	± 42.5°
Turning radius, inner	4836 mm (190")
Turning radius, outer	9130 mm (359")

Main components in steering system:

Steering pump	
Steering cylinders	
Steering valves	
Pressure setting for steering hydraulic circuit	19,0 MPa (190 bar)
port relief valves	24,0 MPa (240 bar)

## Box hydraulics

Full hydraulic pilot controlled system, equipped with variable displacement piston pump. Oil flow to box hydraulic system from the steering hydraulics. Oil flow from the brake circuit pump is divided to the brake system and oil cooler motor.

Pressure setting for:	
pilot circuit	3,5 MPa (35 bar)
dump box hydraulics	26,0 MPa (260 bar)
port relief valves:	
piston end	28,0 MPa (280 bar)
piston rod end	12,5 MPa (125 bar)

Main components:

Cylinders for dump box	
Valves for dump box	
Pump for dump box hydraulics	
Pump for brake and cooling circuit	
Fittings	ORFS
Hoses	High temperature
Steel piping hydraulics	
Oil cooler for hydraulic oil	
Steering and box hydraulic oil tank capacity	225 liters (60 gal)
Electrical fill up pump for hydraulic oil	

### Standard brakes

Service brakes are spring applied, hydraulically released multidisc wet brakes (Posi-Stop) on all wheels, two separate circuits for the front and rear axle. Service brakes also function as an emergency and parking brake. Electrically driven pump for brake emergency/towing releasing.

Main components in the brake system:

- Pressure accumulator
- Brake pedal valve
- Brake valve
- Charging valve

Brake hydraulic tank capacity                      100 liters (26.4 gal)  
Automatic brake activation (ABA)

### Standard Lubrication system

Centralized automatic lubrication

### Electrical equipment

Alternator	2 pcs, 28 V 140A Bosch
Batteries	2 pcs, 12 V 160 Ah
Starter	24 V
Driving lights	4 pcs in front (H3 65W) 4 pcs in rear (H3 65W)
Working light	1 pc (H3 65W)
Parking lights	4 pcs
Brake lights	2 pcs
Blinkers	4 pcs
Instrumentation	5.7 in LCD display

### Safety equipment

- Signal horn for box up
- Hand held fire extinguisher 12 kg
- Engine shut down with low hydraulic or brake oil level
- Reverse alarm (CEN)
- Lockable main switch
- External shutdown
- Neutral brake

### Others

Decal language    EU-languages

### Standard manuals

Instructions Manual	
-Operator's Manual	EU-languages
-Maintenance Manual	EU-languages
Parts Manual	English
Service and Repair Manual	English
ToolMan CD, (2 pcs)	In pdf format
-Instructions Manual	
-Operator's Manual	
-Maintenance Manual	
-Parts Manual	
-Service and Repair Manual	

### Main options:

- \* Replaces standard equipment
- \* Engine Volvo TAD1660VE 450kW (550 hp), Euro Stage 3B / Tier 4i (Only for EU & Japan)
- \* Engine DETROIT S60, 429 kW (575hp), (MSHA approved)
- \* Dump box capacity 22,0m<sup>3</sup> (29 yd<sup>3</sup>) (heaped, SAE J1363), width 2760/2980mm.
- \* Dump box capacity 25.5m<sup>3</sup> (33 yd<sup>3</sup>) (heaped, SAE J1363), width 3260/3480mm.
- \*Dump box capacity 28.0m<sup>3</sup> (37 yd<sup>3</sup>) (heaped, SAE J1363), width 3260/3480mm.
- Emergency steering (CEN).
- Electrical retarder TELMA.
- Exhaust brake "Jake Brake"
- Gear limit TBA
- Fire suppression system ANSUL, two tank system with 8 nozzles (CEN) including auto engine shut down.
- Fire suppression system ANSUL, two tank system with 8 nozzles (CEN), CHECKFIRE including auto engine shut down.
- Sandvik FS1000 fire suppression system including auto shut down
- Reverse camera
- Mirrors defrost
- Windows defrost
- Cabin heater (with air conditioning)
- Cyclone for air conditioning
- Cover grills for lights
- Wiggins fuel fill system
- Wiggins fluid fill set (hydr., transmission and engine oil)
- Jump start (CAT)
- Flashing beacon
- Foldable safety rails
- Accordance with CE-norms (CEN).
- Disassembly needed shaft dim: TBA.
- CatBase/LinkOne spare part manuals and additional Instructions, Workshop, Spare part manuals, ToolMan CD's are available.
- Control system tool kit