

Hydex

Customised Articulated Trucks

Hooklift

Sideboard Extensions

Fuel Tank

Water Tank

Fuel & Lube Truck

Special Body



Articulated trucks for specialist applications

Articulated Truck Solutions LLP

Design • Develop • Deliver • Depend

Articulated Truck Solutions – specialist application experts

Articulated Truck Solutions – offering its range of Hydrex products – has been established to provide the CAT® dealer network with innovative, high quality products and special application solutions which extend the standard factory product range.

Based in the United Kingdom, Articulated Truck Solutions designs and sells a number of special product variations for CAT® articulated trucks, focusing on niche markets and specific industries.

We offer our solutions on both new and used equipment and only through the Caterpillar® dealer network. With an experienced team in design and application engineering, sales and product support are proud to be associated only with Caterpillar®.

All Hydrex products are designed, produced and assembled to the highest quality standard, including CE marking where applicable, to ensure efficient operation and long product life.

Design • Develop • Deliver • Depend.





Built on the world-leading Cat chassis

Front Frame

The front frame design features a large box section and wide, stiff frame beams to handle torque loads. The divergent frame design decreases stress in the hitch area and optimizes suspension geometry. The frame design makes maximum use of robotic welding for increased durability.

Rear Frame

Twin-box construction minimizes stress concentrations and provides low weight with long service life.

Suspension

The three-point oscillating axle front suspension provides unparalleled ride quality. It also protects the truck from adverse road conditions by absorbing shock loads that would reach the frame.

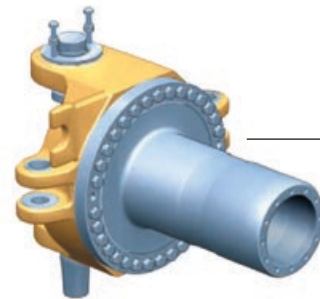
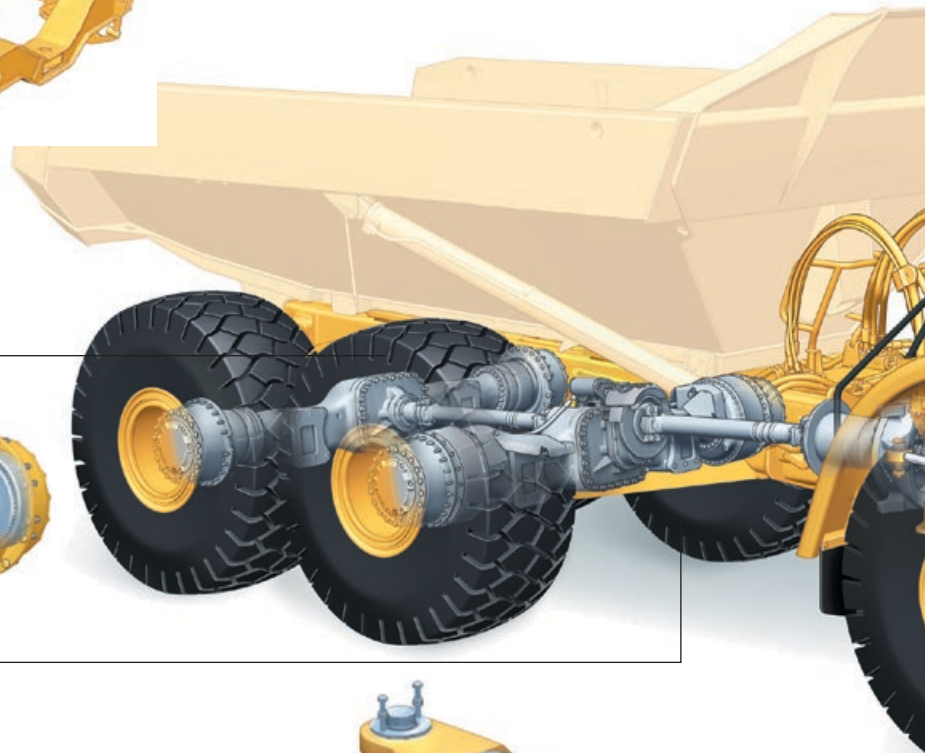
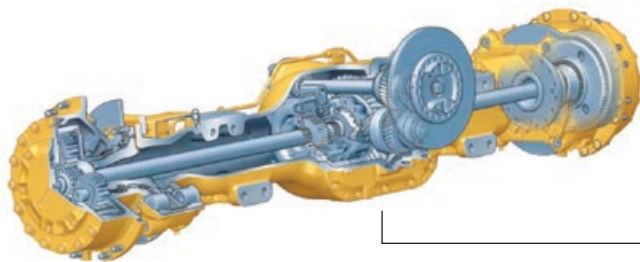
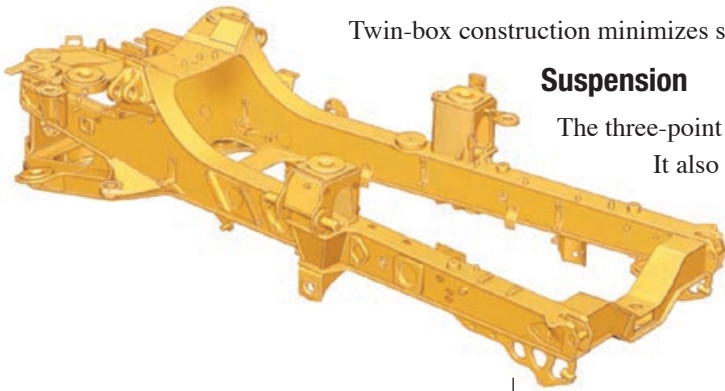

Traction Control

The traction control system is comprised of a wet clutched inter-axle differential and wet clutched cross-axle differentials. All differentials can be engaged and disengaged “on-the-go” for maximum versatility. When used together, the differentials provide 100 percent driveline locking.

Inter-Axle Differential Lock

Locks all three axles in unison and modifies torque distribution for excellent traction in poor underfoot conditions and on grades. It is operated by a switch located at the footrest.

Cross-Axle Differential Locks

Provides full driveline locking – all three axles and all six wheels – for maximum performance in the most adverse conditions. Acts in unison with the inter-axle differential lock when the footswitch is actuated and the dash-mounted switch is selected.

Articulating/Oscillating Hitch

The articulating hitch provides the truck with steering articulation, and the oscillation ensures all-wheel ground contact in rough terrain.

Hitch Construction

Two-piece construction features a durable cast steel head bolted to a hard-wearing forged steel tube.



Ride Comfort

The three-point front suspension with its oscillating axle and low-pressure ride struts, combined with the centre-mounted cab, offers unrivalled levels of ride comfort for the operator in all driving conditions.

Spacious Two-Person Cab

The chassis features a large two-person cab, offering comfortable working space for both the operator and trainer or trainee. All 700 Family articulated trucks use the same spacious cab design.

Air Suspension Seat

The air suspension seat enhances operator comfort with a cushioned upper high back, adjustable damping with three settings, ride zone indicator and adjustable lumbar settings. It is fully adjustable to provide the optimal driving position.

Trainer Seat

Full-size trainer seat features a fully padded seat with a backrest and a wide seat belt for a secure and comfortable ride. The trainer seat is positioned next to the operator seat, giving both the operator and trainer a clear view of the instrument panel, controls and the road.

Steering Column

A comfortable driving position is provided by a telescopic and tilt adjustable steering column.

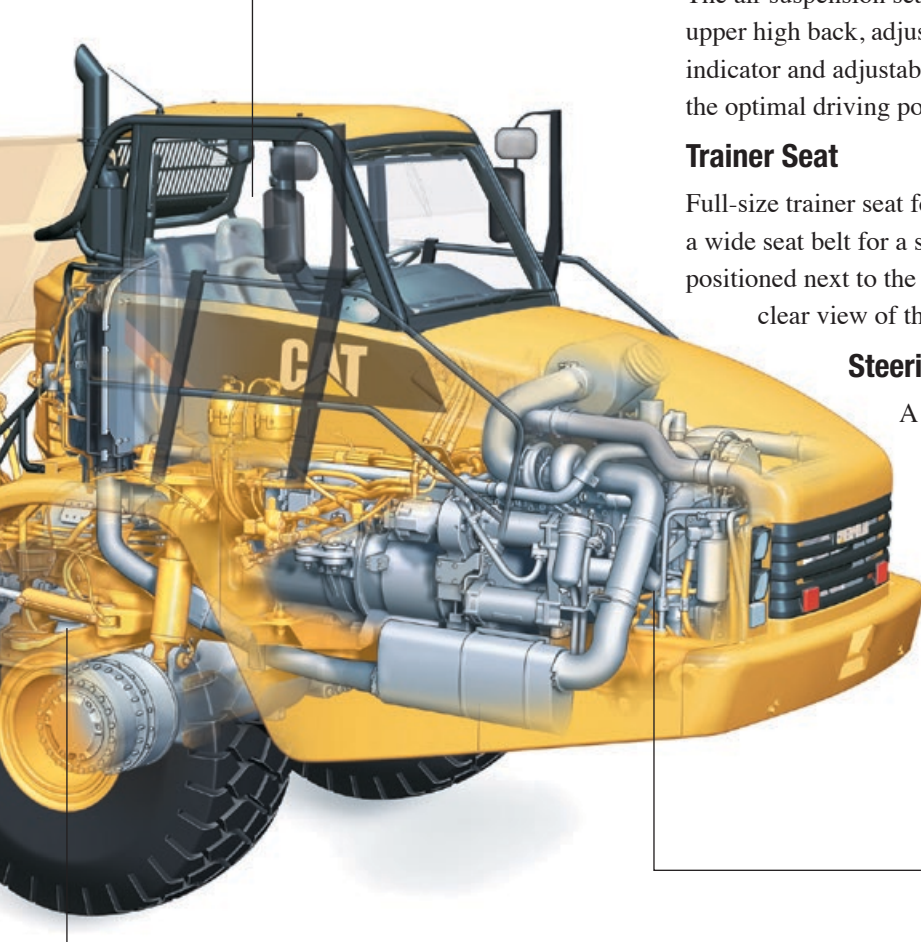

ACERT Technology

The Cat® ACERT® engine introduces a series of evolutionary, incremental improvements that provide breakthrough engine technology built on systems and components developed by Caterpillar with proven reliability.

Fuel Delivery

Multiple injection fuel delivery involves a high degree of precision. Precisely shaping the combustion cycle lowers combustion chamber temperatures, generating fewer emissions and optimizing fuel combustion. This translates into more work output for your fuel cost.

Noise Reduction Technologies

Noise reduction has been achieved through design changes to the isolated top cover, oil pan, multiple injection strategy, insulated timing case cover, sculpted crankcase and gear train refinements.

Chassis options and product range

Tanks

The **Hydex WT** range is a complete line of water trucks from Articulated Truck Solutions. More than just a water tank, it's a water truck; an integrated machine designed for dust suppression on the most demanding mining, quarrying and construction sites.



Tank Capacities		
Model	Capacity	
WT25	18900 Ltr	5000 US Gal
WT30	22700 Ltr	6000 US Gal
WT35	26500 Ltr	7000 US Gal
WT40	30300 Ltr	8000 US Gal
WT40 LWB	34000 Ltr	9000 US Gal

- Tank designed for lowest centre of gravity
- Multiple rows of baffling in both transverse and longitudinal directions
- Up to 1500 GPM hydraulic driven water pump
- Rear spray bar with up to four fully adjustable fan spray heads with individual cab mounted hydraulic controls
- Two side spraying heads mounted on front of tank
- Self-loading system
- Remote controlled turret water cannon.
- Interior of tank coated with Epoxy
- Fire Eater system; includes built in foam tank and adjustable nozzle for water and foam

Fuel and Lube

The **Hydex FLT** range is a complete line of service trucks from Articulated Truck Solutions. Available as fuel tanker truck, service truck or any combination in between which can be customised to your site requirements. The **HYDEX FLT** is an integrated machine designed for use on the most demanding mining, quarrying and construction sites.



- Full product filtration
- Ground level remote fill
- Tank level gauges
- Exterior and interior lighting packages
- Enclosed rear or side reel compartments
- Sprung, hydraulic or electric reels
- New and used filter storage
- Fully baffled product tanks
- Product metering systems

Side Extensions

The **Hydex Side Extension** modification has been designed to offer increased capacity to the standard CAT® articulated truck dump body. These extensions can be used to improve various applications; these include reducing spoil spillage when carrying a standard sized load or increasing the volumetric capacity of the body if a lighter weight material is being carried.



- 200mm / 250mm body extension (customizable)
- Optional extended tailboard and headboard infill
- Welded or removable bolt-on design using CAT® hardware.

Hooklift

The **Hydex HL23** and **HL30** are designed for loading, unloading and tipping a range of containers and bodies. With a Hydex hooklift truck a whole other range of operations can be safely fulfilled, for example, for moving, carrying and operating attachments such as water tanks, field service units, ISO containers, fire suppression units as well as special dirt dumper bodies and traditional containers. In fact it is possible to design a specific attachment to suit your individual needs making the Hydex hooklift into a truly multipurpose machine.



- Rated payload HL23: 23.6 tonne / 26 ton
- Rated payload HL30: 30 tonne / 33 ton
- Heavy duty rollers
- Safety interlocks
- Integrated in cab controls with warning lights and safety alarm
- Attachment options available – dump body, flat bed, fuel or water tanks, service units

Special Application On-Highway Approval

The **Hydex Road Homologated Narrow Body Truck** from Articulated Truck Solutions is modified for road use or easy road transport to your country's specific requirements. This conversion includes a new Hydex narrow body with added optional equipment to suit your specification. Available for 730, 735, and 740 CAT® articulated dump trucks.



- New narrow body – under 3000 mm
- Additional road lighting: front, side and rear
- Automatic hydraulic rear under run bumper
- Bolt-on side boards
- New scissor tailgate



Specialist Bodies

The **Hydex HC** range of truck bodies is purpose-built for the mining, quarrying and waste industries. Being built from the same Hardox® steel as the standard CAT® dump bodies the Hydex HC bodies offer a durable and tough solution for many other specialist material applications.

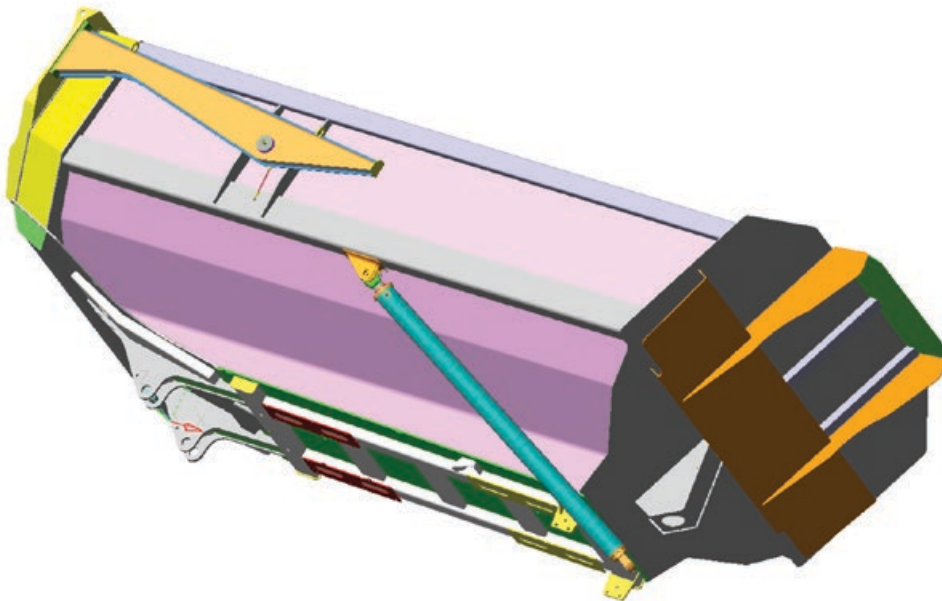

- Coal
- Flyash
- Slag
- Trash / Waste
- Narrow
- Flatbed
- Timber

Chassis options and product range

Standard Caterpillar Factory Products

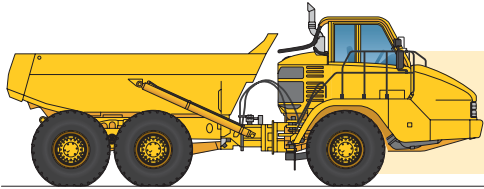

Caterpillar Articulated Truck

Models 725 730 735 740

Caterpillar OEM Solution Group cab chassis options



Wheelbase Option
Model

Standard
725 730 735 740



Wheelbase Option
Model

Long
725 730 735 740

Articulated Truck Solutions Products

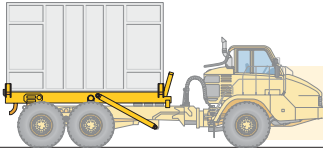

Product Type: **Container Carrier**
Models: CC35 • CC40

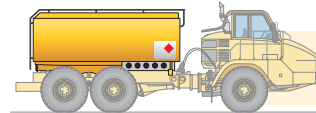

Product Type: **Fuel Tanker**
Models: FT25 • FT30 • FT35 • FT40



Product Type: **Hook Lift**
Models: HL23 • HL30

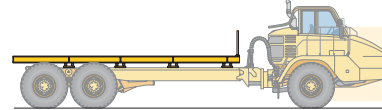

Product Type: **Flatbed**
Models: 25 • 30 • 35 • 40

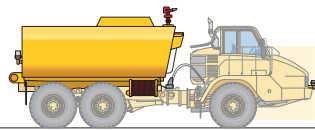

Product Type: **Water Tank**
Models: WT25 • WT30 • WT35 • WT40

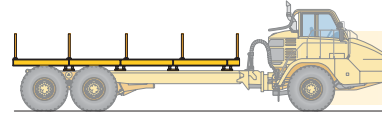

Product Type: **Pipe Carrier**
Models: 25 • 30 • 35 • 40



Product Type: **Lube & Service Truck**
Models: FLT40

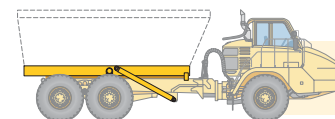

Product Type: **Special Body ***
Models: 25 • 30 • 35 • 40



Product Type: **Concrete Mixer**
Models: CM25 • CM30

* Special Body Options:

Flyash • Coal • Narrow Homologated • High Capacity Waste
• Scrap • Slag • Rock

Other applications are available, designed to suit customer requirements.

Chassis specifications

Standard equipment may vary. Consult your Caterpillar dealer for details.



Air conditioning with R134A refrigerant
Air vents, adjustable
Auto shift transmission
Automatic Traction Control (ATC)
on 735B and 740B
Back up alarm
Cat engine with ACERT Technology
Caterpillar Work Area Vision System
(WAVS) rear-view camera
CD/Radio ready
Differentials, standard with clutched crossaxle
differential locks for all axles*
Dual circuit caliper disc brakes – all wheels
(725 & 730)
Oil-cooled brakes, enclosed (735B & 740B)
Electrical system: 24 volt, 5A 24- to 12 volt
converter
Electro hydraulic hoist control
Ether starting aid
Glass windows, laminated and tinted (front),
toughened and tinted (rear)
Guards: rear window and radiator, crankcase
and axle
Headlights, four
Heater and defroster with four-speed fan

Horn, electric
Lights: cab interior, front, side, rear, two
reversing/working lights, two stop/tail lights,
front and rear direction indicators
Mirrors, main and auxiliary, left and right
Mud flaps, wheel arch and body mounted, with
transportation tie backs
Product Link (US/Canada/Europe/Turkey/
Australia/New Zealand)
Retarder
Engine compression brake (735B & 740B)
ROPS/FOPS cab, with full instrumentation,
including:
– Instrument cluster display module
– Indicator lamps: left turn, secondary steering,
primary steering loss, front and rear brake
temp (735B/740B and 740B Ejector only),
brake oil pressure, action lamp, transmission
fault, park brake, charging system status,
differential lock, body not in float, right turn,
high beam, transmission hold, machine filter
warning, retarder, retarder up shift warning
– Gauges: engine oil pressure, engine coolant
temperature, torque converter
– Meters: service hour meter, speedometer,
tachometer

Seat, fully adjustable, air suspension seat,
padded companion/trainer
Secondary steering – electronic
S•O•SSM sampling valves
Spill guard, front, integral part of fabricated
body
Starting receptacle, electric, remote
Storage: two cup holders, flask receptacle
under seat storage, door pocket, behind seat
storage, coat hook
Sun visor
Three axle, six-wheel drive
Tilt and telescopic steering wheel
Tires
– Six 23.5R25, radial (725 & 730)
– Six 26.5R25, radial (735B)
– Six 29.5R25, radial (740B)
Tow pins, front and rear
Two seat belts, operator's retractable
Vandalism Protection: lockable caps for fuel
tank and hydraulic oil tank
Windows opening side, tinted
Windshield wiper and washer, two speed,
intermittent (front)

Standard Chassis Optional Equipment

Autolube installation for automatic greasing
of bearings
CD/Radio, heavy duty
Cold Weather Coolant –51° C (–60° F)

Cold weather start kit
Cycle counter/operator monitoring kit
Engine Block Heater
Fast fuel fill

Flashing Xenon Beacon
Fuel Additive-Anti-Waxing
Heated rear-view mirrors
Tires, six 750/65 (725 & 730)

* Automatic on 735B and 740B

Chassis dimensions

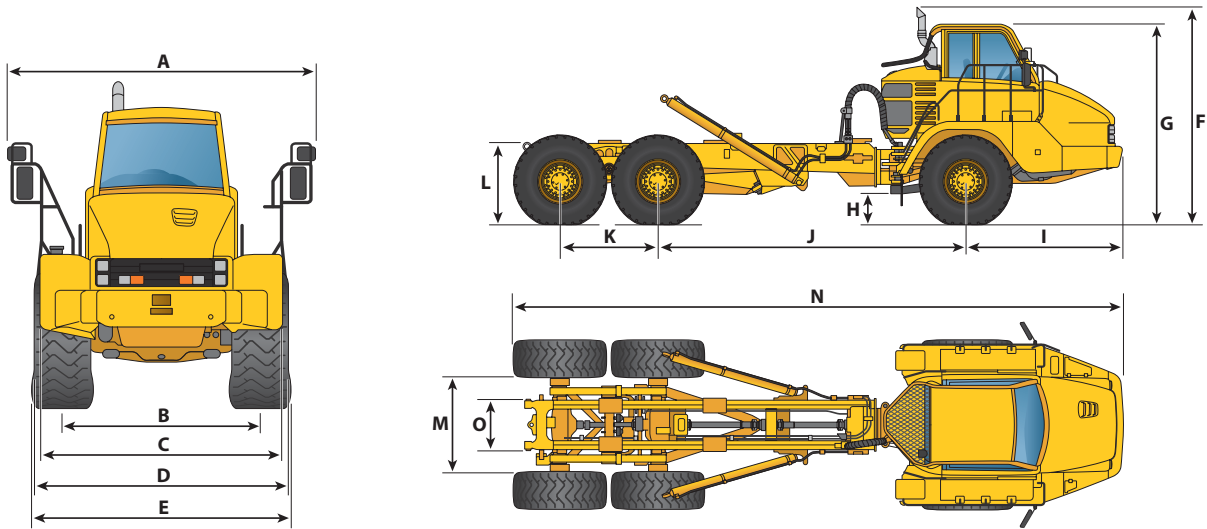

Cat 725								
	SWB	LWB		SWB	LWB		SWB	LWB
A	3645	3645	F	3751	3751	K	1700	1700
B	2275	2275	G	3440	3440	L	1436	1436
C	2800	2800	H	495	495	M	1626	1626
D	2877	2877	I	2721	2721	N	9068	10554
E	2950	2950	J	3818	5305	O	835	835

Cat 730								
	SWB	LWB		SWB	LWB		SWB	LWB
A	3645	3645	F	3751	3751	K	1700	1700
B	2275	2275	G	3440	3440	L	1436	1436
C	2800	2800	H	495	495	M	1626	1626
D	2877	2877	I	2721	2721	N	9068	10554
E	2950	2950	J	3818	5305	O	835	835

Cat 735								
	SWB	LWB		SWB	LWB		SWB	LWB
A	3832	3832	F	4006	4006	K	1966	1966
B	2687	2687	G	3703	3703	L	1573	1573
C	3370	3370	H	534	534	M	2021	2021
D	3353	3353	I	3221	3221	N	10301	11856
E	3434	3434	J	4244	5800	O	1031	1031

Cat 740								
	SWB	LWB		SWB	LWB		SWB	LWB
A	3823	3823	F	4049	4049	K	1966	1966
B	2687	2687	G	3745	3745	L	1626	1626
C	3370	3370	H	577	577	M	1944	1944
D	3430	3430	I	3221	3221	N	10355	11911
E	3520	3520	J	4244	5800	O	1031	1031

SWB: Standard Wheelbase **LWB:** Long Wheelbase

Conversion options

Cat 725
Body Options
<ul style="list-style-type: none"> • Flyash • Scrap • Slag • Waste/Trash
Tank Options
<ul style="list-style-type: none"> • Fuel: 5000 US gal / 19,000 litres • Water: 5000 US gal / 19,000 litres
Hooklift
Service Truck

Cat 730
Body Options
<ul style="list-style-type: none"> • Flyash • Narrow • Waste/Trash • Scrap • Slag
Tank Options
<ul style="list-style-type: none"> • Fuel: 6000 US gal / 23,000 litres • Water: 6000 US gal / 23,000 litres
Service Truck
Road Homologation

Cat 735B
Body Options
<ul style="list-style-type: none"> • Flyash • Narrow • Waste/Trash • Scrap • Slag
Container Carrier
Tank Options
<ul style="list-style-type: none"> • Fuel: 7000 US gal / 26,500 litres • Water: 7000 US gal / 26,500 litres
Service Truck
Hooklift

Cat 740B
Body Options
<ul style="list-style-type: none"> • Coal • Flyash • Waste/Trash • Scrap • Slag
Container Carrier
Tank Options
<ul style="list-style-type: none"> • Fuel: 8000 US gal / 30,500 litres 9000 US gal / 34,000 litres • Water: 8000 US gal / 30,500 litres 9000 US gal / 34,000 litres
Service Truck

Additional solutions are available to suit your job requirements. Please contact us to discuss your needs.

Notes

Your Application : Our Solutions

Articulated Truck Solutions – offering its range of Hydex products – is established to provide the CAT® dealer network with innovative, high quality products and special application solutions which extend the standard factory product range.



HEAD OFFICE

Articulated Truck Solutions LLP

Twyford Business Centre
London Road
Bishop's Stortford
Herts CM23 3YT
United Kingdom

Telephone: +44 (0)1279 755590
Fax: +44 (0)1279 756117
Email: info@hydexus.com
Web: www.hydexus.com

Latin America

Telephone: +54 911.62.493343
Email: latinamericasales@hydexus.com

US and Canada

Telephone: 1-800-584-3198
Email: ussales@hydexus.com

EAME and ROW

Telephone: +44 (0)1279 755590
Email: info@hydexus.com

Your nearest authorized dealer is:

Materials and specifications are subject to change without notice.

See your Caterpillar dealer for standard and optional cab equipment.

Hydex is a registered trademark.

CAT, CATERPILLAR, ACERT, their respective logos, "Caterpillar Yellow" and the POWER EDGE trade dress, as well as corporate and product identity used herein, are trademarks of Caterpillar and may not be used without permission.