

CC30

Hydex

Container Carrier Articulated Truck

The **HYDEX CC30** is designed for hauling 20ft ISO Containers.

Based on the Cat 730 Articulated Truck chassis offering proven reliability and durability, high class performance and productivity, optimum payload, operator comfort and ease of operation.



- Headboard for container frame
- Safety interlock
- Container corner guards
- Light in cab to confirm lock engagement
- Cab actuated twistlocks
- Optional hydraulic tailgate

Engine Gross Power

242 kW	325 hp
--------	--------

Engine Net Power (ISO)

239 kW	321 hp
--------	--------

Operating Weight (loaded)

50 970 kg	112,370 lb
-----------	------------

Rated Payload

28.1 tonne	31.0 tons
------------	-----------

The Hydex CC30 is supplied by **Articulated Truck Solutions LLP**

CC30 Container Carrier Articulated Truck *Specifications*

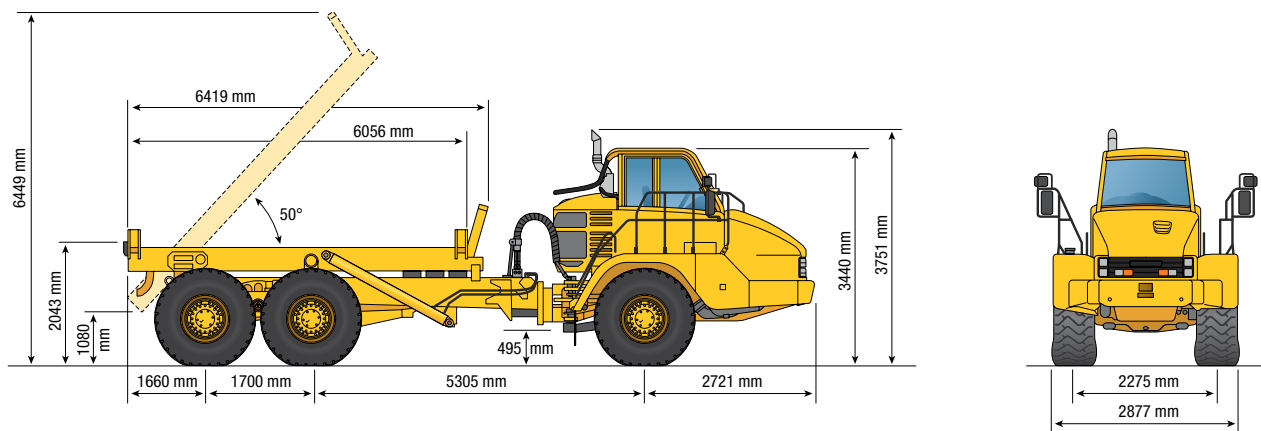

Engine

Engine Model	Cat® C11ACERT®	
Gross Power – SAE J1995	242 kW	325 hp
Net Power – SAE J1349	237 kW	317 hp
Net Power – ISO 9249	239 kW	321 hp
Net Power – EEC 80/1269	239 kW	321 hp
Bore	130 mm	5.1 in
Stroke	140 mm	5.5 in
Displacement	11.15 ltr	680 cu.in

Transmission

Forward 1	8 km/h	5 mph
Forward 2	15 km/h	9 mph
Forward 3	22 km/h	14 mph
Forward 4	34 km/h	21 mph
Forward 5	47 km/h	29 mph
Forward 6	55 km/h	34 mph
Reverse 1	9 km/h	5 mph

Standards

Brakes	ISO 3450 : 1996
Cab/FOPS	ISO 3449 Level II : 2005
Cab/ROPS	ISO 3471 : 2008
Steering	ISO 5010 : 2007

Operating Weights

Front Axle - Empty	13 140 kg	28,969 lb
Center Axle - Empty	5000 kg	11,023 lb
Rear Axle - Empty	4710 kg	10,384 lb
<i>Total Empty</i>	<i>22 850 kg</i>	<i>50,376 lb</i>
Front Axle - Rated Load	2720 kg	5997 lb
Center Axle - Rated Load	12 700 kg	27,999 lb
Rear Axle - Rated Load	12 700 kg	27,999 lb
<i>Total Rated Load</i>	<i>28 120 kg</i>	<i>61,994 lb</i>
Front Axle - Loaded	15 860 kg	34,965 lb
Center Axle - Loaded	17 700 kg	39,022 lb
Rear Axle - Loaded	17 410 kg	38,382 lb
<i>Total - Loaded</i>	<i>50 970 kg</i>	<i>112,370 lb</i>
Rated Payload	28.1 tonnes	31 tons

Body Hoist

Raise Time	12 seconds
Lower Time	8 seconds

Service Capacities

Fuel Tank	532 ltr	140.5 gal
Cooling System	80 ltr	21.1 gal
Hydraulic System	328 ltr	86.6 gal
Engine Crankcase	38 ltr	9.5 gal
Transmission	72 ltr	19 gal
Final Drives/Differential	72 ltr	19 gal
Output Transfer Gearbox	18 ltr	4.8 gal

Sound Levels

Interior Cab	79 dB(A)
--------------	----------

All cab/chassis machine specifications are contained in the Cat 730 specalogue publication AEHQ6046

Materials and specifications are subject to change without notice.

See your Caterpillar dealer for standard and optional cab equipment.

Articulated Truck Solutions LLP

Head Office

Unit 30, Twyford Business Centre
London Road, Bishop's Stortford
Herts, CM23 3YT
United Kingdom
Tel: +44 (0)1279 755590
Fax: +44 (0)1279 652644
www.hydexuk.com

CAT, CATERPILLAR, ACERT, their respective logos, "Caterpillar Yellow" and the POWER EDGE trade dress, as well as corporate and product identity used herein, are trademarks of Caterpillar and may not be used without permission.