

CC35

Hydex

Container Carrier Articulated Truck

The **HYDEX CC35** is designed for hauling 20ft ISO Containers.

Based on the Cat 735 Articulated Truck chassis offering proven reliability and durability, and high class performance and productivity, optimum payload, operator comfort and ease of operation.



- Headboard for container frame
- Safety interlock
- Container corner guards
- Cab actuated twistlocks
- Light in cab to confirm lock engagement
- Optional hydraulic tailgate

Engine Gross Power

324 kW 435 hp

Engine Net Power (ISO)

319 kW 424 hp

Operating Weight (loaded)

62 470 kg 137,400 lb

Rated Payload

32.7 tonne 36 tons

The Hydex CC35 is supplied by **Articulated Truck Solutions LLP**

CC35 Container Carrier Articulated Truck *Specifications*

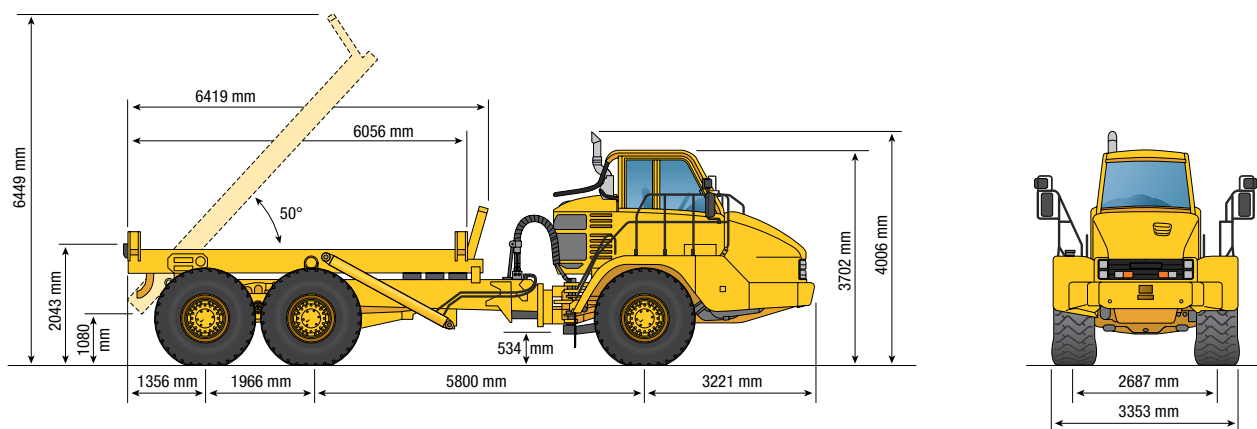

Engine

Engine Model	Cat® C15 ACERT®	
Gross Power – SAE J1995	324 kW	435 hp
Net Power – SAE J1349	313 kW	419 hp
Net Power – ISO 9249	319 kW	424 hp
Net Power – EEC 80/1269	319 kW	424 hp
Bore	137 mm	5.4 in
Stroke	171.5 mm	6.75 in
Displacement	15.2 ltr	926 cu.in

Transmission

Forward 1	8 km/h	5 mph
Forward 2	11 km/h	7 mph
Forward 3	15 km/h	10 mph
Forward 4	21 km/h	13 mph
Forward 5	28 km/h	17 mph
Forward 6	38 km/h	23 mph
Forward 7	51 km/h	32 mph
Reverse 1	8 km/h	5 mph
Reverse 2	11 km/h	7 mph

Standards

Brakes	ISO 3450 : 1996
Cab/FOPS	ISO 3449 Level II : 2005
Cab/ROPS	ISO 3471 : 2008
Steering	ISO 5010 : 2007

Operating Weights

Front Axle - Empty	18 300 kg	40,300 lb
Center Axle - Empty	6200 kg	13,600 lb
Rear Axle - Empty	5600 kg	12,300 lb
<i>Total Empty</i>	<i>30 100 kg</i>	<i>66,200 lb</i>
Front Axle - Rated Load	3300 kg	7200 lb
Center Axle - Rated Load	14 570 kg	32,100 lb
Rear Axle - Rated Load	14 570 kg	32,100 lb
<i>Total Rated Load</i>	<i>32 370 kg</i>	<i>71,200 lb</i>
Front Axle - Loaded	21 600 kg	47,500 lb
Center Axle - Loaded	20 770 kg	45,700 lb
Rear Axle - Loaded	20 100 kg	44,200 lb
<i>Total - Loaded</i>	<i>62 470 kg</i>	<i>137,400 lb</i>
Rated Payload	32.7 tonnes	36 tons

Body Hoist

Raise Time	10 seconds
Lower Time	6 seconds

Service Capacities

Fuel Tank	532 ltr	140.5 gal
Cooling System	80 ltr	21.1 gal
Hydraulic System	328 ltr	86.6 gal
Engine Crankcase	38 ltr	9.5 gal
Transmission	72 ltr	19 gal
Final Drives/Differential	72 ltr	19 gal
Output Transfer Gearbox	18 ltr	4.8 gal

Sound Levels

Interior Cab	79 dB(A)
--------------	----------

All cab/chassis machine specifications are contained in the Cat 735 specalogue publication AEHQ6049

Materials and specifications are subject to change without notice.

See your Caterpillar dealer for standard and optional cab equipment.

Articulated Truck Solutions LLP

Head Office

Unit 30, Twyford Business Centre
London Road, Bishop's Stortford
Herts, CM23 3YT
United Kingdom
Tel: +44 (0)1279 755590
Fax: +44 (0)1279 652644
www.hydexuk.com

CAT, CATERPILLAR, ACERT, their respective logos, "Caterpillar Yellow" and the POWER EDGE trade dress, as well as corporate and product identity used herein, are trademarks of Caterpillar and may not be used without permission.