

HL23

Hydex

Hook Lift Articulated Truck

The Hydex HL23 is designed for loading, unloading and tipping a range of containers and bodies. Based on the Cat 725 Articulated Truck, the Hydex HL23 offers proven reliability and durability, high performance, low fuel consumption, operator comfort and low operating costs.

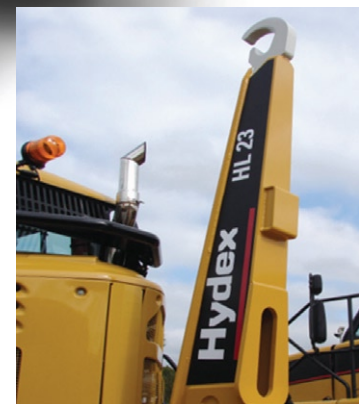

Engine Gross Power

230 kW

309 hp

Engine Net Power (ISO)

227 kW

304 hp

Operating Weight (loaded)

45 850 kg

101 085 lb

Rated Payload

23.6 tonne

26 tons

The Hydex HL23 is manufactured and supplied by **Articulated Truck Solutions LLP**

HL23 Hook Lift Articulated Truck *Specifications*

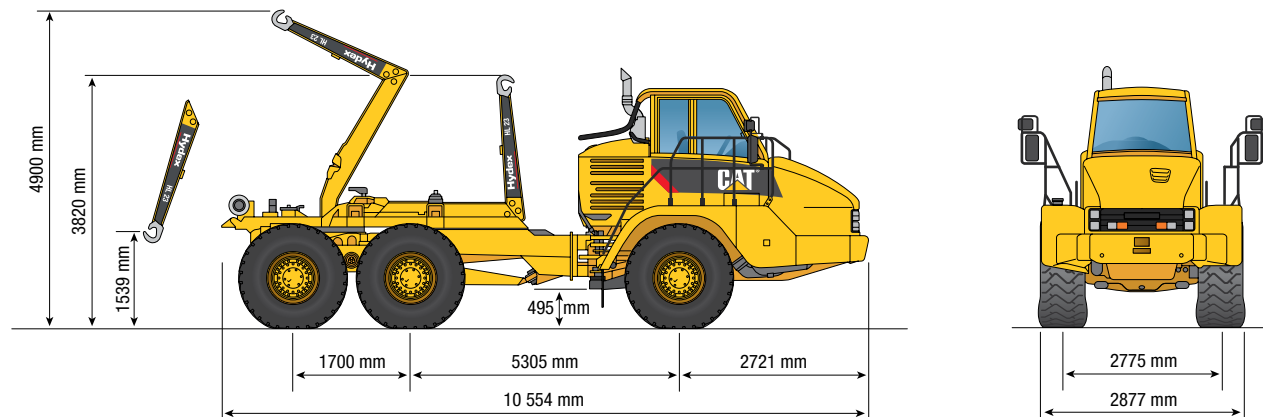

Engine

Engine Model	Cat® C11 ACERT®	
Gross Power – SAE J1995	230 kW	309 hp
Net Power – SAE J1349	225 kW	301 hp
Net Power – ISO 9249	227 kW	304 hp
Net Power – EEC 80/1269	227 kW	304 hp
Bore	130 mm	5.1 in
Stroke	140 mm	5.5 in
Displacement	11.15 ltr	680 cu.in

Transmission

Forward 1	8 km/h	5 mph
Forward 2	15 km/h	9 mph
Forward 3	23 km/h	14 mph
Forward 4	35 km/h	21 mph
Forward 5	48 km/h	30 mph
Forward 6	57 km/h	35 mph
Reverse 1	8 km/h	5 mph

Standards

Brakes	ISO 3450 : 1996
Cab/FOPS	ISO 3449 Level II : 2005
Cab/ROPS	ISO 3471 : 2008
Steering	ISO 5010 : 2007

Operating Weights

Front Axle - Empty	13 020 kg	28,705 lb
Center Axle - Empty	4830 kg	10,650 lb
Rear Axle - Empty	4410 kg	9,720 lb
<i>Total Empty</i>	<i>22 260 kg</i>	<i>49,075 lb</i>
Front Axle - Rated Load	2010 kg	4430 lb
Center Axle - Rated Load	10 790 kg	23,790 lb
Rear Axle - Rated Load	10 790 kg	23,790 lb
<i>Total Rated Load</i>	<i>23 590 kg</i>	<i>52,010 lb</i>
Front Axle - Loaded	15 030 kg	33,135 lb
Center Axle - Loaded	15 620 kg	34,440 lb
Rear Axle - Loaded	15 200 kg	33,510 lb
<i>Total - Loaded</i>	<i>45 850 kg</i>	<i>101,085 lb</i>
Rated Payload	23.6 tonnes	26 tons

Service Capacities

Fuel Tank	355 ltr	94 gal
Cooling System	67 ltr	18 gal
Hydraulic System	151 ltr	49 gal
Engine Crankcase	41 ltr	11 gal
Transmission	36 ltr	9.5 gal
Final Drives	164 ltr	43.3 gal
Output Transfer Gearbox	18 ltr	4.8 gal

Sound Levels

Interior Cab	76 dB(A)
--------------	----------

All cab/chassis machine specifications are contained in the Cat 725 specalogue publication AEHQ5647

Materials and specifications are subject to change without notice.

See your Caterpillar dealer for standard and optional cab equipment.

Articulated Truck Solutions LLP

Head Office

Unit 30, Twyford Business Centre
London Road, Bishop's Stortford
Herts, CM23 3YT
United Kingdom
Tel: +44 (0)1279 755590
Fax: +44 (0)1279 652644
www.hydexuk.com

CAT, CATERPILLAR, ACERT, their respective logos, "Caterpillar Yellow" and the POWER EDGE trade dress, as well as corporate and product identity used herein, are trademarks of Caterpillar and may not be used without permission.