

## E-Ject™ Systems 7460 Ejector Trailer



The E-Ject™ Systems 7460 Ejector Trailer expands the capacity of the Cat® 740 Articulated Truck by 40% — move more dirt faster with fewer operators and machines.

### Feature Highlights

- Top-load with a Cat hydraulic excavator or wheel loader.
- Expands the haul capacity of the Cat 740 Articulated Truck by 40% per cycle – reduces the number of trips required on jobsites with long haul distances.
- Uses wheel tractor scraper-type ejection system to distribute the material in a uniform lift, while reducing the need for support machines to spread the material.
- Shortens cycle times because the trailer ejects the material on the go, eliminating the need to stop, back up, dump the load, and return the dump bed to the travel position.
- The trailer's walking-beam suspension provides a smoother ride, greater operator comfort, less haul road pumping.
- Even distribution of weight over five axles reduces ground pressure from standard 740 Articulated Trucks by 12% in soft soils.
- High-strength, abrasion-resistant steel is used on the body floor, sides, apron, and ejector face for maximum strength and wear life.
- Each trailer wheel is equipped with two heavy-duty, dry-disc brake calipers to ensure effective stopping from safe operating speeds.

# Expand Your Capacity.



**Higher Capacity.** With 40% higher capacity than a standard Cat® 740 Articulated Truck, the E-Ject™ 7460 Ejector Trailer provides increased productivity at lower costs. The trailer, which connects to a fifth-wheel style hitch installed in place of the truck body, is pulled by rugged and powerful Cat 740 Articulated Trucks.

**Broad Material Appetite.** The 7460 Ejector Trailer is an exceptional hauling solution for moving sand, gravel, top soil, or rock up to 61 cm (24 in) in diameter on jobsites with extended haul distances and grades of 8% or less. The 7460 is ideally suited to be top-loaded by the Cat 385CL Hydraulic Excavator or Cat 980H Wheel Loader.

**Unload with Less Support Equipment.** The 7460 Ejector trailer uses a wheel tractor scraper-type ejection system to unload material on the go, eliminating the need to stop, back up, dump the load, and return to the travel position. The ejector distributes the material in a uniform lift, reducing the need for additional support machines to spread the material.

**Performance in Poor Underfoot Conditions.** The 7460 Ejector Trailer provides outstanding performance in all types of ground conditions, including soft soil conditions. Because it distributes the weight over five axles, instead of three, the 7460 Ejector Trailer exerts 12% less ground pressure than a standard 740 Articulated Truck.

On uneven terrain, the walking-beam axles allow the standard radial tires to oscillate, providing greater operator comfort and less haul road pumping.

**Built for Durability.** The body on the 7460 Ejector Trailer is built for durability. The body walls use a cellular construction for strength and dent resistance. The inner walls, floor, apron face, and ejector are made from high-strength, abrasion-resistant steel for long life in all material types.

Hydraulic and brake circuits are carried to the rear of the trailer through steel lines enclosed in the body walls, protecting them from damage during loading.



# Maximize Your Investment.

## Trailer Body



The 7460 Ejector Trailer unloads quickly, due in part to the 1281 mm (78 in) apron opening. The positive bulldozer ejector extends 102 mm (4 in) beyond the front edge of the trailer floor to minimize carryback.

For increased service life, the weight of the ejector is supported by rollers on wear strips welded to the body floor. At the sides, ejector alignment is maintained by Ultra High Molecular Weight (UHMW) plastic alignment guides, eliminating steel-on-steel wear.

## Operator Controls



The 7460 Ejector Trailer is easy to operate. A dual-mode (Manual and Automatic), in-cab controller is used to control the trailer's apron and ejector functions.

In Automatic mode, the operator can raise the apron, eject the material, lower the apron, and retract the ejector cylinder at the push of a button. An integrated load counter makes tracking production easier. In Manual mode, the operator has complete manual control of trailer functions.

## Hitch



The 7460 Ejector Trailer connects to Cat 740 Articulated Trucks using a 89 mm (3.5 in) diameter pin in a fifth-wheel style hitch installed in place of the truck body and hoist mechanisms. The hitch position is centered between the truck's rear axles for optimal weight distribution when loaded.

With a turning radius of just 12.3 m (40.5 ft), the hitch allows the truck / trailer to turn in narrow conditions such as found in road construction applications.

The hitch can be installed on new 740 Articulated Trucks or existing fleets can be converted.

## Axles, Tires, and Brakes



The innovative walking-beam axles allow the tires to oscillate, providing outstanding operator comfort and less haul road pumping.

All 7460 Ejector Trailers are equipped with standard radial tires for heat- and cut-resistance.

Standard dual-caliper, dry-disc brakes provide effective stopping power from safe operating speeds. For easy operation, the trailer brake system is integrated into the truck's brake system for single pedal actuation.

## Dimensions

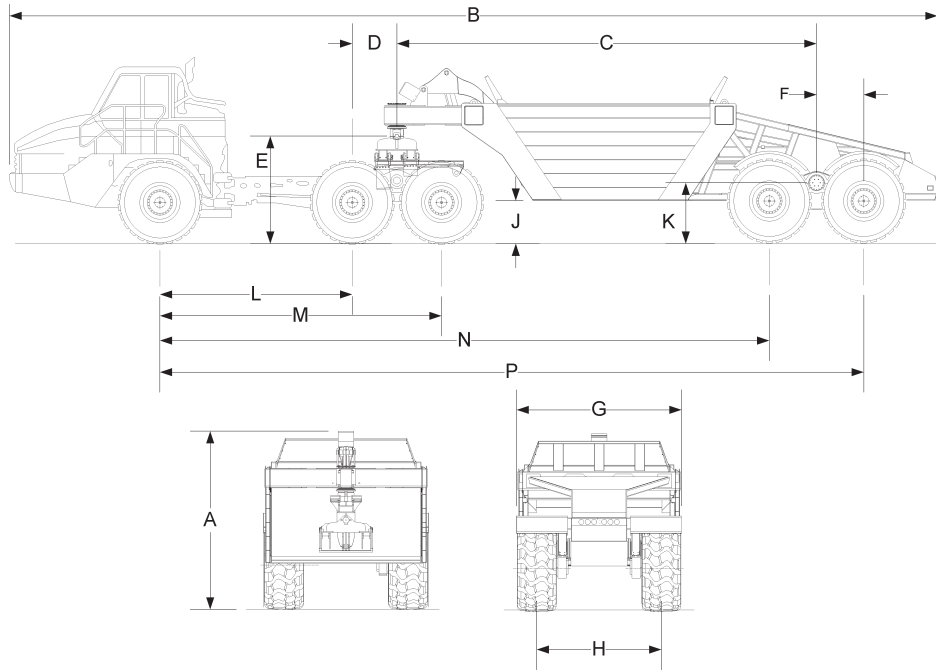

A	386.1 cm / 12 ft 8 in	H	274.6 cm / 9 ft 0 in
B	2045 cm / 67 ft 1 in	J	94.7 cm / 3 ft 1 in
C	924.6 cm / 11 ft 1 in	K	134.1 cm / 4 ft 5 in
D	98.3 cm / 2 ft 3 in	L	423.7 cm / 14 ft 1 in
E	237.0 cm / 7 ft 9 in	M	621.8 cm / 20 ft 5 in
F	103.9 cm / 3 ft 5 in	N	1342.6 cm / 44 ft 1 in
G	365.8 cm / 12 ft 0 in	P	1550.4 cm / 50 ft 10 in

## Specifications

### Trailer Specifications

Heaped Capacity	35.9 m <sup>3</sup> / 46.9 yd <sup>3</sup>
Struck Capacity	27.9 m <sup>3</sup> / 36.5 yd <sup>3</sup>
Empty Weight	24040 kg / 53000 lb
Tires - Standard	29.5 R 25
Tire - Optional	875 65R29

### Truck and Trailer Specifications

Loaded Gross Weight	105886 kg / 233440 lb
Payload	54431 kg / 120000 lb
Total Capacity	35.9 m <sup>3</sup> / 46.9 yd <sup>3</sup>

### Ground Pressure at Rated Load<sup>1</sup>

Truck Front Axle	1.7 kg/cm <sup>2</sup> (23.6 PSI)
Truck Center Axle	1.7 kg/cm <sup>2</sup> (23.9 PSI)
Truck Rear Axle	1.7 kg/cm <sup>2</sup> (24.7 PSI)
Trailer Front Axle	1.8 kg/cm <sup>2</sup> (25.9 PSI)
Trailer Rear Axle	1.8 kg/cm <sup>2</sup> (25.5 PSI)

<sup>1</sup> Ground pressure at 76 mm (3 in) tire penetration.

### Empty Weights - Truck and Trailer

Truck Front Axle	19178 kg / 42280 lb
Truck Center Axle	8010 kg / 17660 lb
Truck Rear Axle	7856 kg / 17320 lb
Trailer Front Axle	8337 kg / 18380 lb
Trailer Rear Axle	8074 kg / 17800 lb

### Loaded Weights - Truck and Trailer

Truck Front Axle	20179 kg / 44487 lb
Truck Center Axle	20497 kg / 45188 lb
Truck Rear Axle	21142 kg / 46610 lb
Trailer Front Axle	22198 kg / 48938 lb
Trailer Rear Axle	21870 kg / 48217 lb

Materials and specifications are subject to change without notice. Equipment availability may be limited to a specific regional area. Featured machines in photos may include additional equipment. CAT, CATERPILLAR, E-JECT, their respective logos, "Caterpillar Yellow," and the "POWER EDGE" trade dress, as well as all corporate and product identity used herein, are trademarks of Caterpillar and may not be used without permission.