



MAGNUM™ MTT7 / CAT® D35

7,000 GALLON WATER TANK

Quality, performance and value you expect from the leader in the haulage equipment and water tank industry.



Optional Equipment May Be Shown

Quality Through Comprehensive Design

MEGA CORP.®

700 Osuna Rd. NE • P.O. Box 26146 • Albuquerque, NM 87113

(505) 345-2661 • Fax (505) 345-6190 • www.megacorpinc.com

Manufacturers of Construction and Mining Equipment

MTT7_D35_Rev05



STANDARD EQUIPMENT INCLUDES:

- Magnum® Anti-Surge Stabilization Tube (M.A.S.T.).
- Rear spray bar with four (4) **patented** spray head valves.
- Externally mounted hydraulic driven 850 GPM@50 PSI water pump.
- Electric control console for individual operation of each spray head.
- Low profile dual radius elliptical tank design.
- Three (3) reinforced transverse baffles with banded (reinforced) access ports.
- 30 inch diameter fill port with trash screen and safety grate.
- Access ladder.
- Anti-skid (perforated metal) walkway from access ladder to fill port.
- Safety railings on top of tank.
- Running, tail and stop lights.
- Rust inhibitor coating on bottom quadrant of tank interior.
- Tank exterior sandblasted, primed and painted to customer specified color.
- Drive tire fenders with mud flaps mounted at the rear of fender.

OPTIONAL EQUIPMENT AVAILABLE:

- High performance water pump 1500 GPM@100 PSI
- Two (2) additional spray heads mounted on the front quadrant with individual cab controls for vertical side spray.
- Hose reels:
 - (A) 50 feet (15.24 m) of 1 inch (25.4 mm) or 1.5 inch (38.1 mm) with adjustable nozzle.
 - (B) 100 feet (30.48 m) of 1 inch (25.4 mm) or 1.5 inch (38.1 mm) with adjustable nozzle.
- Intermittent spray package – automatic system for alternate wet strip/dry strip watering of haul road for extended range and safety.
- Water level gauge in operator compartment.
- Sight gauge type water level indicator.
- Complete interior of tank sandblasted and coated with amine cure epoxy.
- 3 inch (76.2 mm) ground level fill.
- Suction loading system – Utilizes a hydraulically driven 4" inlet/outlet suction pump capable of loading unit at approximately 550 GPM.
- Foam injection (fire fighting) system.
- Additional paint schemes to customer specifications.
- Customized options available upon request.

Patent # 4167247



Magnum™ Spray Head



Patent # 4251005

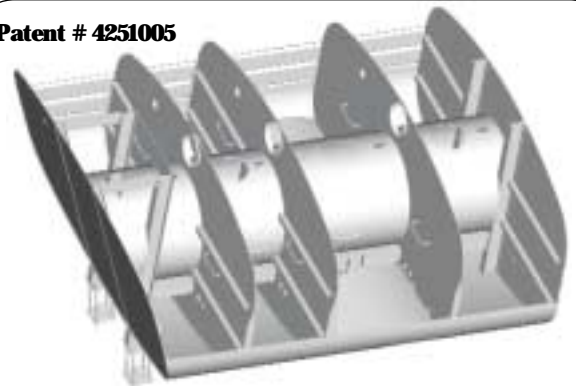

Magnum™ Anti-Surge Stabilization Tube (M.A.S.T.)