



MTT6 / CAT® D250E EXTENDED FRAME

MAGNUM™ 6,000 GALLON WATER TANKER

Quality, performance and value you expect from the leader in the haulage equipment and water tank industry.

Magnum™ Tank features include:

- Magnum™ Anti-Surge Stabilization Tube (M.A.S.T.), **patented**, for increased stability in turns and uneven terrain. Design adds additional structural integrity to the tank.
- Magnum™ Spray Head Valves, **patented** design offers infinitely variable spray patterns with even distribution and easy adjustment.
- Access ladder with handrails, non-skid walkways, and banded manhole with safety grate.
- Advanced water pump design with self aligning direct mounted hydraulic motor.
- Formed ribs in bulkhead, transverse baffles and side panels for superior strength.
- Unique “T” flange reinforcement between the tank shell and the transverse baffles.
- Unmatched parts and service support through your local dealer.



Photos may show optional equipment

Quality Through Comprehensive Design

MEGA CORP.®

700 Osuna Rd. NE • P.O. Box 26146 • Albuquerque, NM 87113

(505) 345-2661 • Fax (505) 345-6190 • www.megacorpinc.com

Manufacturers of Construction and Mining Equipment



MTT6 / CAT® D250E EXTENDED FRAME

STANDARD EQUIPMENT INCLUDES:

- Magnum™ Anti-Surge Stabilization Tube (M.A.S.T.).
- Rear spray bar with four (4) **patented** spray head valves.
- Externally mounted hydraulic driven 850 GPM@50 PSI water pump.
- Electric control console for individual operation of each spray head.
- Low profile dual radius elliptical tank design.
- Three (3) reinforced transverse baffles with banded (reinforced) access ports.
- 30 inch diameter fill port with trash screen and safety grate.
- Access ladder.
- Anti-skid (perforated metal) walkway from access ladder to fill port.
- Safety railings on top of tank.
- Running, tail and stop lights.
- Rust inhibitor coating on bottom quadrant of tank interior.
- Tank exterior sandblasted, primed and painted to customer specified color.
- Drive tire fenders with mud flaps mounted at the rear of fender.

OPTIONAL EQUIPMENT AVAILABLE:

- High performance water pump 1500 GPM@100 PSI
- Monitor (water cannon) with in-cab control (tank or tractor mounted available.)
- Two (2) additional spray heads mounted on the front quadrant of tank with individual cab controls for vertical side spray.
- Hose reels:
 - (A) 50 feet (15.24 m) of 1 inch (25.4 mm) or 1.5 inch (38.1 mm) with adjustable nozzle.
 - (B) 100 feet (30.48 m) of 1 inch (25.4 mm) or 1.5 inch (38.1 mm) with adjustable nozzle.
- Intermittent spray package – automatic system for alternate wet strip/dry strip watering of haul road for extended range and safety.
- Water level gauge in operator compartment.
- Sight gauge type water level indicator.
- Complete interior of tank sandblasted and coated with amine cure epoxy.
- 3 inch (76.2 mm) ground level fill.
- Suction loading system – Utilizes a hydraulically driven 4" inlet/outlet suction pump capable of loading unit at approximately 550 GPM.
- Foam injection (fire fighting) system.
- Additional paint schemes to customer specifications.
- Customized options available upon request.

Patent #4167247



Patented Magnum™ Spray Head

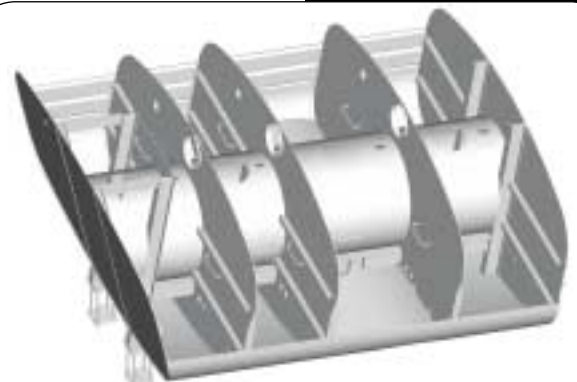

Patented Magnum™ Anti-Surge Stabilization Tube (M.A.S.T.)

Specifications and options subject to change