

STANDARD EQUIPMENT

ENGINE

- Engine, MITSUBISHI D04EG-TAA engine with turbocharger and intercooler
- Automatic engine deceleration
- Batteries (2 x12V – 80 Ah)
- Starting motor (24 V- 5 kW), 50 A alternator
- Automatic engine shut-down for low engine oil pressure
- Engine oil pan drain valve
- Double element air cleaner

CONTROL

- Working mode selector (H-mode, S-mode and ECO-mode)

SWING SYSTEM & TRAVEL SYSTEM

- Swing rebound prevention system
- Straight propel system
- Two-speed travel with automatic shift down
- Sealed & lubricated track links
- Grease-type track adjusters
- Automatic swing brake

MIRRORS & LIGHTS

- Three rear view mirrors
- Three front working lights
- Rear view camera

CAB & CONTROL

- Two control levers, pilot-operated
- Horn, electric
- Integrated left-right slide-type control box
- Cab light (interior)
- Coat hook
- Luggage tray
- Large cup holder
- Detachable two-piece floor mat
- 7-way adjustable suspension seat
- Retractable seatbelt
- Headrest
- Handrails
- Heater and defroster
- Intermittent windshield wiper with double-spray washer
- Tinted safety glass
- Pull-type front window and removable lower front window
- Easy-to-read multi-display monitor
- Automatic air conditioner
- Emergency escape hammer
- Radio, AM/FM Stereo with speaker
- Gear pump
- Refueling pump
- Pressure release switch
- DRF switch

OPTIONAL EQUIPMENT

- | | |
|--|---|
| <ul style="list-style-type: none"> ■ Wide range of bucket ■ Various optional arms ■ Wide range of shoes ■ Boom safety valve ■ Front-guard protective structure (may interfere with bucket action) ■ Object Handling Kit (boom safety + hook) | <ul style="list-style-type: none"> ■ Additional hydraulic circuit ■ Extra piping ■ Add-on type counterweight ■ Cab additional light ■ Air suspension seat ■ Rain visor (may interfere with bucket action) |
|--|---|

Note: standard and optional equipment may vary. Consult your KOBELCO dealer for specifics.

Note: This catalog may contain attachments and optional equipment that are not available in your area. And it may contain photographs of machines with specifications that differ from those of machines sold in your areas. Please consult your nearest KOBELCO distributor for those items you require. Specialist equipment is needed to use this machine in demolition work. Before using it please contact your KOBELCO dealer. Due to our policy of continuous product improvements all designs and specifications are subject to change without advance notice. Copyright by **KOBELCO CONSTRUCTION MACHINERY CO., LTD.** No part of this catalog may be reproduced in any manner without notice.

KOBELCO CONSTRUCTION MACHINERY CO., LTD.

17-1, Higashigotanda 2-chome, Shinagawa-ku, Tokyo 141-8626 JAPAN
Tel: +81 (0) 3-5789-2146 Fax: +81 (0) 3-5789-2135
www.kobelco-kenki.co.jp/english_index.html

Inquiries To:

SK140SR_{LC}-EU-101-130303IF

SK140SR_{LC}



- Bucket Capacity:
0.24 – 0.7 m³ ISO heaped
- Engine Power:
74 kW /2,000 min⁻¹(ISO14396)
- Operating Weight:
14,400 kg

Complies with the latest exhaust emission regulations



US
EPA Tier IV



EU (NRMM)
Stage IIIB



Japanese
Regulations

We Save You Fuel
Achieving a Low-Carbon Society

Powerful, Agile and Quiet.

New performance Capacities with a Small Rear Swing

The rounded form says it all: an excavator built with a tiny rear swing for maximum maneuverability. But KOBELCO has taken this concept one step further by seeing just how much digging performance can be packed into a machine. It is not the compact design that matters so much as the performance and functions that are actually used on site. And that's just where the new SR Series really shines, thanks to our NEXT-3E concept. Thanks to key iNDr technology, we've realized a whole new level of quiet operation, backed by a next-generation power plant that pushes performance to extraordinary new heights. Ten years after developing groundbreaking machines with tiny rear swings, KOBELCO continues to forge ahead as the leader in the field.

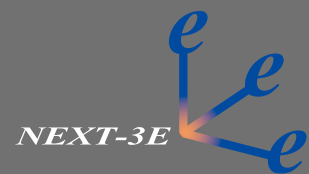

Pursuing the "Three E's"

The Perfection of Next-Generation,
Network Performance

Enhancement

Greater Performance Capacity

Economy

Improved Cost Efficiency

Environment

Features That Go Easy on the Earth



Amazingly Quiet!

Effective Dust Protection!

**Remarkable Ease of
Maintenance!**



Image illustrates iNDr system

The iNDr Revolution

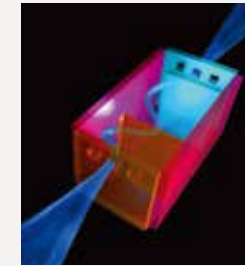

•Concept

KOBELCO has developed the revolutionary integrated Noise and Dust Reduction Cooling System, with the engine compartment placed inside a single duct that connects the air intake to the exhaust outlet.



•Reduces Noise

The intake and exhaust are offset, with the holes and joints in the sections corresponding to the duct wall completely covered to reduce noise at the intake and exhaust apertures. This design, plus the generous use of insulation-material inside the duct, minimizes engine noise.



•Reduces Dust

The high-performance iNDr filter removes dust from intake air, ensuring a quieter, cleaner engine and keeping the cooling unit free of clogging so that no regular cleaning is necessary.

iNDr Filter

Far Surpassing Legal Requirements

The SR series has broken through to a new frontier in quiet operation, with a noise level a full 5 dB below the Japanese government's requirements for ultra-low-noise machinery. In fact, compared with previous KOBELCO models, we have achieved a 10 dB reduction on the right-side surface of the machine, a difference that is clearly audible.



**"Ultimate"-Low Noise Level of
95dB(A)**

More Work with Less Fuel!

Fuel Consumption and Work Volume

The new hydraulic system and an additional ECO-mode have cut fuel consumption by up to 22%.

H-mode (vs previous SK135SRLC in H-mode)

Fuel consumption (L/h)

8 % decrease

Work volume per liter of fuel (m³/L)

10 % increase

S-mode (vs previous SK135SRLC in H-mode)

Fuel consumption (L/h)

16 % decrease

Work volume per liter of fuel (m³/L)

19 % increase

ECO-mode (vs previous SK135SRLC in S-mode)

Great leap forward in energy-saving performance

Fuel consumption (L/h)

22 % decrease

Work volume per liter of fuel (m³/L)

19 % increase

*Figures for fuel consumption: fuel consumed per hour (L/h) compared with previous model, in KOBELCO tests.

*Figures for work volume: digging volume per liter of fuel (m³/L) compared with previous model, in KOBELCO tests.

Significant Extension of Continuous Working Hours

The combination of a large-capacity fuel tank and excellent fuel efficiency delivers an impressive max. 19% increase in continuous operation hours.*

Fuel tank: **200 L**

ECO-mode

Work modes for a closer match to the job in hand. An addition to the existing H-mode and S-mode, the new ECO-mode saves even more energy.

H
S
E



H-mode: For heavy duty when a higher performance level is required.

S-mode: For normal operations with lower fuel consumption.

ECO-mode: Puts priority on low fuel consumption and economic performance.



NEXT-3E Technology New Hydraulic System

Rigorous inspections for pressure loss are performed on all components of the hydraulic piping, from the spool of control valve to the connectors. This regimen, combine with the use of a new, high-efficiency pump, cuts energy loss to a minimum.



NEXT-3E Technology Total Tuning Through Advanced ITCS Control

The next-generation engine control is governed by a new version of ITCS, which responds quickly to sudden changes in hydraulic load to ensure that the engine runs as efficiently as possible with a minimum of wasted output.

ITCS (Intelligent total Control System) is an advanced, computerized system that provides comprehensive control of all machine functions.

NEXT-3E Technology Next-Generation Electronic Engine Control

The new electronic-control common-rail engine features high-pressure fuel injection and multiple injection with improved precision. It is fitted with an EGR cooler, and DP filter which deliver high output from optimized combustion and greatly reduce PM and NOx emissions



Tier 4-compliant engine

PM emissions cut: Limits creation of particulate matter (which results from incomplete combustion of fuel)

Common rail system

High-pressure injection atomizes the fuel, and injection timing is more precise, improving combustion efficiency.

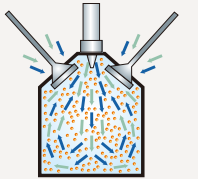

DP filter

Carbon builds up as soot on the diesel particulate filter and is burned off at high temperature. At low engine speeds the exhaust temperature is too low, and the common rail multiple injection system is then used to raise the temperature sufficiently to burn off the soot.



Platinum catalyzer Filter

NOx emissions cut: Reduces nitrous oxides (created by reaction with oxygen at high temperature)

EGR cooler

While ensuring sufficient oxygen for combustion, cooled emission gases are mixed with the air intake and re-circulated into the engine. The lowered oxygen temperature lowers the combustion temperature and increases combustion efficiency.

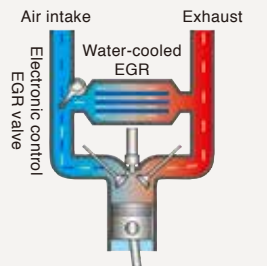

Automatic Acceleration/Deceleration Function Reduces Engine Speed

Engine speed is automatically reduced when the control lever is placed in neutral, effectively saving fuel and reducing noise and exhaust emissions. The engine quickly returns to the previous speed when the lever is moved out of neutral.

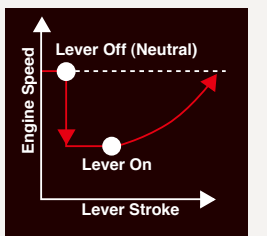

Efficient Performance!

“Top-Class” Powerful Digging

Max. arm crowding force: **64.4 kN** {6.57 tf}

Max. bucket digging force: **90.1 kN** {9.19 tf}

Powerful Travel

Travel torque: increase by **9 %** ↑

Drawbar pulling force: **138 kN** {14.1 tf}

Optional N&B (crusher and breaker)

The operator selects the desired mode from inside the cab, and the selector valve automatically configures the machine accordingly.

Attachment Mode Selector Switch

There's a choice of three different hydraulic circuits, to accommodate bucket, crusher or breaker, and the desired attachment mode can be selected with a switch, which automatically configures the selector valve. All attachment modes can be used in S-mode, H-mode and ECO-mode.



Dramatic Increase in Maximum Dumping Height

Max. digging height: **9,190 mm**
(560 mm more than previous model)

Max. dumping height: **6,740 mm**
(540 mm more than previous model)

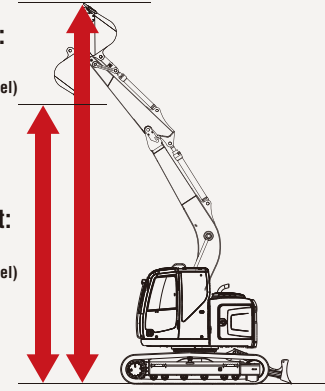

The bottom of the upper frame features single-plate construction for solid stability, combined with dramatic increases in maximum digging and dumping heights to deliver a wider working range than ever before.

*Previous model: SK135SRLC

Greater Swing Power, Shorter Cycle Times

Swing torque: increased by **5.0 %** ↑

Swing torque: **39.9 kN**

Swing Speed: **11.0 min⁻¹**

Requires 3.6 m of Working Space

The compact design allows the machine to perform continuous dig, 180° swing and dump operations within a working space of 3.6 m (with 600 mm shoe).



*Working width (180°) equals the sum of the minimum front swing radius and tail swing radius.

Mild Operating Sound

The iNdr cooling system also helps to keep the machine quiet, even at close quarters. Even the hydraulic relief valves have been designed specially to reduce irritating noise during operation.

Meets EMC (Electromagnetic Compatibility) Standards in Europe

Electrical shielding ensured that the machine is clear all European standards and neither cause or are affected by electromagnetic interference.

A Working Environment that Helps the Operator Concentrate on the Job at Hand!

Big Cab



The "Big cab" provides a roomy operating space with plenty of legroom, and the door opens wide for entry and exit. As well as giving a wide, open view to the front, the cab has increased window areas on both sides and to the rear, for improved visibility in all directions.

*Photo is the optional specs with air suspension seat.

Wide-Access Cab Aids Smooth Entry and Exit



Easy entry and exit assured with wider cab entry and safety lock lever integrated with mounting for control levers.

In-Cab Noise is Reduced by 5 dB

Compared with Previous Models

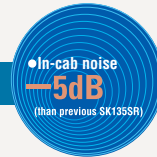

Multi-Display Color Monitor for Easy Checking

An LCD multi-display color monitor is fitted as standard. Operations data as well as the full range of machine-status data can readily be checked.



● Fuel consumption

● Maintenance

● Rearview monitoring



The photo includes optional pedals for N & B. Suspension seat not shown.

ROPS Cab



The newly developed, ROPS (Roll-Over-Protective Structure)-compliant cab clears ISO standards (ISO-12117-2: 2008) and ensures greater safety for the operator should the machine tip over.

- Level 2 FOPS Guard (ISO 10262) is available as option.
- To fit vandalism guards, please contact your KOBELCO dealer. (Mounting brackets for vandalism guards)

Safety Features That Take Various Scenarios into Consideration

- Firewall separates the pump compartment from the engine
- Handrails meet European standards
- Thermal guard prevents contact with hot components during engine inspections
- Retractable seatbelt requires no manual adjustment
- Travel alarm

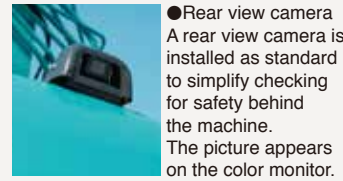

● Rear view camera
A rear view camera is installed as standard to simplify checking for safety behind the machine. The picture appears on the color monitor.



● Hammer for emergency exit

Comfortable Operating Environment



● Double slide seat

● Powerful automatic air conditioner

● Two-speaker FM/AM radio with station select

● One-touch lock release simplifies opening and closing front window

● Large cup holder

● Spacious luggage tray

Fast, Accurate and Low-Cost Maintenance

Comfortable "On the Ground" Maintenance

All of components that require regular maintenance are laid out for easy access. Newly designed, the bonnet opens widely and at lower level. And in a new layout, equipment that requires maintenance is positioned in easily accessible locations. The servicing jobs can be completed from ground or in the cab.

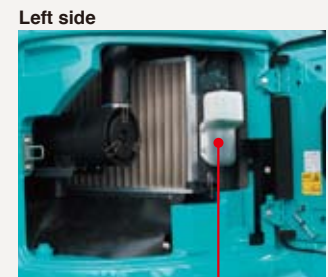

Radiator reservoir tank

● Easy access to cooling units

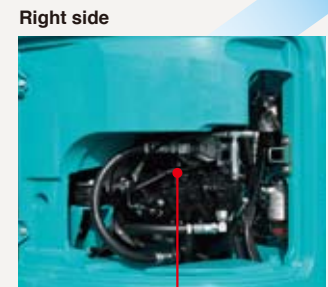

Hydraulic pump

● Easy access to pump

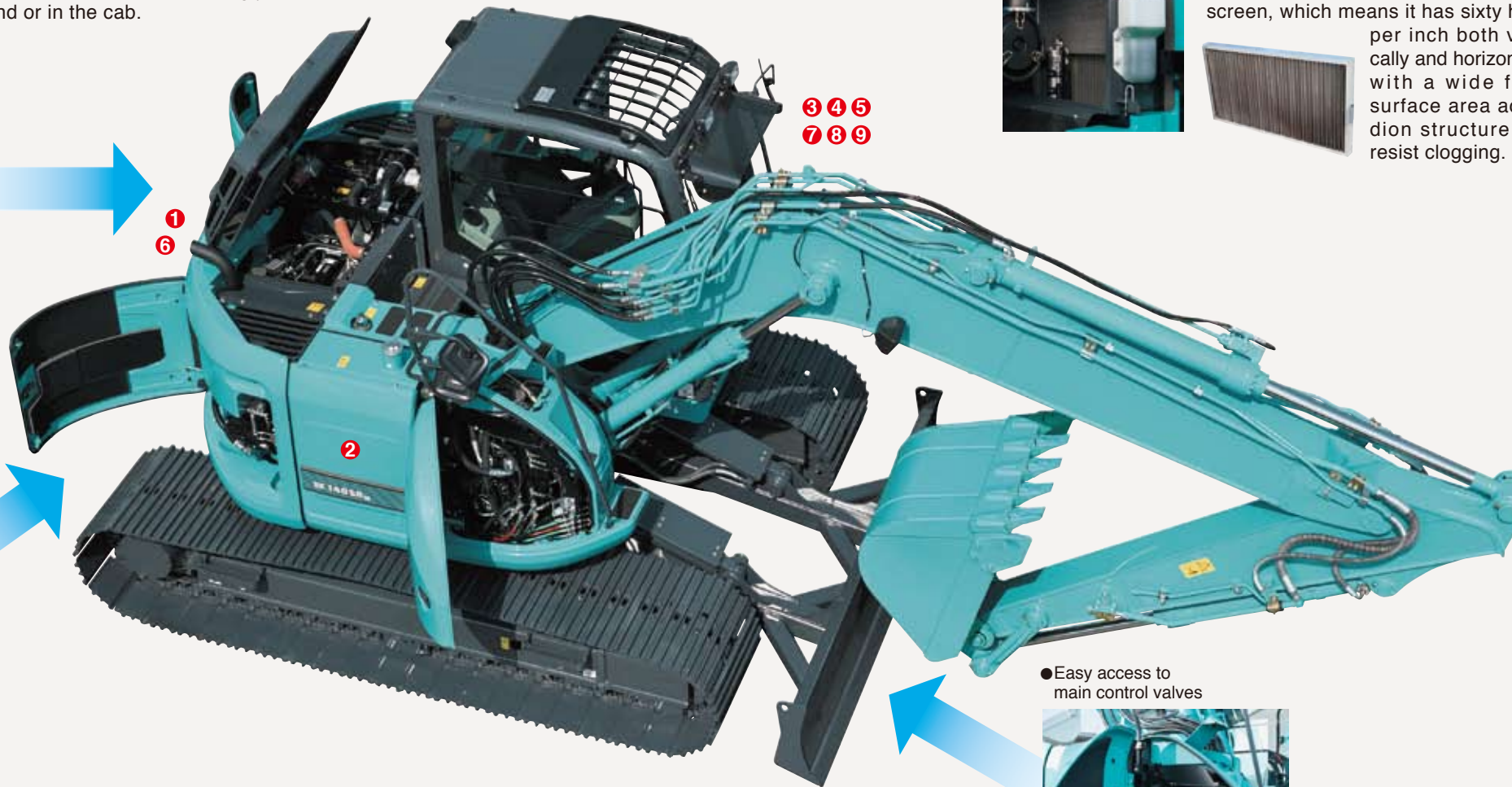

iNDr Means Easy Maintenance

iNDr Filter Blocks Out Dust



Outside air goes directly from the intake duct through the iNDr filter for dust removal. The filter features a 60-mesh screen, which means it has sixty holes per inch both vertically and horizontally, with a wide front surface area accordion structure that resist clogging.

Visual Checking and Easy Cleaning



When checking and cleaning the cooling system, one must deal with several different components like the radiator, oil cooler and intercooler, which all must be handled in different ways. But with the iNDr filter, there's just one filter in one place. If it looks dirty during start-up inspection, it can be cleaned easily and quickly.

Long-Interval Maintenance



● Long-life hydraulic oil reduces cost and labor.

Super-Fine Filter

High-performance, super-fine filter has a 1,000 hour replacement cycle.



● Super-fine filter

High-grade Fuel Filter with Superior Filtration Performance

The high-performance, large capacity filter is specially designed for a common-rail engine and features 2.9 times more filtering area than previous Filters.

Monitor Display with Essential Information for Accurate Maintenance Checks



- Displays only the maintenance information that's needed, when it's needed.
- Self-diagnostic function that provides early-warning detection and display of electrical system malfunctions.
- Record function of previous breakdowns including irregular and transient malfunction.

Fast Maintenance



● Starter easily replaced from the pump side

- Engine quick drain cock can be turned without tools.
- Fuel tank equipped with bottom flange and large drain valve.
- Hour meter can be checked while standing on the ground.
- Easy-access fuse box. More finely differentiated fuses make it easier to locate malfunctions.
- Washer fluid tank located under the cab floor mat.
- Easy replaceable engine oil filter

Easy Cleaning



- Detachable two-piece floor mat with handles for easy removal. A floor drain located under floor mat.
- Internal and external air conditioner filters can be easily removed without tools for cleaning.
- Special crawler frame designed is easily cleaned of mud.

Choice of 16 Languages for Monitoring Display

With messages including those requiring urgent action displayed in the local language, users in all parts of the world can work with greater peace of mind.



Engine

Model	MITSUBISHI D04EG-TAA
Type:	Direct injection, water-cooled, 4-cycle diesel engine With turbocharger, intercooler (Complies with EU Stage IIIB and US Tier IV)
No. of cylinders:	4
Bore and stroke:	94 mm x 120 mm
Displacement:	3.331 L
Rated power output:	NET 74 kW/2,000 min ⁻¹ (ISO 14396: Without fan)
Max. torque:	NET 372 N·m/1,600 min ⁻¹ (ISO 14396: Without fan)



Hydraulic System

Pump	
Type:	Two variable displacement pumps + one gear pump
Max. discharge flow:	2 x 130 L/min, 1 x 20 L/min
Relief valve setting	
Boom, arm and bucket:	34.3 MPa {350 kgf/cm ² }
Travel circuit:	34.3 MPa {350 kgf/cm ² }
Swing circuit:	28.0 MPa {285 kgf/cm ² }
Control circuit:	5.0 MPa {50 kgf/cm ² }
Pilot control pump:	Gear type
Main control valves:	8-spool
Oil cooler:	Air cooled type



Swing System

Swing motor:	Axial piston motor
Brake:	Hydraulic; locking automatically when the swing control lever is in the neutral position
Parking brake:	Oil disc brake, hydraulic operated automatically
Swing speed:	11.0 min ⁻¹
Tail swing radius:	1,490 mm
Min. front swing radius:	2,000 mm



Attachments

Backhoe bucket and arm combination

Use	Backhoe bucket							Slope finishing bucket	
	Normal digging								
								—	
Bucket capacity	ISO heaped m ³	0.24	0.31	0.38	0.45	0.50	0.57	0.70	0.52
	Struck m ³	0.20	0.23	0.28	0.35	0.38	0.43	0.50	—
Opening width	With side cutter mm	600	700	800	900	1,000	1,100	—	—
	Without side cutter mm	500	600	700	800	900	1,000	1,150	1,800 x 900
No. of bucket teeth		3	3	4	4	5	5	5	—
Bucket weight	kg	280	300	320	360	390	400	400	—
Combinations	2.09 m Short arm	○	○	○	○	○	◎	△	—
	2.38 m Standard arm	○	○	○	○	◎	△	—	△
	2.84 m Long arm	○	○	◎	△	—	—	—	—

◎ Standard ○ Recommended △ Loading only



Travel System

Travel motors:	2 x axial-piston, two-step motors
Travel brakes:	Hydraulic brake per motor
Parking brakes:	Oil disc brake per motor
Travel shoes:	46 each side
Travel speed:	5.6 / 3.4 km/h
Drawbar pulling force:	138 kN {14,100 kgf} (ISO 7464)
Gradeability:	70 % {35}



Cab & Control

Cab	
	All-weather, sound-suppressed steel cab mounted on the silicon-sealed viscous mounts and equipped with a heavy, insulated floor mat.
Control	
	Two hand levers and two foot pedals for travel
	Two hand levers for excavating and swing
	Electric rotary-type engine throttle



Boom, Arm & Bucket

Boom cylinders:	100 mm x 1,092 mm
Arm cylinder:	115 mm x 1,120 mm
Bucket cylinders:	95 mm x 903 mm



Dozer Blade (Optional)

Dozer Blade:	110 mm x 220 mm
Dimension:	2,590 mm (width) x 575 mm (height)
Working range:	510 mm (up) x 575 mm (down)



Refilling Capacities & Lubrications

Fuel tank:	200 L
Cooling system:	13 L
Engine oil:	11.5 L
Travel reduction gear:	2 x 2.1 L
Swing reduction gear:	1.65 L
Hydraulic oil tank:	85.2 L tank oil level 126.7 L hydraulic system



Working Ranges

Range	Unit: m		
	Boom	Arm	4.68 m
a - Max. digging reach	2.09 m	2.38 m	2.84 m
b - Max. digging reach at ground level	8.04	8.34	8.78
c - Max. digging depth	7.89	8.19	8.64
d - Max. digging height	5.23	5.52	5.98
e - Max. dumping clearance	8.92	9.19	9.56
f - Min. dumping clearance	6.47	6.74	7.11
g - Max. vertical wall digging depth	2.90	2.58	2.22
h - Min. swing radius	4.68	4.89	5.44
i - Horizontal digging stroke at ground level	2.07	2.00	2.40
j - Digging depth for 2.4 m (8') flat bottom	3.59	4.21	4.70
Bucket capacity ISO heaped m ³	4.96	5.29	5.79
	0.57	0.50	0.38

Digging Force (ISO 6015)

	Unit: kN		
Arm length	2.09 m	2.38 m	2.84 m
Bucket digging force	90.1 (9,190)		
Arm crowding force	64.4 (6,570)		



Dimensions

Arm length	2.38 m
A Overall length	7,500
B Overall height (to top of boom)	2,730
C Overall width of crawler	2,590
D Overall height (to top of cab)	2,870
E Ground clearance of rear end*	865
F Ground clearance*	445

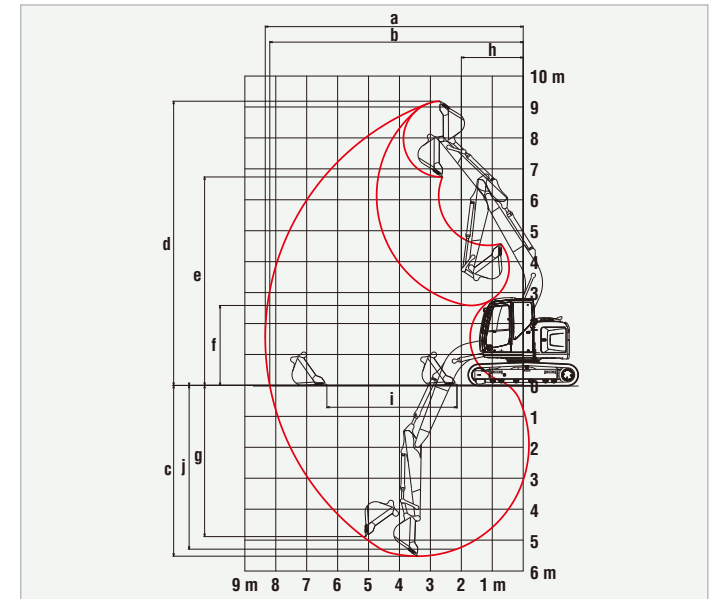

	Unit: mm
G Tail swing radius	1,490
H Tumbler distance	3,040
I Overall length of crawler	3,770
J Track gauge	1,990
K Shoe width	600
L Overall width of upperstructure	2,490

* Without including height of shoe lug.

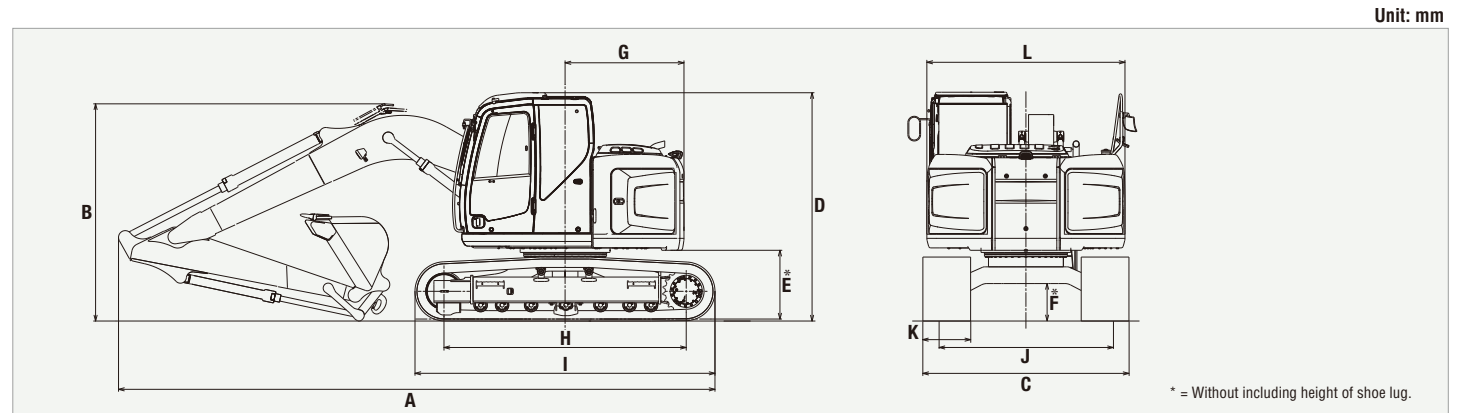

* = Without including height of shoe lug.

Operating Weight & Ground Pressure

In standard trim, with standard boom, 2.38 m arm, and 0.5 m³ ISO heaped bucket

Shaped	Triple grouser shoes (even height)			
	500	600	700	
Shoe width	mm	500	600	700
Overall width of crawler	mm	2,490	2,590	2,690
Ground pressure	kPa	42	36	31
Operating weight	kg	14,100	14,400	14,600
Ground pressure (with Dozer)	kPa	44	38	33
Operating weight (with Dozer)	kg	14,900	15,200	15,400

Two Piece Boom Specification

Working Ranges

Unit: m

Range	Two Piece Boom	
	2.09 m	2.38 m
a- Max. digging reach	8.51	8.80
b- Max. digging reach at ground level	8.36	8.66
c- Max. digging depth	5.42	5.71
d- Max. digging height	9.28	9.54
e- Max. dumping clearance	6.84	7.10
f- Min. dumping clearance	1.19	0.90
g- Max. vertical wall digging depth	4.53	4.86
h- Min. swing radius	2.14	2.04
i- Horizontal digging stroke at ground level	5.18	5.76
j- Digging depth for 2.4 m (8') flat bottom	5.29	5.59
Bucket capacity ISO heaped m ³	0.57	0.50

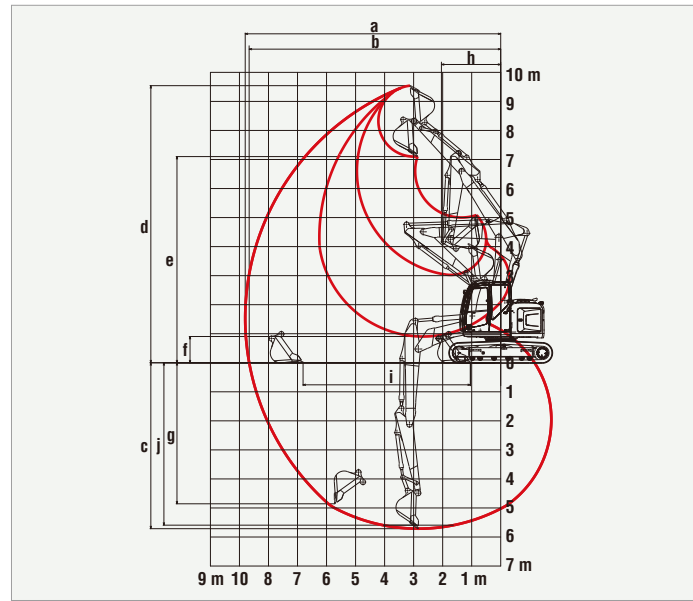

Operating Weight & Ground Pressure

Shape		Triple grouser shoes (even height)		
Shoe width	mm	500	600	700
Overall width of crawler	mm	2,090	2,380	2,840
Ground pressure	kPa	45	38	33
Operating weight	kg	15,100	15,300	15,500

Offset Boom Specification

Working Ranges

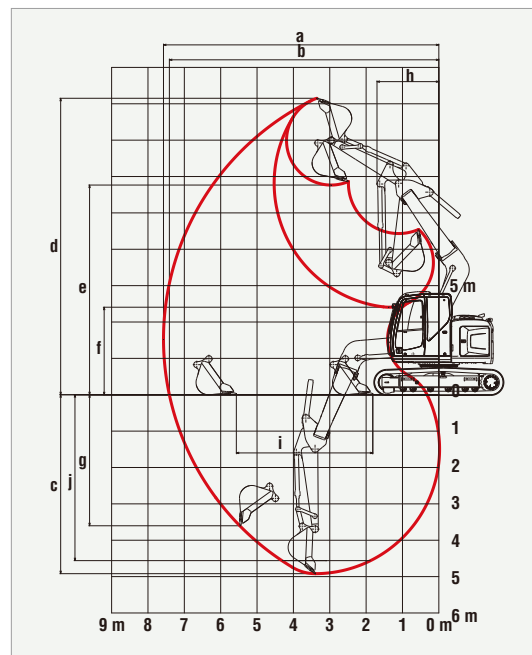

Range	Arm	Offset Boom Specification					
		2.20 m			2.50 m		
		Max. Left	Center	Max. Right	Max. Left	Center	Max. Right
a- Max. digging reach		7.15	7.57	7.14	7.41	7.83	7.40
b- Max. digging reach at ground level		6.98	7.41	6.97	7.25	7.68	7.23
c- Max. digging depth		4.52	4.92	4.50	4.82	5.22	4.80
d- Max. digging height		7.81	8.15	7.80	7.97	8.31	7.96
e- Max. dumping clearance		5.42	5.77	5.41	5.59	5.93	5.57
f- Min. dumping clearance		2.07	2.41	2.05	1.78	2.12	1.77
g- Max. vertical wall digging depth		3.25	3.60	3.23	3.54	3.90	3.68
h- Min. swing radius		1.81	1.72	2.05	1.90	1.79	2.11
i- Horizontal digging stroke at ground level		3.77	3.75	3.77	4.23	4.21	4.23
j- Digging depth for 2.4 m (8') flat bottom		4.16	4.56	4.14	4.48	4.88	4.77
Bucket capacity ISO heaped m ³		0.45			0.38		

Operating Weight & Ground Pressure

Shaped		Triple grouser shoes (even height)		
Shoe width	mm	500	600	700
Overall width of crawler	mm	2,490	2,590	2,690
Ground pressure	kPa	44	37	32
Operating weight	kg	14,700	14,900	15,200

Arm: 2.2 m Bucket: 0.50 m³ *without including height of shoe lug.

Unit: mm

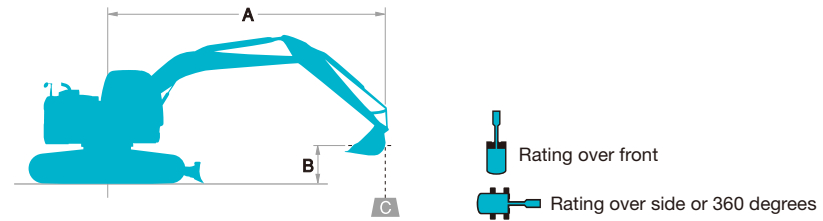
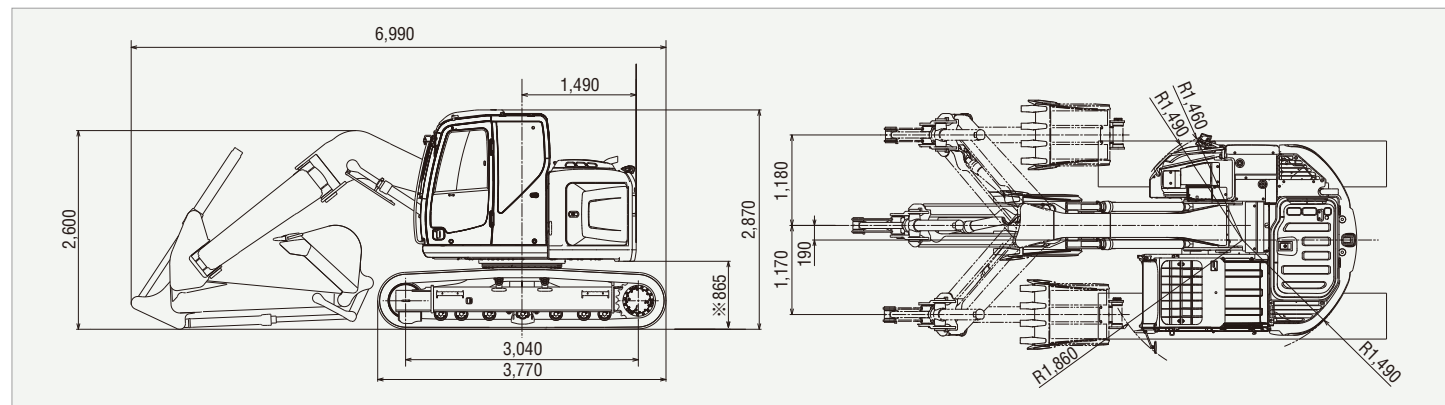

A - Reach from swing centerline for bucket hook
B - Bucket hook height above/below ground
C - Lifting capacities in kilograms
* Max. discharge pressure: 3.43 MPa {350 kgf/cm²}

Mono Boom Specifications

SK140SR _{LC}		Arm: 2.38 m, Bucket 0.5 m ³ ISO heaped 390 kg Shoe: 600 mm										
A	B	1.5 m	3.0 m	4.5 m	6.0 m	At Max. Reach		Radius				
		Rating over front	Rating over side or 360 degrees									
7.5 m	ton					*1.53	*1.53	3.93 m				
6.0 m	ton					*1.23	*1.23	5.64 m				
4.5 m	ton			*2.94	*2.94							
3.0 m	ton			*3.22	*3.22	*2.61	1.95	*1.15	6.58 m			
1.5 m	ton		*5.71	*5.71	*3.96	3.05	3.11	1.86	*1.18	7.08 m		
G.L.	ton		*7.09	4.82	4.56	2.56	2.87	1.64	*1.54	7.06 m		
-1.5 m	ton	*5.24	*5.24	*7.95	4.78	4.47	2.49	2.82	1.60	*2.04	1.41	6.53 m
-3.0 m	ton	*8.11	*8.11	*6.50	4.89	*4.39	2.53			*3.23	1.85	5.54 m
-4.5 m	ton			*3.52	*3.52					*2.75	*2.75	3.72 m

Mono Boom Specifications with Additional Counterweight 585 kg

SK140SR _{LC}		Arm: 2.38 m, Bucket 0.5 m ³ ISO heaped 390 kg Shoe: 600 mm										
A	B	1.5 m	3.0 m	4.5 m	6.0 m	At Max. Reach		Radius				
		Rating over front	Rating over side or 360 degrees									
7.5 m	ton					*1.53	*1.53	3.93 m				
6.0 m	ton					*1.23	*1.23	5.64 m				
4.5 m	ton			*2.94	*2.94							
3.0 m	ton			*3.22	*3.22	*2.61	2.18	*1.15	*1.15	6.58 m		
1.5 m	ton		*5.71	*5.71	*3.96	3.38	*3.24	2.09	*1.18	*1.18	7.08 m	
G.L.	ton		*7.09	5.41	5.02	2.90	3.17	1.87	*1.54	1.44	7.06 m	
-1.5 m	ton	*5.24	*5.24	*7.95	5.38	4.93	2.82	3.13	1.83	*2.04	1.62	6.53 m
-3.0 m	ton	*8.11	*8.11	*6.50	5.48	*4.39	2.86			*3.23	2.11	5.54 m
-4.5 m	ton			*3.52	*3.52					*2.75	*2.75	3.72 m

Mono Boom Specifications

SK140SR _{LC}		Arm: 2.84 m, Bucket 0.38 m ³ ISO heaped 320 kg Shoe: 600 mm											
A	B	1.5 m	3.0 m	4.5 m	6.0 m	7.5 m	At Max. Reach		Radius				
		Rating over front	Rating over side or 360 degrees										
7.5 m	ton				*1.82	*1.82			*1.43	*1.43	4.72 m		
6.0 m	ton				*2.50	*2.50	*1.64	*1.64	*1.18	*1.18	6.21 m		
4.5 m	ton				*2.79	*2.79	*2.66	1.95	*1.11	*1.11	7.08 m		
3.0 m	ton		*4.79	*4.79	*3.53	3.07	*2.96	1.84	*1.27	1.16	*1.12	7.54 m	
1.5 m	ton		*7.26	5.23	*4.45	2.74	2.94	1.69	*1.86	1.11	*1.21	1.05	7.68 m
G.L.	ton		*7.35	4.72	4.50	2.50	2.81	1.57	*1.50	1.06	*1.40	1.05	7.52 m
-1.5 m	ton	*4.48	*4.48	*8.11	4.60	4.36	2.38	2.73	1.51		*1.78	1.17	7.02 m
-3.0 m	ton	*6.99	*6.99	*6.96	4.67	4.37	2.38	2.76	1.53		*2.63	1.49	6.12 m
-4.5 m	ton			*4.58	*4.58	*2.82	2.55				*2.75	2.50	4.55 m

Two Piece Boom Specifications

SK140SR _{LC}		Arm: 2.38 m, Bucket 0.5 m ³ ISO heaped 390 kg Shoe: 500 mm												
A	B	1.5 m	3.0 m	4.5 m	6.0 m	7.5 m	At Max. Reach		Radius					
		Rating over front	Rating over side or 360 degrees											
7.5 m	ton				*2.17	*2.17			*1.36	*1.36	4.98 m			
6.0 m	ton				*3.18	*3.18	*2.07	2.00	*1.19	*1.19	6.41 m			
4.5 m	ton				*3.76	3.33	*2.59	1.94	*1.15	*1.15	7.25 m			
3.0 m	ton	*13.60	*13.60	*6.88	5.71	*4.40	2.96	*2.70	1.79	*1.91	1.12	*1.20	1.05	7.70 m
1.5 m	ton	*6.01	*6.01	*4.15	*4.15	*3.60	2.55	2.88	1.61	1.95	1.05	*1.32	0.95	7.84 m
G.L.	ton	*6.39	*6.39	*4.64	4.21	4.29	2.28	2.71	1.46	1.88	0.98	*1.55	0.94	7.68 m
-1.5 m	ton	*8.12	*8.12	*6.47	4.20	4.17	2.17	2.63	1.38		*1.97	1.03	7.19 m	
-3.0 m	ton	*8.89	*8.89	*4.82	4.31	*3.63	2.19	*2.48	1.40		*2.20	1.30	6.32 m	
-4.5 m	ton	*9.33	*9.33	*4.55	*4.55	*1.99	*1.99				*1.41	*1.41	4.82 m	

Offset Boom Specifications

SK140SR _{LC}		Arm: 2.2 m, Bucket 0.5 m ³ ISO heaped 390 kg Shoe: 500 mm										
A	B	1.5 m	3.0 m	4.5 m	6.0 m	At Max. Reach		Radius				
		Rating over front	Rating over side or 360 degrees									
6.0 m	ton					*1.97	*1.97	4.43 m				
4.5 m	ton					*1.94	*1.94	5.59 m				
3.0 m	ton			*5.24	*5.24	*3.75	2.97	*2.85	1.73	*2.11	1.63	6.17 m
1.5 m	ton		*7.37	4.84	*4.52	2.59	2.83	1.58	*2.50	1.42	6.34 m	
G.L.	ton	*3.86	*3.86	*8.06	4.32	4.31	2.31	2.70	1.46	2.59	1.40	6.14 m
-1.5 m	ton	*5.90	*5.90	*7.57	4.24	4.19	2.21			3.02	1.61	5.52 m
-3.0 m	ton	*8.91	*8.91	*6.06	4.42					*4.20	2.46	4.29 m

Notes:

- Do not attempt to lift or hold any load that is greater than these lift capacities at their specified lift point radius and heights. Weight of all accessories must be deducted from the above lift capacities.
- Lift capacities are based on machine standing on level, firm, and uniform ground. User must make allowance for job conditions such as soft or uneven ground, out of level conditions, side loads, sudden stopping of loads, hazardous conditions, experience of personnel, etc.
- Bucket lift hook is defined as lift point.

- The above lifting capacities are in compliance with SAE J/ISO 10567. They do not exceed 87 % of hydraulic lifting capacity or 75 % of tipping load. Lifting capacities marked with an asterisk (*) are limited by hydraulic capacity rather than tipping load.
- Operator should be fully acquainted with the Operator's and Maintenance Instructions before operating this machine. Rules for safe operation of equipment should be adhered to at all times.
- Lift capacities apply to only machines as originally manufactured and normally equipped by KOBELCO CONSTRUCTION MACHINERY CO., LTD.