



**RT130** | Rough Terrain Crane 130 US ton Lifting Capacity



IMPERIAL

# RT130

ROUGH TERRAIN CRANE

**CONTENTS**

	Page:
<b>Key</b>	
.....	3
<b>Dimensions</b>	
Crane dimensions .....	5
Transport dimensions .....	5
Crane weights .....	6
Steering dimensions .....	7
<b>Load charts</b>	
Range graph main boom .....	8
Load chart main boom .....	9
Load chart pick & carry .....	11
Load chart without counterweight .....	11
Range graph jibs .....	12
Load chart jibs .....	13
<b>Technical description</b>	
Boom .....	14
Winch, rope and hook .....	14, 15
Upper structure .....	15
Cab, controls and safety devices .....	15
Understructure, engine, drive-line and hydraulic .....	16
Vehicle performances .....	16
Tires .....	16
Other optional .....	16

**KEY**

	Counterweight		General performance
	Main boom		Telescoping mode
	Boom length		Boom elevation angle
	Tip height		Working radius
	Boom with extension		Max. boom length with extension
	Main boom with aux head / rooster sheave		Distance from the hook to the head sheave axle
	Slewing / Slewing range allowed		Slewing locked / Slewing locked at specified position
	Slewing brake		Slewing gears
	Outriggers / Lifting on outriggers (100%, 50%, 0% extended)		Lifting on wheels / Pick & Carry
	Crane without counterweight		Crane in standard configuration
	Main winch		Auxiliary winch
	Winch speed		Rope length
	Rope – Standard / Optional		Max. line pull
	Rope diameter		Tires
	Hook block		Gross vehicle weight
	Weight on front axle		Weight on rear axle
	Cab		Controls
	Load limiter / Safety devices		Engine
	Mechanical transmission		Steering
	Hydraulics		Speed
	Working temperature		Heating / Air conditioning
	Gradeability		

HIGHLIGHTS

**RT130**

HIGHLIGHTS

- Rated capacity:  
130 ton @ 10 ft
- Maximum boom length:  
155 ft
- Maximum hook height:  
164 ft



**CRANE DIMENSIONS**

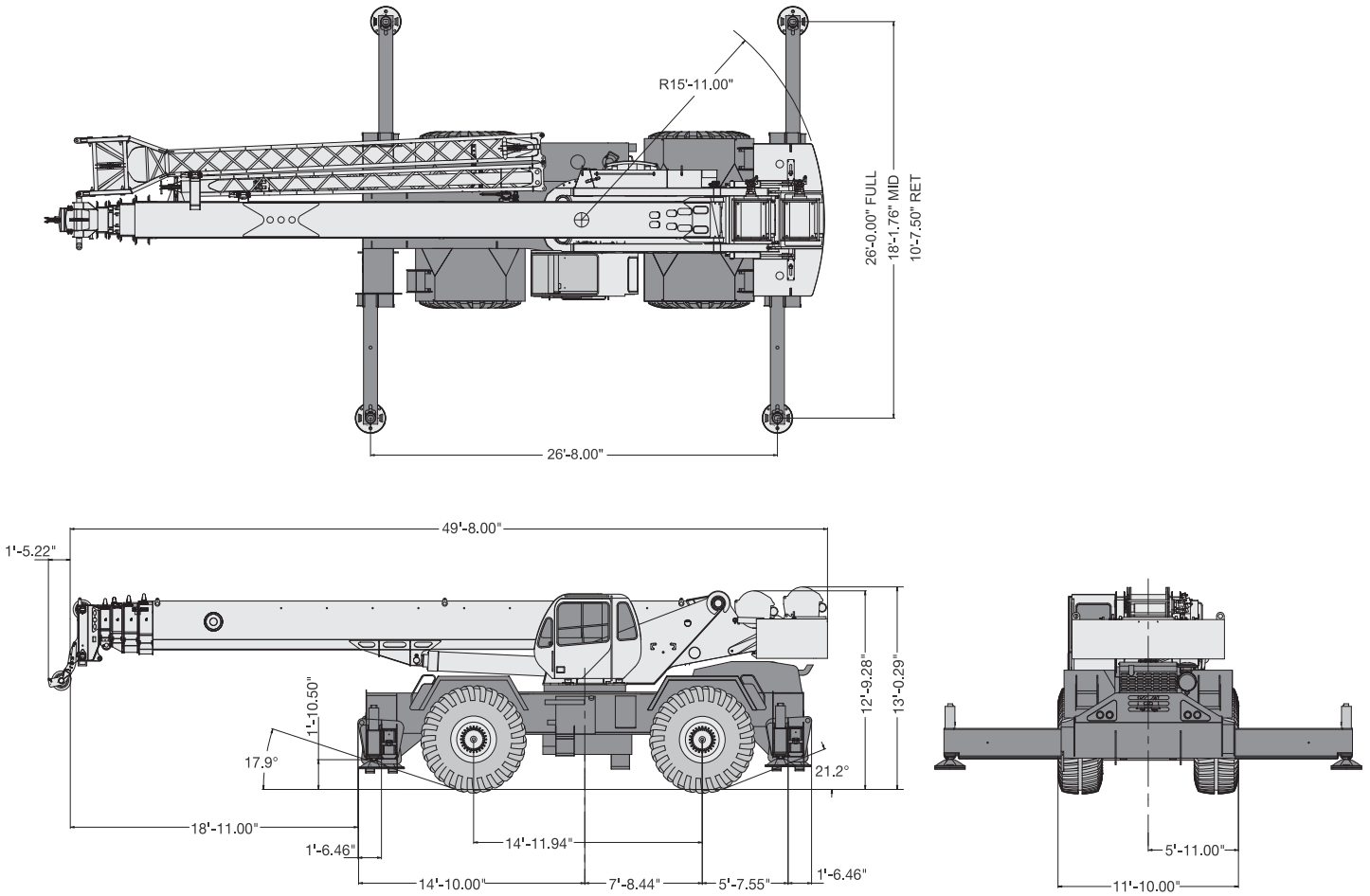



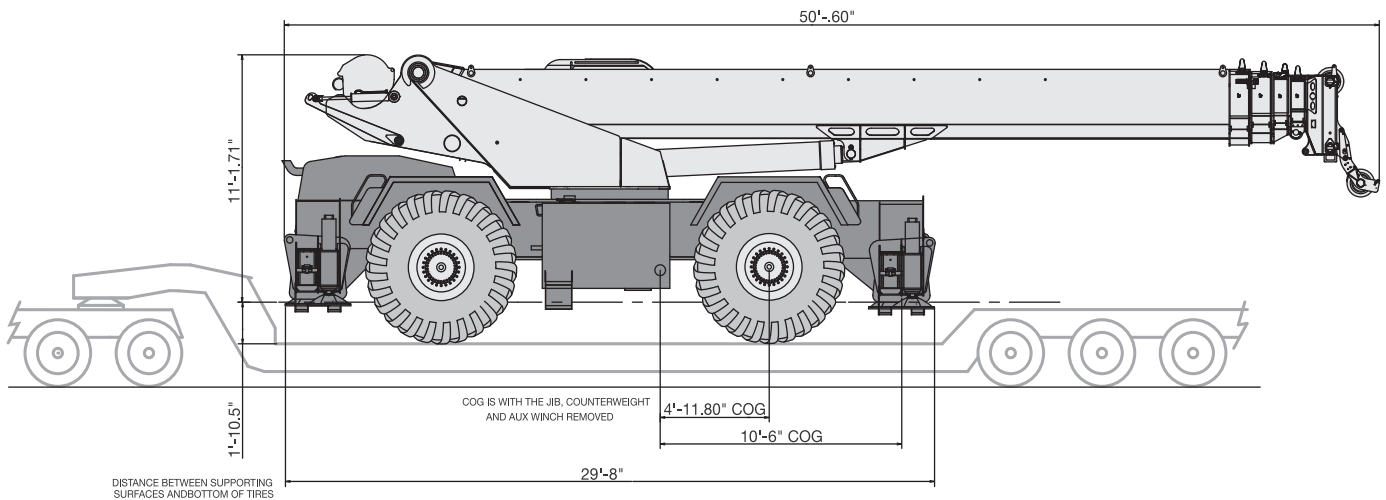





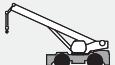



**TRANSPORT DIMENSIONS**



## CRANE WEIGHTS

### WEIGHTS

	↓ GVW	↑	↑
	103672 lb	69136 lb	34536 lb
	133272 lb	57411 lb	75861 lb
<b>Add / Subtract for main crane configuration</b>			
 Stowed aside the boom	+ 4560 lb	+ 7416 lb	- 2856 lb
	+ 130 lb	+ 358 lb	- 228 lb
 Optional	221 lb	-50 lb	+ 2711 lb
 2 With standard rope	+ 659 lb	- 253 lb	+ 912 lb
 2 With optional rope	221 lb	- 97 lb	+ 318 lb
 8 sheaves, 130 ton hanging down from boom head	+ 2550 lb	+ 4293 lb	- 1743 lb
 7 sheaves, 130 ton hanging down from boom head	+ 2310 lb	+ 3889 lb	- 1579 lb
 7 sheaves, 100 ton hanging down from boom head	+ 2120 lb	+ 3569 lb	- 1449 lb
 5 sheaves, 75 ton hanging down from boom head	+ 1680 lb	+ 2707 lb	- 1099 lb
 Hook ball, 12 ton (in tool box)	+ 722 lb	+ 749 lb	- 27 lb

Values are subject to 2% variation

For complete list of list adds and subtracts refer to user manual

**STEERING DIMENSIONS**

**TWO WHEEL STEER**

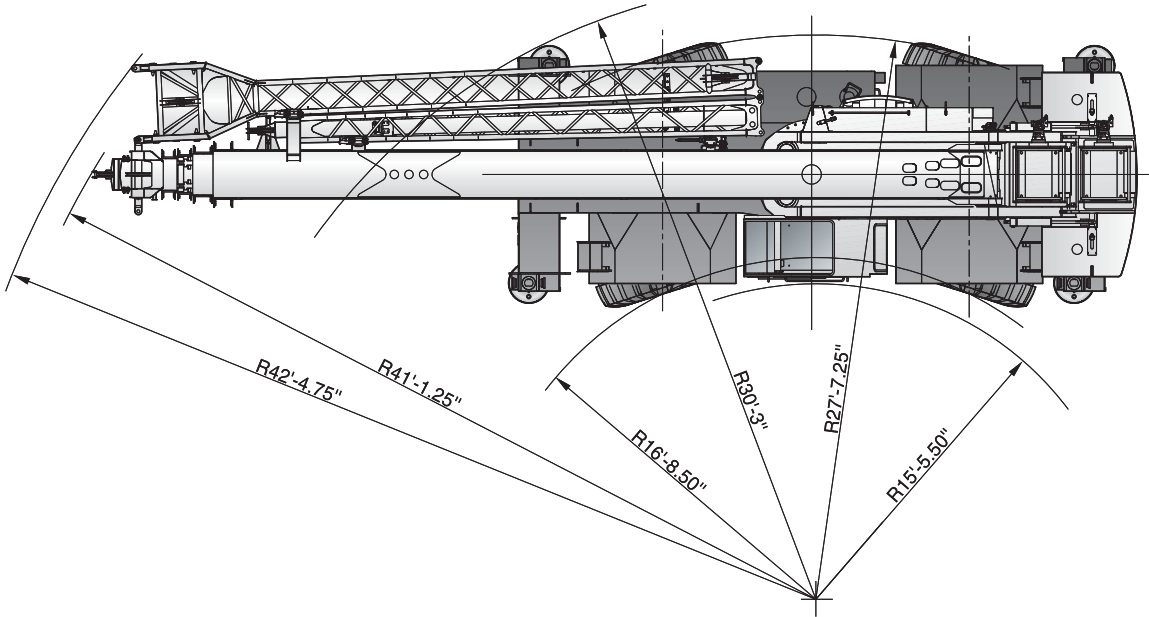

**FOUR WHEEL STEER**

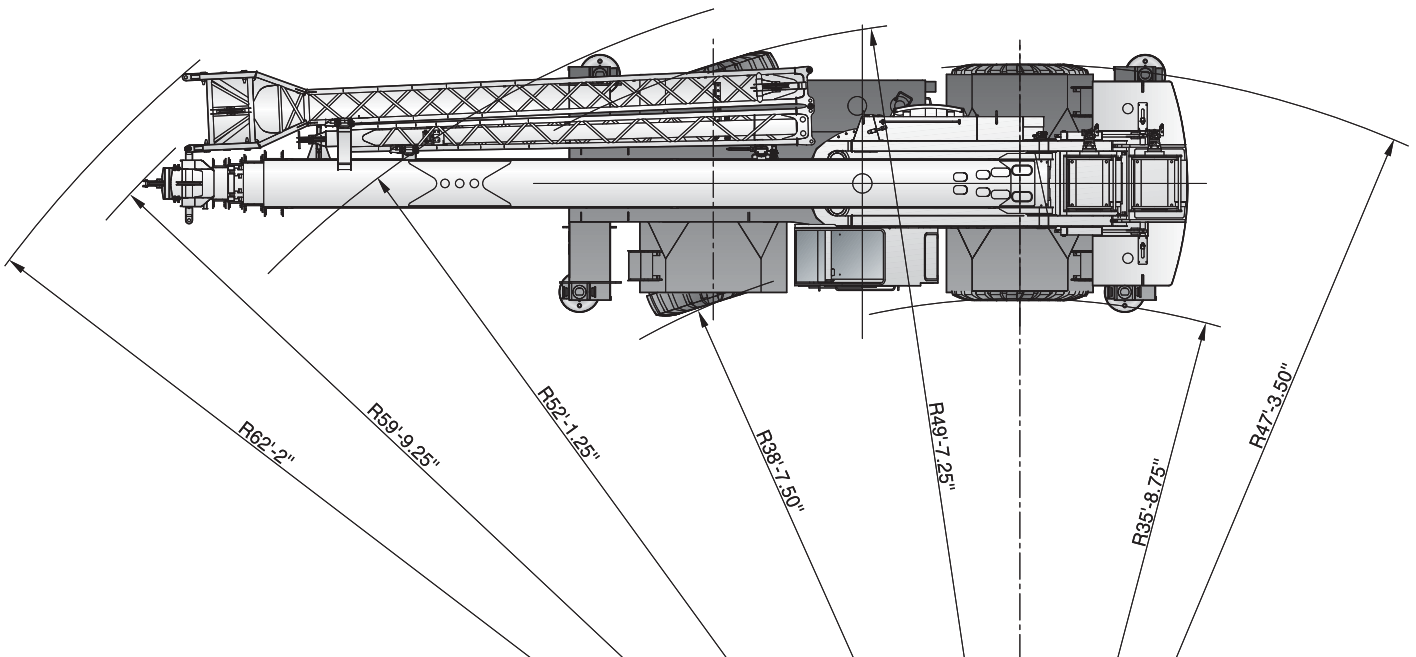



 with hook ball: 7.5 ft  
 with hook block: 10.0 ft

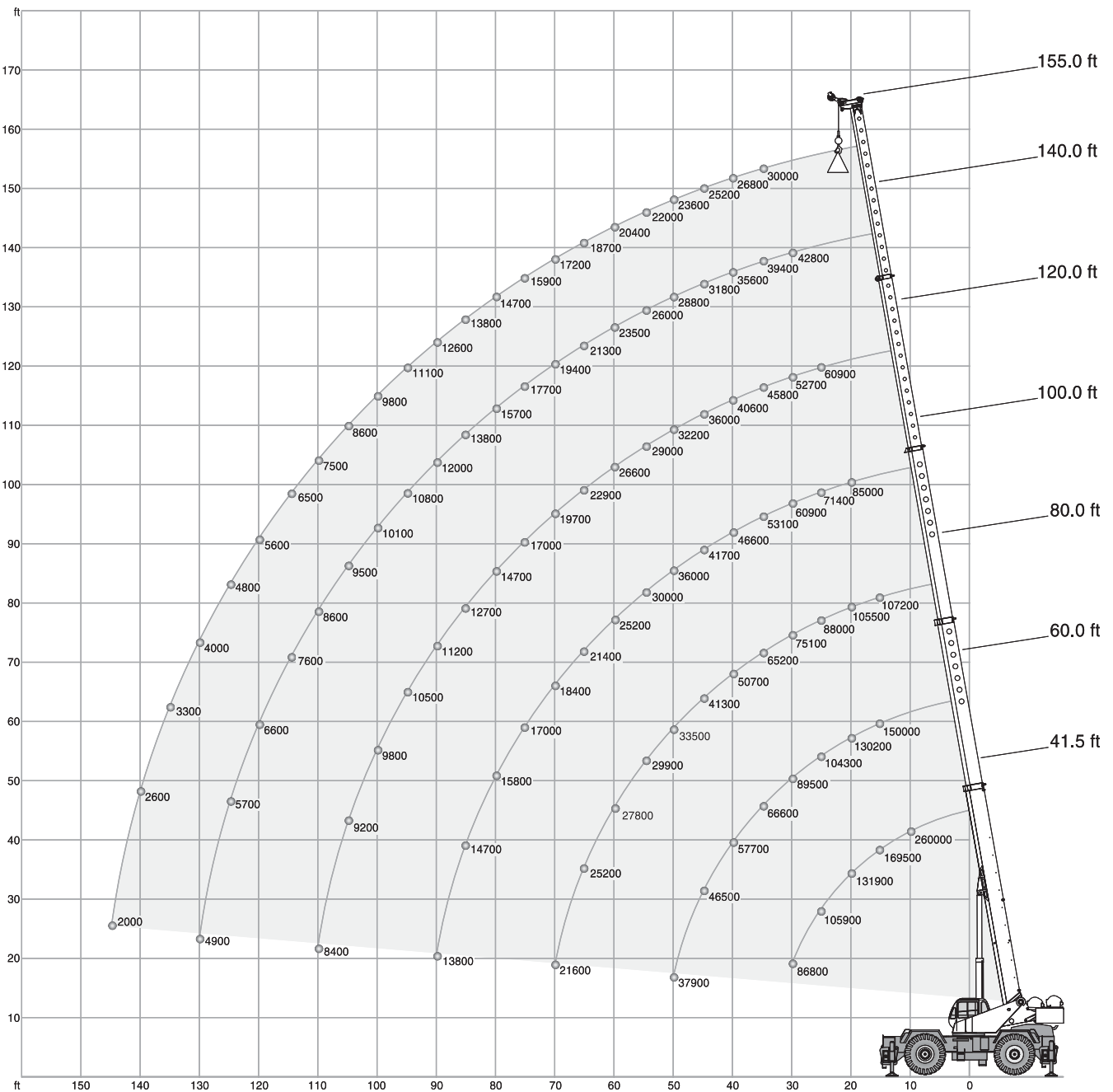





14.8 ton    
 26 ft x 26.7 ft    
 360°    
 AMERICAN STANDARD ASME B30.5

	41.5 ft	60.0 ft	80.0 ft	100.0 ft	120.0 ft	140.0 ft	155.0 ft	
ft								ft
10	260000	-	-	-	-	-	-	10
12	199700	150000	-	-	-	-	-	12
15	169500	150000	107200	-	-	-	-	15
20	131900	130200	105500	85000	-	-	-	20
25	105900	104300	88000	71400	60900	-	-	25
30	86800	89500	75100	60900	52700	42800	-	30
35	-	66600	65200	53100	45800	39400	30000	35
40	-	57700	50700	46600	40600	35600	26800	40
45	-	46500	41300	41700	36000	31800	25200	45
50	-	37900	33500	36000	32200	28800	23600	50
55	-	-	29900	30000	29000	26000	22000	55
60	-	-	27800	25200	26600	23500	20400	60
65	-	-	25200	21400	22900	21300	18700	65
70	-	-	21600	18400	19700	19400	17200	70
75	-	-	-	17000	17000	17700	15900	75
80	-	-	-	15800	14700	15700	14700	80
85	-	-	-	14700	12700	13800	13800	85
90	-	-	-	13800	11200	12000	12600	90
95	-	-	-	-	10500	10800	11100	95
100	-	-	-	-	9800	10100	9800	100
105	-	-	-	-	9200	9500	8600	105
110	-	-	-	-	8400	8600	7500	110
115	-	-	-	-	-	7600	6500	115
120	-	-	-	-	-	6600	5600	120
125	-	-	-	-	-	5700	4800	125
130	-	-	-	-	-	4900	4000	130
135	-	-	-	-	-	-	3300	135
140	-	-	-	-	-	-	2600	140
145	-	-	-	-	-	-	2000	145

**Mode 1** Optimized for best capacities on longer radius

**Mode 2** Optimized for best capacities on short radius

### NOTES TO LIFTING CAPACITY



Lifting capacities do not exceed 85% of tipping load.



Weight of hook blocks and slings is part of the load, and is to be deducted from the capacity ratings.

Consult operation manual for further details.

**Note:** Data published herein is intended as a guide only and shall not be construed to warrant applicability for lifting purposes. Crane operation is subject to the computer charts and operation manual both supplied with the crane.



 14.8 ton    
  9.1 ft x 26.7 ft    
  360°    
 AMERICAN STANDARD ASME B30.5

			41.5 ft	60.0 ft	80.0 ft	100.0 ft	120.0 ft	140.0 ft	155.0 ft	
ft										ft
10			212700	-	-	-	-	-	-	10
12			186000	150000	-	-	-	-	-	12
15			155100	150000	107200	-	-	-	-	15
20			108100	103800	105100	85000	-	-	-	20
25			69600	73600	67200	70200	60900	-	-	25
30			48600	53100	51600	49900	51700	42800	-	30
35			-	40500	42300	37500	39100	39400	30000	35
40			-	31800	33700	31900	30600	31800	26800	40
45			-	25300	27500	28500	24500	25600	25200	45
50			-	20200	22800	23800	21500	22000	21900	50
55			-	-	19000	20100	19400	19600	18300	55
60			-	-	15800	17100	16800	16600	15300	60
65			-	-	13200	14600	14300	14200	12900	65
70			-	-	11000	12500	12300	12100	10900	70
75			-	-	-	10700	10500	10400	9200	75
80			-	-	-	9100	9000	8900	7700	80
85			-	-	-	7600	7700	7600	6400	85
90			-	-	-	6300	6500	6400	5300	90
95			-	-	-	-	5400	5400	4200	95
100			-	-	-	-	4400	4500	3400	100
105			-	-	-	-	3500	3700	2600	105
110			-	-	-	-	2700	2900	-	110
115			-	-	-	-	-	-	-	115
120			-	-	-	-	-	-	-	120
125			-	-	-	-	-	-	-	125
130			-	-	-	-	-	-	-	130
135			-	-	-	-	-	-	-	135
140			-	-	-	-	-	-	-	140
145			-	-	-	-	-	-	-	145

**Mode 1** Optimized for best capacities on longer radius

**Mode 2** Optimized for best capacities on short radius

## NOTES TO LIFTING CAPACITY

Lifting capacities do not exceed 85% of tipping load.

Weight of hook blocks and slings is part of the load, and is to be deducted from the capacity ratings.

Consult operation manual for further details.

**Note:** Data published herein is intended as a guide only and shall not be construed to warrant applicability for lifting purposes. Crane operation is subject to the computer charts and operation manual both supplied with the crane.



14.8 ton
 
 0°
 
AMERICAN STANDARD ASME B30.5

ft	(mph)			ft
	0	creep	2.5	
20	76100	57100	47600	41.3
25	57300	42300	34700	41.3
30	45000	32500	26300	41.3
35	23400	23400	23400	60.0
40	20800	20800	19600	60.0
45	18400	18400	15800	60.0
50	16200	16200	12800	60.0
55	14100	14100	12300	80.0
60	12200	12200	10200	80.0
65	10400	10400	8300	80.0
70	8800	8800	6800	80.0



0 ton
 
 360°
 
AMERICAN STANDARD ASME B30.5

ft	41.5 ft	60.0 ft	80.0 ft	100.0 ft	120.0 ft	140.0 ft	155.0 ft	ft
10	214500	-	-	-	-	-	-	10
12	188000	110000	-	-	-	-	-	12
15	156900	110000	77500	-	-	-	-	15
20	120100	99100	67800	53100	-	-	-	20
25	87200	88900	59400	47300	37700	-	-	25
30	55800	61500	51600	41200	34300	33700	30000	30
35	-	44100	45200	36000	30000	30600	26800	35
40	-	33000	35500	31900	26900	27500	25200	40
45	-	25300	27800	28800	24000	24500	21200	45
50	-	19200	22100	23500	21500	22000	16900	50
55	-	-	17800	19100	18700	18600	13600	55
60	-	-	14400	15700	15300	15200	10900	60
65	-	-	11500	13000	12600	12400	8600	65
70	-	-	8900	10700	10300	10200	6800	70
75	-	-	-	8700	8400	8300	5200	75
80	-	-	-	7100	6800	6700	3800	80
85	-	-	-	5500	5400	5300	2600	85
90	-	-	-	4100	4100	4000	1500	90
95	-	-	-	-	3000	3000	-	95
100	-	-	-	-	2000	2000	-	100
105	-	-	-	-	1100	1200	-	105

### NOTES TO LIFTING CAPACITY

Lifting capacities do not exceed 85% of tipping load.

Weight of hook blocks and slings is part of the load, and is to be deducted from the capacity ratings.

Consult operation manual for further details.

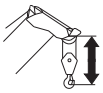

**Note:** Data published herein is intended as a guide only and shall not be construed to warrant applicability for lifting purposes. Crane operation is subject to the computer charts and operation manual both supplied with the crane.

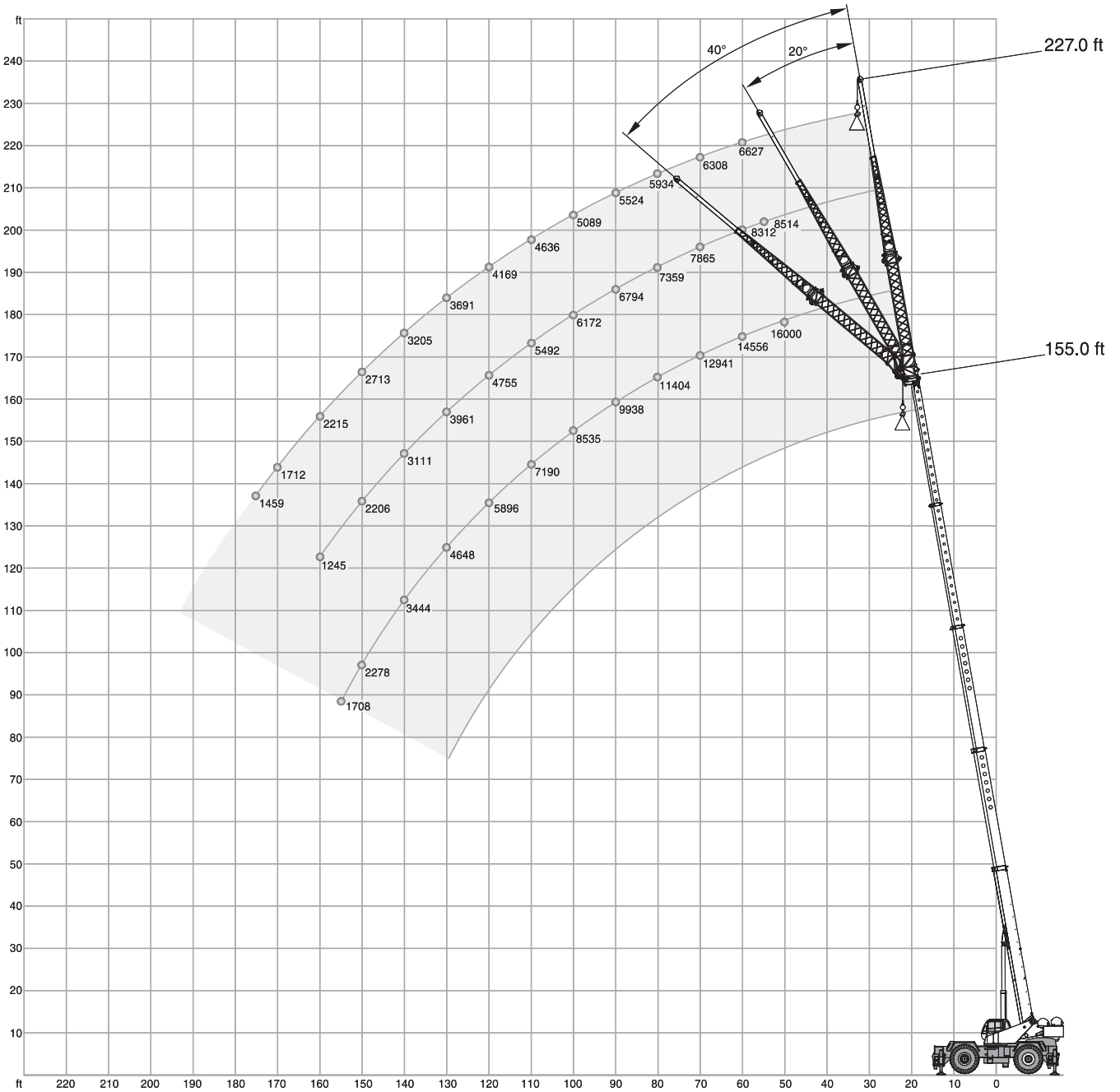

with hook ball: 7.5 ft  
with hook block: 10.0 ft







**14.8 ton**    
 
**26 ft x 26.7 ft**    
 
**360°**    
 AMERICAN STANDARD ASME B30.5

**155 ft**

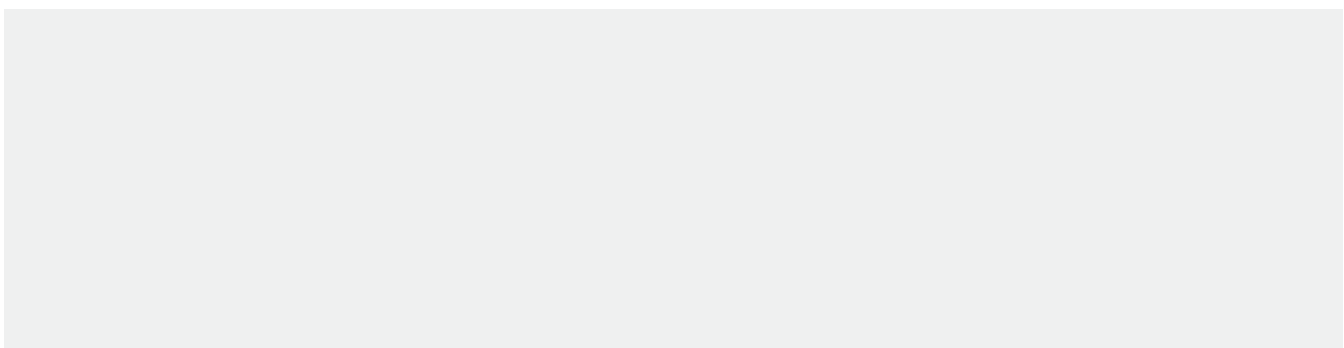
ft	0°	28.8 ft		54.9 ft			72.2 ft			ft
		20°	40°	0°	20°	40°	0°	20°	40°	
50	16000	-	-	-	-	-	-	-	-	50
55	15397	-	-	8514	-	-	-	-	-	55
60	14556	14711	-	8312	-	-	6627	-	-	60
65	13738	13348	12485	8096	-	-	6476	-	-	65
70	12941	12327	11653	7865	-	-	6308	-	-	70
75	12163	11477	10896	7619	6716	-	6126	-	-	75
80	11404	10725	10199	7359	6528	-	5934	-	-	80
85	10663	10033	9551	7084	6318	-	5733	5030	-	85
90	9938	9382	8944	6794	6089	5438	5524	4849	-	90
95	9229	8759	8371	6490	5843	5214	5309	4667	-	95
100	8535	8156	7826	6172	5584	4986	5089	4483	-	100
105	7856	7569	7306	5839	5314	4753	4864	4298	3903	105
110	7190	6994	6807	5492	5033	4516	4636	4113	3731	110
115	6537	6428	6326	5130	4743	4277	4404	3927	3561	115
120	5896	5869	5860	4755	4446	4035	4169	3740	3392	120
125	5267	5316	5409	4365	4142	3790	3931	3552	3225	125
130	4648	4769	4970	3961	3832	3543	3691	3364	3059	130
135	4041	4225	4541	3543	3517	3294	3449	3176	2893	135
140	3444	3685	4122	3111	3197	3044	3205	2987	2729	140
145	2856	3148	-	2665	2873	2792	2960	2797	2566	145
150	2278	2614	-	2206	2545	2538	2713	2608	2403	150
155	1708	2082	-	1732	2214	2284	2464	2418	2241	155
160	-	1551	-	1245	1879	2028	2215	2228	2079	160
165	-	-	-	-	1542	1771	1964	2037	1918	165
170	-	-	-	-	-	-	1712	1846	1757	170
175	-	-	-	-	-	-	1459	1655	1597	175
180	-	-	-	-	-	-	-	1464	1437	180



### NOTES TO LIFTING CAPACITY

Lifting capacities do not exceed 85% of tipping load.

Weight of hook blocks and slings is part of the load, and is to be deducted from the capacity ratings.







Consult operation manual for further details.

**Note:** Data published herein is intended as a guide only and shall not be construed to warrant applicability for lifting purposes. Crane operation is subject to the computer charts and operation manual both supplied with the crane.

## TECHNICAL DESCRIPTION

### BOOM

#### Standard configuration:

	5 sections full power (stability, max. strength)	
	Mode 1: max. stability mode Mode 2: max. strength mode	
	Min. / Max.	41.5 ft / 155 ft
	Lattice type, side stow, bi-fold Pullout extension Angular offsets	28.8 ft / 54.9 ft 17.2 ft 0° / 20° / 40°
	Max. with first jib section swung-on Max. with both jib sections swung-on Max. with both jib sections swung-on and pullout extended	184 ft 210 ft 227 ft
	Max. tip height main boom Max. tip height with first jib section swung-on Max. tip height with first and second jib sections swung-on Max. tip height with both jib sections swung-on and pullout extended	164 ft 193 ft 218 ft 235 ft
	Boom elevation angle range (min. / max.) Boom raising / lowering time Boom extension / retraction time	-3° / +80° 70 s / 100 s 115 s / 106 s
	Single sheave Tip height – boom fully retracted / boom fully extended	54 ft / 165 ft

### WINCH, ROPE AND HOOK





#### Standard configuration:

	Two speeds Grooved drum Storage capacity	1239 ft
	Maximum without load	453 ft / min
	Two speeds Grooved drum Storage capacity	1239 ft
	Maximum without load	453 ft / min
	35 x 7 rotation resistant compacted strand	
		0.75 in
		850 ft
	Min. breaking strength Max. pull line permissible	84000 lb 16800 lb
	Top swivel hook ball with latch 7 metallic sheaves	12 ton 130 ton





**TECHNICAL DESCRIPTION**

		<b>Optional:</b>	
	5 metallic sheaves 7 metallic sheaves 8 metallic sheaves		75 ton 100 ton 130 ton
	Type: XIPS, IWRC, Right Regular Lay		
			0.75 in
			850 ft
	Min. breaking strength Max. pull line permissible		58800 lb 16800 lb

**UPPER STRUCTURE**





		<b>Standard configuration:</b>	
	Weight Pinned to frame and hydraulically mounted / removed		14.8 ton
	Non stop Maximum speed without load		360° 1.5 rpm
	Hydraulic motor Planetary reducer		
	Foot pedal actuated Possibility to set up a partial and constant braking force		

**CAB, CONTROLS AND SAFETY DEVICES**

		<b>Standard configuration:</b>	
	Sliding door on the left side Sliding window on the right side Tilting skylight glass hinged tinted Removable front windshield Six ways adjustable seat		
	Armrest mounted dual axis electro-proportional joysticks Controls for winch and winch rotation indicator, slewing, boom elevation Foot controls for boom telescoping, swing brake and engine throttle Steering wheel column mounted controls for gear shifting Dashboard mounted switches for steering mode, outriggers		
	Electronic load indicator and limiter with graphic interface		
	Hydraulic driven heater and defroster Hydraulic driven heater / AC and defroster LP heater		



## TECHNICAL DESCRIPTION

### UNDERSTRUCTURE, ENGINE, DRIVE-LINE AND HYDRAULIC

		Standard configuration:	
	Hydraulic independent:		
	100 % extended outrigger footprint area		693.3 ft <sup>2</sup>
	50 % extended outrigger footprint area		483.9 ft <sup>2</sup>
	0 % extended outrigger footprint area		283.3 ft <sup>2</sup>
	Floating ground bearings diameters (area)		24 in (452 in <sup>2</sup> )
	Single outrigger jack extending and retracting time		28 s
	Single outrigger beam extending and retracting time		11 s
Access steps to the deck from any side			
	Cummins QSC-300 6 cylinders		
	Rated power		300 HP @ 2200 rpm
	Maximum gross torque		1000 ft-lb @ 1400 rpm
	Intake: turbocharged with intercooler		
	Fuel type		Diesel
	Fuel tank capacity		80 gallons
	6 x 3 powershift with torque converter		
	4WD if traveling in 1 <sup>st</sup> or 2 <sup>nd</sup> gears forward or reverse		
	Rigid mounted front axle		
	Oscillating mounted rear axle		
	Automatic rear axles oscillation lock when superstructure is swung by 10° from centerline in either directions		
	Pneumatic service brakes		
	3 modes hydraulic power steering		
	Front wheels mode – minimum steering curb clearance radius		50.1 ft
	All wheels concentric steering mode – minimum steering curb clearance radius		28.2 ft
	All wheels crab steering mode		
<b>HYDR</b>	Gear pump for main and auxiliary winch		
	Gear pump for boom hoisting and telescoping		
	Gear pump for steering, outriggers and slewing		
	Hydraulic oil tank capacity		304 gallons
	Hydraulic oil filters		60 mesh

		Optional:	
	Cold environment kit		

### VEHICLE PERFORMANCES

		Standard configuration:	
	Max. in 1 <sup>st</sup> gear		145.6 %
	Max. in 6 <sup>th</sup> gear		4.9 %
	Max. (6 <sup>th</sup> gear)		20.4 mph
	Max.		+ 125 °F
	Min.		-20 °F

### TIRES

		Standard configuration:	
	Wide earth moving style thread (E3)		33.25x29-32 PR

### OTHER OPTIONAL

- Revolving amber light (1 light mounted on the cab)
- Yellow strobe light (1 light mounted on the cab – used in place of revolving amber light)
- Work light package (3 lights mounted on the base of the boom, front of the cab, and superstructure)
- 360-degree spotlight
- Tire inflation kit
- Mirror for viewing hoist
- Battery disconnect switch
- Front and/or rear pintle hook







Developed by Global Marketing

**Terex Cranes**

Global Marketing

Dinglerstraße 24

66482 Zweibrücken

Germany

Tel. +49 (0) 6332 830

Email [info.cranes@terex.com](mailto:info.cranes@terex.com)

[www.terex-cranes.com](http://www.terex-cranes.com)

YOUR CONTACT INFORMATION

Effective Date: August 2009. Product specifications and prices are subject to change without notice or obligation. The photographs and/or drawings in this document are for illustrative purposes only. Refer to the appropriate Operator's Manual for instructions on the proper use of this equipment. Failure to follow the appropriate Operator's Manual when using our equipment or to otherwise act irresponsibly may result in serious injury or death. The only warranty applicable to our equipment is the standard written warranty applicable to the particular product and sale and Terex makes no other warranty, express or implied. Products and services listed may be trademarks, service marks or trade-names of Terex Corporation and/or its subsidiaries in the USA and other countries. All rights are reserved. Terex® is a registered trademark of Terex Corporation in the USA and many other countries.